

INSTRUCTION MANUAL FOR  
SAMSON LIQUID RING PUMPS, TYPES:  
KL350, KL430

 ATEX APPROVED



---

# CONTENTS

<b>1</b>	<b>Introduction .....</b>	<b>4</b>
1.1	Declaration of conformity .....	4
1.1.1	Zone 0/1 .....	4
1.1.2	Zone 1/1 .....	5
1.2	Explanation of warning symbols.....	6
1.3	Marking and identification .....	6
1.4	ATEX Directive 2014/34/EU: ATEX Category 1, 2 and 3 pumps only .....	7
1.5	Field of application .....	8
1.6	Disposal .....	8
<b>2</b>	<b>Technical data.....</b>	<b>9</b>
2.1	Dimensions .....	9
2.2	Specifications .....	10
2.3	Power consumption and output.....	11
2.3.1	Vacuum .....	11
2.3.2	Pressure.....	11
2.3.3	Correction factor / cavitation .....	12
2.4	Handling and transport.....	12
2.5	Pump storage.....	13
2.6	Materials .....	14
<b>3</b>	<b>Design of the systems .....</b>	<b>16</b>
3.1	The pump's function.....	16
3.2	System layout example .....	17
3.3	System layout (Zone 0/1).....	18
3.4	System layout (Zone 1/1).....	19
3.5	Liquid separator .....	20
3.6	Cooling system.....	21
3.6.1	KL350 - Vacuum.....	23
3.6.2	KL350 - Pressure .....	24
3.6.3	KL430 - Vacuum.....	25
3.6.4	KL430 - Pressure .....	26
3.7	Pipe system.....	27
3.8	Suction filter .....	27
3.9	Service liquid requirements.....	27

---

<b>4</b>	<b>Installation and start-up.....</b>	<b>28</b>
4.1	Securing the pump .....	28
4.2	Connections to the pump .....	29
4.3	Connecting the service liquid .....	30
4.4	Transmission .....	30
4.5	Earth connection requirements .....	31
4.6	Prior to start-up .....	32
4.7	Direction of rotation .....	32
<b>5</b>	<b>Service, maintenance and inspection intervals .....</b>	<b>33</b>
5.1	Inspection of bearings .....	33
5.2	Inspecting for leakage .....	33
5.3	Draining the liquid separator .....	34
5.4	Check grease cartridges (Category 1 pumps and category 2 pumps with grease cartridges).....	34
5.5	Lubrication of bearings (Category 2 pumps without grease cartridges).....	34
5.6	Inspection of ATEX safety device .....	35
5.7	Inspection and cleaning of service liquid's supply pipe .....	35
5.8	Calibration of ATEX safety device .....	35
5.9	Overhaul of pump.....	35
<b>6</b>	<b>Troubleshooting .....</b>	<b>36</b>

# 1 INTRODUCTION

## 1.1 Declaration of conformity

### 1.1.1 Zone 0/1

SAMSON PUMPS



## Declaration of Conformity

Annex IIA

**Samson Pumps A / S**

Petersmindevej 21  
DK-8800 Viborg

Hereby declares that the following products:

**Liquid ring pump  
KL350, KL430**

Conforms to the following directives:

**Machinery Directive 2006/42/EC**

**ATEX Directive 2014/34/EU** (Applies only to pumps ordered for use in explosive environment)

**Explosion protection as follows on nameplate:**

 II 1G Ex h IIC T4 Ga Internal

 II 2G Ex h IIC T4 Gb External

I hereby declare, that the machine are in conformity with the following harmonized standards:

DS/EN ISO 12100:2011	Safety of machinery - General principles for design - Risk assessment and risk reduction
DS/EN 1012-2 + A1:2009	Compressors and Pumps - Safety requirements - Part 2: Vacuum pumps
DS/EN 1127-1:2011	Explosive atmospheres - Explosion prevention and protection - part 1: Basic concepts and methodology
DS/EN ISO 80079-36:2016	Explosive atmospheres - Part 36: Non-electrical equipment for explosive atmospheres - Basic method and requirements
DS/EN ISO 80079-37:2016	Explosive atmospheres - Part 37: Non-electrical equipment for explosive atmospheres - Non-electrical type of protection constructional safety "c", control of ignition sources "b", liquid immersion "k"

The standard above only applies to the extent that it is relevant for the purpose of the pump. The pump is only declared in accordance with the ATEX Directive in the case where the pump, has been ordered for use in explosive environment. Standard pumps are not in accordance with the ATEX Directive. The product must not be used before the complete system, which it must be incorporated in, has been conformity assessed and found to comply with all relevant health and safety requirements of 2006/42/EC and other relevant directives. The product must be included in the overall risk assessment.

Viborg, 02.03.2017



Kelvin Storm Jensen  
R&D Manager  
Samson Pumps A/S

DOC4029B

Email | [info@samson-pumps.com](mailto:info@samson-pumps.com) | Samson Pumps A/S | Petersmindevej 21  
Web | [www.samson-pumps.com](http://www.samson-pumps.com) | Phone | +45 87 50 95 70 | DK-8800 Viborg

## 1.1.2 Zone 1/1

**SAMSON PUMPS**



### Declaration of Conformity

Annex IIA

#### Samson Pumps A / S

Petersmindevej 21  
DK-8800 Viborg



Hereby declares that the following products:

#### Liquid ring pump KL350, KL430

Conforms to the following directives:

**Machinery Directive 2006/42/EC**  
**ATEX Directive 2014/34/EU**

**Explosion protection as follows:**

 II 2G Ex h T4 Gb X Internal  
 II 2G Ex h T4 Gb X External

I hereby declare, that the pumps are in conformity with the following harmonized standards:

DS/EN ISO 12100:2011	Safety of machinery - General principles for design - Risk assessment and risk reduction
DS/EN 1012-2 + A1:2009	Compressors and Pumps - Safety requirements - Part 2: Vacuum pumps
DS/EN 1127-1:2011	Explosive atmospheres - Explosion prevention and protection - part 1: Basic concepts and methodology
DS/EN ISO 80079-36:2016	Explosive atmospheres - Part 36: Non-electrical equipment for explosive atmospheres - Basic method and requirements
DS/EN ISO 80079-37:2016	Explosive atmospheres - Part 37: Non-electrical equipment for explosive atmospheres - Non-electrical type of protection constructional safety "c", control of ignition sources "b", liquid immersion "k"

The standards above only apply to the extent that it is relevant for the purpose of the pump. The pump is only declared in accordance with the ATEX Directive in the case where the pump, has been ordered for use in explosive environment. Standard pumps are not in accordance with the ATEX Directive. The product must not be used before the complete system, which it must be incorporated in, has been conformity assessed and found to comply with all relevant health and safety requirements of 2006/42/EC and other relevant directives. The product must be included in the overall risk assessment.

Viborg, 02.03.2017

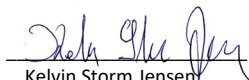
  
Kelvin Storm Jensen  
R&D Manager  
Samson Pumps A/S

DOC4041

Email | [info@samson-pumps.com](mailto:info@samson-pumps.com) | Samson Pumps A/S | Petersmindevej 21  
Web | [www.samson-pumps.com](http://www.samson-pumps.com) | Phone | +45 87 50 95 70 | DK-8800 Viborg

## 1.2 Explanation of warning symbols

Important technical and safety instructions is showed by symbols. If instructions not performed correctly, may lead to personnel injury or incorrect function of the pump.



To be used with all safety instructions that must be followed. A failure to follow the instructions may result in injury and/or incorrect machine operation.



This symbol stands for safety instructions which – if they are not observed – may lead to a risk of explosion. You must therefore always follow these instructions.

## 1.3 Marking and identification

The pump is equipped with an identification plate that is shown below.

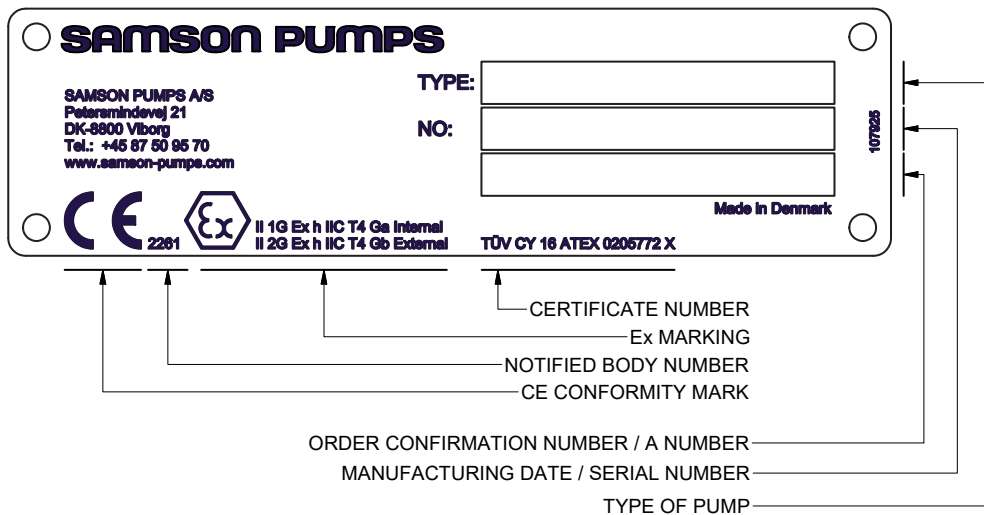

Configuration example:

**KL 350 R 0 S S E 0 0 A X1**

- Type: ←
- Model: ←
- Rotation: ←
- Rotor type: ←
- Pump housing: ←
- Shell: ←
- Flow plates: ←
- Mechanical shaft seals: ←
- Gaskets: ←
- Colour: ←
- Documentation: ←

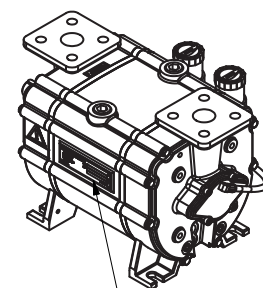

Location of ID plate

DOC107925\_6A

---

## 1.4 ATEX Directive 2014/34/EU: ATEX Category 1, 2 and 3 pumps only

The pump may be incorporated into a larger system, if the internal atmosphere has an area classification of: Zone 0 (for ATEX category 1 pumps) or Zone 1 (for ATEX category 2 pumps)

These systems will be certified in accordance with the ATEX Directive 2014/34/EU: ATEX Category 1, 2 and 3 pumps.

For the certification to be valid, the pump must be installed as described in this manual.

On ATEX Category 1 pumps, you will find an ATEX data plate containing the following information:



II 1G Ex h IIC T4 Ga Internal

II 2G Ex h IIC T4 Gb External

TÜV CY 16 ATEX 0205772 X

On ATEX Category 2 pumps, you will find an ATEX data plate containing the following information:



II 2G Ex h IIC T4 Gb X Internal

II 2G Ex h IIC T4 Gb X External

Explanation of symbols and characters used in ATEX marking:



The European Commission's mark for Ex products

II	Equipment group II (non-mining)
1	Equipment category
G	Type of explosive atmosphere (G = Gas)
Ex	Indication of equipment for use in potentially explosive atmospheres
h	Explosion protection
IIC	Gas group (explosion group)
X	Reference to manual (special conditions for safe use). Applies for both the ATEX marking and certificate number.
T4	Temperature class (T4 = 135°C)
Ga	Equipment protection level

---

## 1.5 Field of application



Inlet of foreign objects, including condensing gases can damage the pump.



The pump is designed exclusively to pump gases, including atmospheric air.



**WARNING!**  
Do not operate the pump so that cavitation can occur! For further information see instruction manual for the Samson Pumps vacuum limiter.

It must be ensured that the inlet gas cannot react with the service liquid and create aggressive bonds that break down the pump's components.

For other operating data, see specifications.

- The pump may only be used with media that are not aggressive to the pump's materials. See section 2.6 for components and appertaining materials.
- When using ATEX-approved pumps, refer to the marking on the pump and the areas of application specified in the ATEX Directive.

## 1.6 Disposal

Samson's liquid ring pump is manufactured so that most of the device can be reused/recycled.

Samson Pumps thus offer users of the company's pumps the option of returning used pumps to be restored or scrapped.

For those who do not wish to take up the factory on this offer, the pump must be taken apart and sorted into its separate components. See section 2.6 for the material of which the pump is made.

These components must be disposed of in accordance with national regulations.



# 2 TECHNICAL DATA

## 2.1 Dimensions

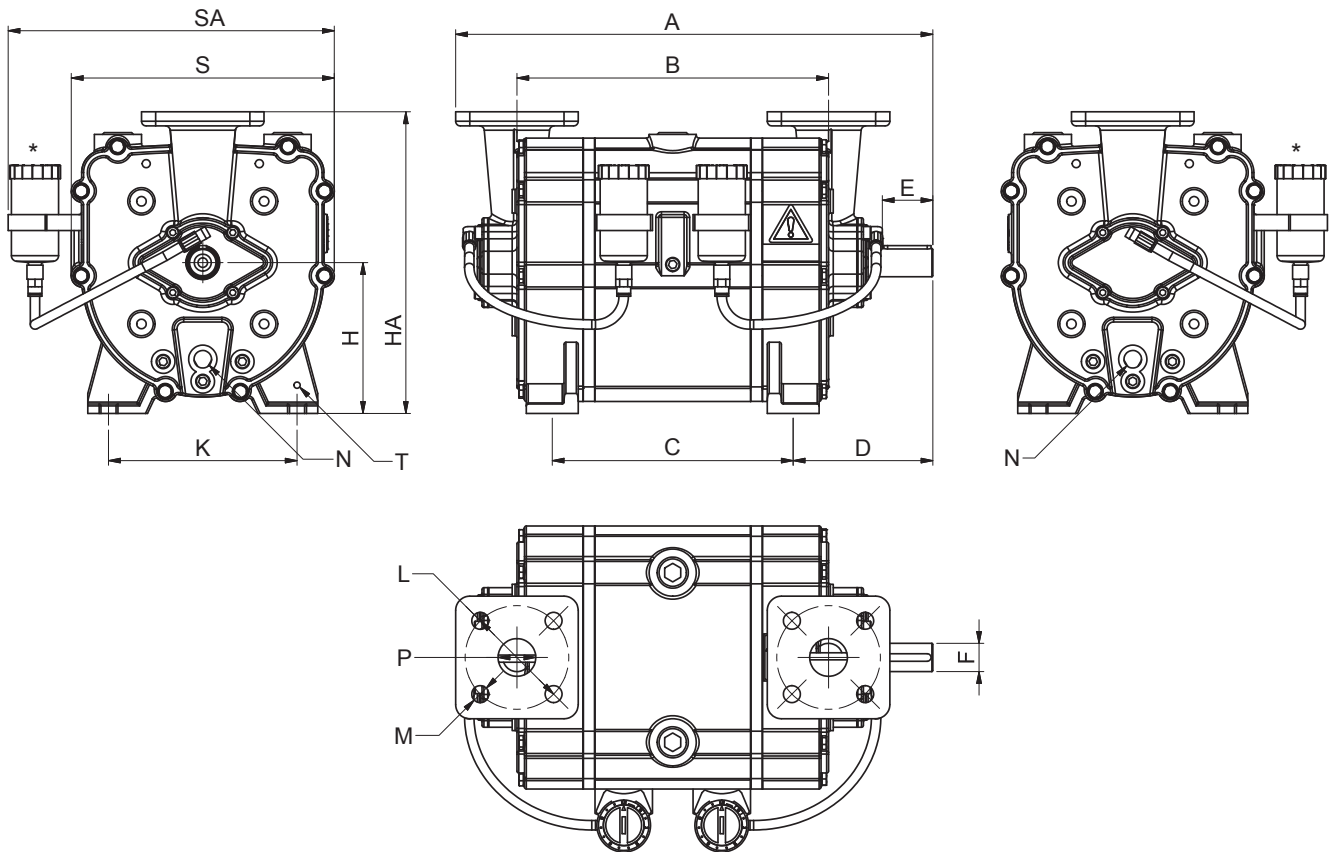

DOC1627289\_1

Dimensions [mm]																	
Pump type	A	B	C	D	E	F	H	HA	K	L	M	N	P	S	SA	T	Weight [kg]
<b>KL350</b>	542	375	305	136,5	60	Ø30/k6	180	350	240	Ø125	Ø18	½"	Ø50	320	385	M8	100
<b>KL430</b>	602	436	366	136,5	60	Ø30/k6	180	350	240	Ø125	Ø18	½"	Ø50	320	385	M8	117

\* -Automatic lubricator: Zone 0/1 - Requirement.  
Zone 1/1 - Optional.

## 2.2 Specifications



A failure to meet these specifications may result in damage to the pump and a potential risk of explosion.

Description		Minimum	Maximum
Ambient temperature, operation		-20°C	40°C
Ambient temperature, storage		-20°C	55°C
Humidity		-	80%
Intake temperature, suction side		-	80°C
Intake temperature, service liquid		-	80°C
Service liquid pipe connection, dimension		1/2"	-
Service liquid pipe connection, length		-	6 m
Noise level		-	70 dB
Maximum radial load on drive shaft	KL350	-	1800 N
	KL430	-	1250 N
Revolutions		1200 rpm	1750 rpm
Pressure		100 mbara	1 barg
Service liquid flow		2 x 3 litres/minute, self-regulating*	-
Lubricating grease	Type of grease	SKF LGWA2	
	Automatic lubrication	SKF LAGD 125/WA2	

\* -It is required to install liquid separator to ensure the pump is supplied as much water as needed. See section 3.3

## 2.3 Power consumption and output

### 2.3.1 Vacuum

#### KL350

	Pressure	[mbara]	100	200	300	400	500	600	700	800
1200 [rpm]	Flow	[m <sup>3</sup> /h]	150	215	232	250	259	264	269	274
	Consumption	[kW]	6.2	8.1	8.9	8.9	8.6	8.1	7.5	6.8
1450 [rpm]	Flow	[m <sup>3</sup> /h]	212	277	300	318	323	326	331	336
	Consumption	[kW]	8.8	10.5	11.4	11.4	11.1	10.6	10	9.3
1750 [rpm]	Flow	[m <sup>3</sup> /h]	275	345	368	380	390	395	397.5	401
	Consumption	[kW]	12	13.7	14.6	14.6	14.2	13.7	13.2	12.5

#### KL430

1200 [rpm]	Flow	[m <sup>3</sup> /h]	65	210	280	315	326	336	345	351
	Consumption	[kW]	8.8	10	11.2	11.8	11.3	10.8	9.8	8.9
1450 [rpm]	Flow	[m <sup>3</sup> /h]	212	329	378	410	425	429	434	437
	Consumption	[kW]	11.7	12.8	14.3	15.2	15.3	14.8	14	13.1
1750 [rpm]	Flow	[m <sup>3</sup> /h]	325	452	480	500	513	523	528	533
	Consumption	[kW]	17.5	18.8	20.1	21	21.1	20.5	19.7	18.8

### 2.3.2 Pressure

#### KL350

	Pressure	[barg]	0.3	0.4	0.5	0.6	0.7	0.8	0.9	1
1200 [rpm]	Flow	[m <sup>3</sup> /h]	270	260	240	220	195	170	135	105
	Consumption	[kW]	8.2	8.8	9.3	9.9	10.5	11	11.6	12.1
1450 [rpm]	Flow	[m <sup>3</sup> /h]	335	330	320	315	305	285	280	265
	Consumption	[kW]	10	10.8	11.4	12.1	12.9	13.5	14.2	15
1750 [rpm]	Flow	[m <sup>3</sup> /h]	411	409	406	403	400	395	385	380
	Consumption	[kW]	16.2	17.1	18	18.9	19.8	20.7	21.6	22.4

#### KL430

1200 [rpm]	Flow	[m <sup>3</sup> /h]	333	330	298	265	220	166	114	70
	Consumption	[kW]	9.8	10.1	10.3	10.8	10.9	11.1	11.4	11.8
1450 [rpm]	Flow	[m <sup>3</sup> /h]	440	435	422	402	370	330	292	255
	Consumption	[kW]	14.9	15.2	15.7	16	16.4	16.9	17.1	17.6
1750 [rpm]	Flow	[m <sup>3</sup> /h]	560	560	559	549	535	522	510	492
	Consumption	[kW]	24.3	25	25.7	26.3	27	27.6	28.2	28.9

The data is based on the following parameters:

- Air temperature 20°C
- Service liquid temperature 15°C
- Test performed with dry air and 1,013 mbar absolute.
- Tolerance ±10%

### 2.3.3 Correction factor / cavitation



Suction pressure and service liquid temperature to be adjusted in such way that cavitation cannot occur!

When the temperature of the service liquid exceeds 15°C, the pump's capacity will be affected with respect to the specified values.

To determine the output at a higher temperature, the correction factor can be used.

Capacity at service liquid temperature higher than 15°C :

$$Q_{>15} = Q_{15} \times K_1$$

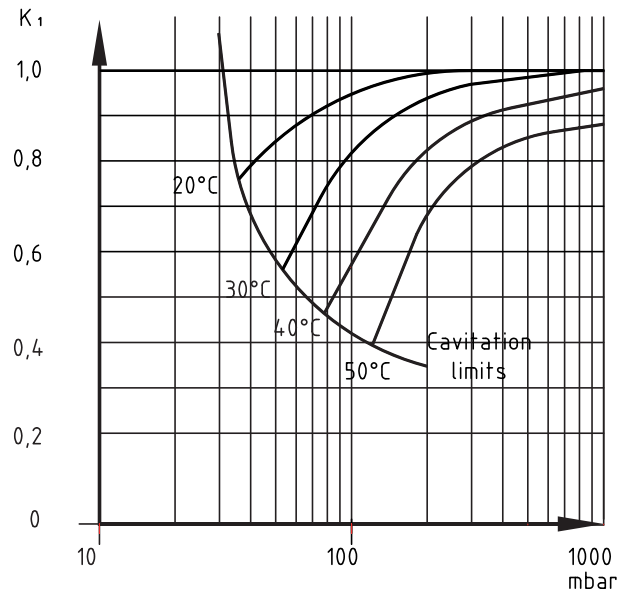

DOC1628005\_1

### 2.4 Handling and transport



The pump may not be used if it is damaged or the identification plate is missing!  
ATEX marking must correspond to the area the pump is operating in!

The pump must be transported in such a way that is not exposed to vibrations and impacts that can overload the bearings.

The pump must be inspected for damages upon delivery. If the pump is damaged, it may not be used and the damage must be reported to the dealer.

Ensure that the pump's identification plate is intact and that the marking of the pump corresponds to its use.

The pump may only be handled using approved lifting eyes, in accordance with nationally applicable regulations and only in a vertical motion.

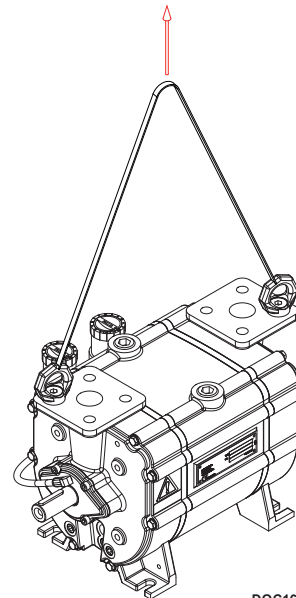

DOC1627236A

The pump can be transported in the following ways:

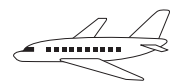
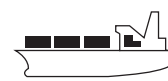

DOC11093A

## 2.5 Pump storage



A failure to comply with the requirements for storing the pump may result in internal damage to the device.



If the temperature is below freezing point of the service liquid it may damage the pump. Under these conditions the pump must be drained completely.



All plugs and protective covers must be fitted during storage.

The pump's service liquid is drained on delivery, and the pump can be immediately stored in accordance with the technical specifications. See specifications.

After operation, the pump can be stored for 30 days without further action.

If the pump remains out of operation for a longer period of time after use, its service liquid must be drained, and the liquid supply to the pump must be shut off.

When emptying the pump, it is important that all compartments inside the pump are emptied.

The pump can be fitted with valves in the draining connections. See below.

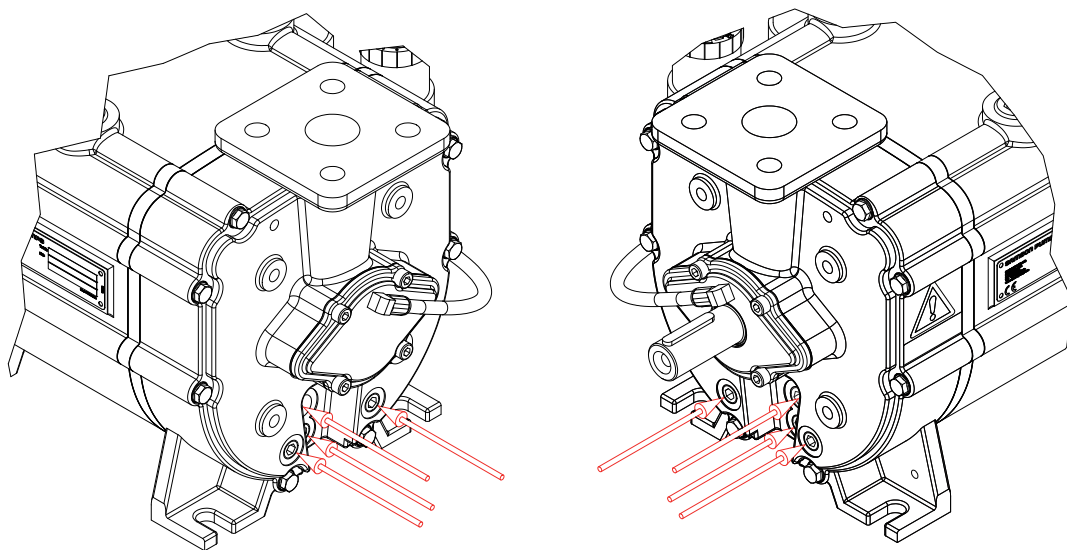

DOC1627287B

## 2.6 Materials

Term	Pos.	Material	Description
Bearing cover	1	Cast iron	EN-GJL-250; EN1561
Radial shaft seal	2	Rubber	Type CB NBR; DIN 3760A
Rubber gasket	3	Rubber	NBR 70
Ball bearing	4	Chrome steel	W.Nr.1.3505
Radial shaft seal	5	Rubber	Type CB NBR; DIN 3760A
Adjustment plate	6	Cast iron	EN-GJL-250; EN1561
Ball guide	7	Polyethylene	PEHD 1000
Valve balls	8	Polypropylene	PPH100NA-20M Anti-static
Spacer for ball guide	9	Stainless steel	W.Nr.1.4401
Flexible tube for automatic lubricator	10	Polyamide	PA6
Push-in nipple	11	Brass	-
Push-in nipple	12	Brass	-
Fitting	13	Brass	-
Clamp for automatic lubricator	14	Polyamide	PA6
Automatic lubricator LAGD 125/WA2	15	Polyamide	PA6
Threaded plug	16	Steel	1.067; DIN 906
O-ring	17	Rubber	NBR 70; DIN 3771
Pump housing	18	Cast iron	EN-GJL-250; EN1561
Paper gasket	19	Paper	Oakenstrong
Mechanical shaft seal	20	NBR / AISI / Carbon	-
Flow plate*	21	Stainless steel	W.Nr.1.4401
		Cast iron	EN-GJL-250; EN1561
Paper gasket	22	Paper	Oakenstrong
Rotor	23	Steel	W.Nr.1.4418 / 1.4404
Shell	24	Cast iron	EN-GJL-250; EN1561
Identification plate	25	Stainless steel	AISI 316

\* -See section 1.3 for configuration of pump.



---

## 3 DESIGN OF THE SYSTEMS

### 3.1 The pump's function

As the name suggests, the pump works with a liquid ring. There is no mechanical contact between the moving parts, and the liquid works like small pistons that, in principle, function as a traditional piston pump.

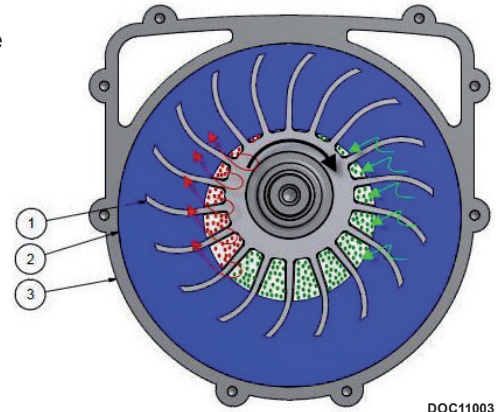

When the pump is started, the liquid ring will rotate at the same speed as the rotor. The rotor is positioned slightly higher than the centre point and divides the liquid ring up into cells. If one were to see the cell in the top position, it would be completely filled with liquid.

As the cell rotates, an air space is created against the hub of the rotor. The liquid moves like a piston away from the hub of the rotor and thereby creates a suction effect. As the cell reaches the bottom, the movement changes direction and causes the service liquid to be pushed in towards the hub of the rotor. The air is thus pushed out of the cell, which becomes completely filled with liquid and ready for a new suction cycle. In order to separate the suction and pressure sides of the pump, the ends of the shell are fitted with a flow plate and pump housing. Some pump types have connections at both ends, while others – known as monoblock pumps – only have a connection on one end of the liquid ring.

A certain volume of the service liquid and gas will flow out of the pump. The pump must therefore be constantly supplied with new service liquid.

In addition to replacing any lost liquid, the new liquid supply will cool the compressor gas in the pump and lubricate the mechanical shaft seals.

The composition and correct addition of service liquid are essential to the functioning of the pump. See section 3 on the liquid composition.



## 3.2 System layout example



- The product does not get sucked into the system, by installing of suitable level transmitter.
- The maximum working pressure does not exceed specifications, by installing a safety valve.

The liquid ring pump can be integrated in a system which takes advantage of both sides of the pump, vacuum and pressure. The example on illustrates the pump installed with a 4-way valve and a product tank. The 4-way valve, depending on position, will fill the tank by vacuum or empty the tank by pressure.

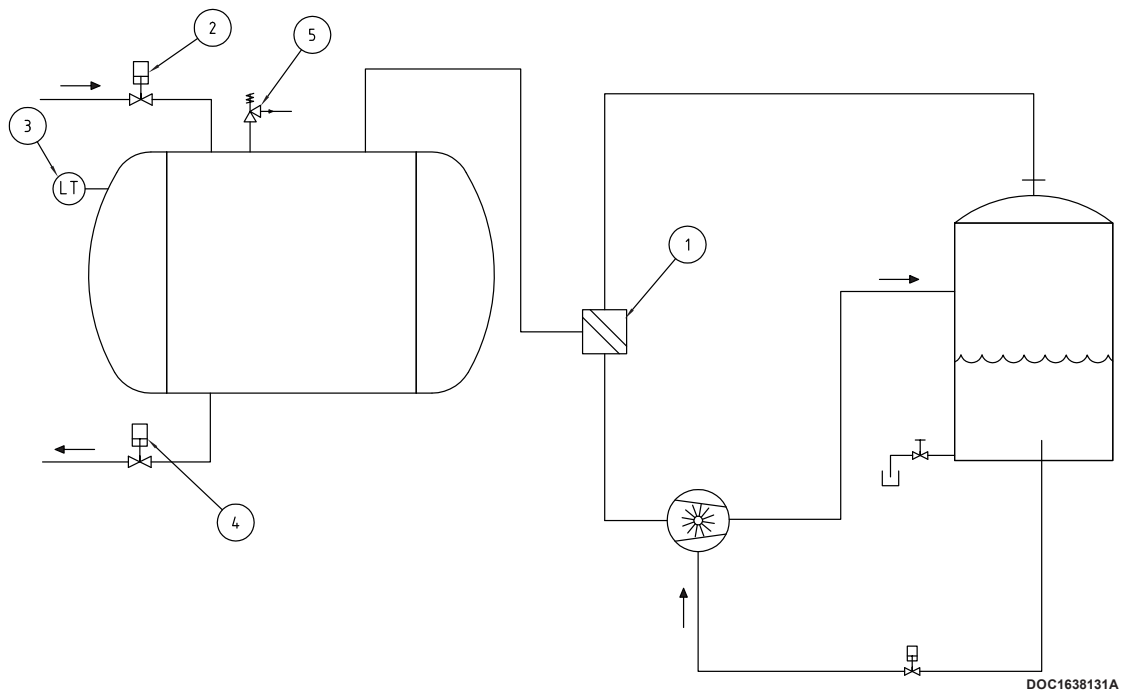

Pos.	Description
1	4-way valve
2	Suction valve
3	Level transmitter
4	Discharge valve
5	Safety valve

### 3.3 System layout (Zone 0/1)



To safeguard the pump so that it can operate in potentially explosive areas, the components used in the safety device must stop the pump in the event of abnormal operation.

The pump can be fitted with the components specified in section 3.3

The service liquid connection that feeds service liquid to the pump must be fitted with flow meters in positions 8 and 9, on both valve inlets.

To prevent the loss of service liquid, stop valves should be installed between the liquid separator and the pump. See Pos. 10 and 11. These valves must be closed when the pump is not in operation. The opening of the valves must be performed automatically when the pump starts.

Max. 1 m after the pump, a temperature sensor must be installed in position 7, which also serves as a safety device and which must stop the pump if the output temperature exceeds the limit.

The liquid level in the liquid separator must be monitored by a level sensor at position 6, which also stops the pump in the event of an insufficient level of liquid.

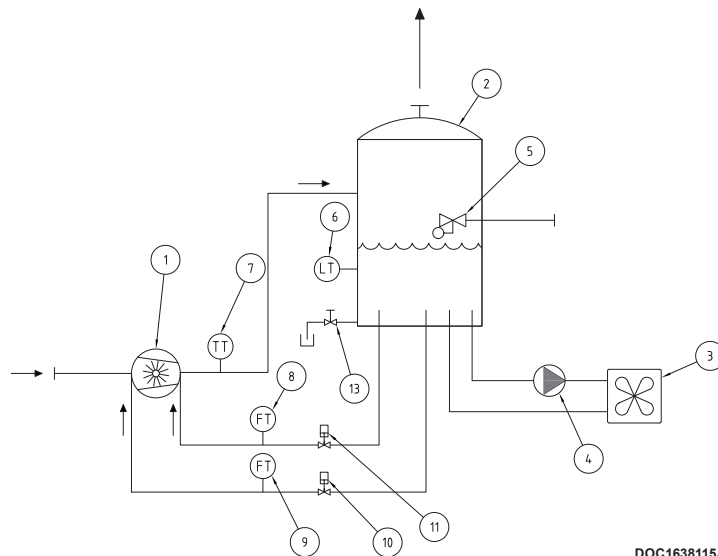

DOC1638115A

Pos.	Description	Set
1	Vacuum pump	-
2	Liquid separator	-
3	Cooler or heat exchanger	-
4	Circulation pump	-
5	Float valve	-
6	Level switch, applies to category 1	Min. 50 L
7	Temperature transmitter, applies to category 1	Max. 80 °C
8	Flow meter, applies to category 1	Min. 3 L/min.
9	Flow meter, applies to category 1	Min. 3 L/min.
10	Stop valve	-
11	Stop valve	-
13	Drain valve	-

### 3.4 System layout (Zone 1/1)



Install an automatic service liquid supply, for example the shown float valve pos 5 – OR provide the liquid separator with an alarm for low level of service liquid pos 17.

Systems in this category can be built as illustrated below:

Use an automatic stop valve pos 10, which opens the service liquid supply to the pump when it starts.

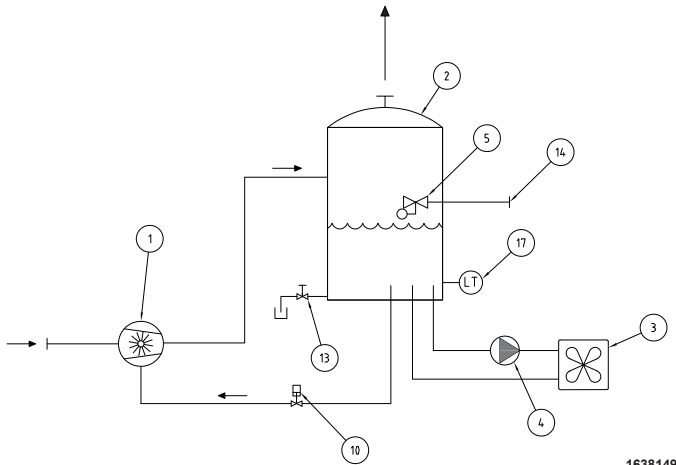

Pos.	Description
1	Vacuum pump
2	Liquid separator
3	Cooler
4	Circulation pump
5	Float valve
10	Stop valve
13	Drain valve
14	Service liquid connection
17	Level transmitter

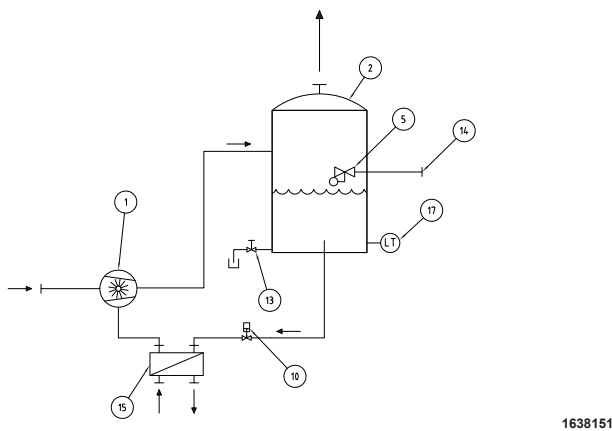

Pos.	Description
1	Vacuum pump
2	Liquid separator
5	Float valve
10	Stop valve
13	Drain valve
14	Service liquid connection
15	Plate heat exchanger
17	Level transmitter

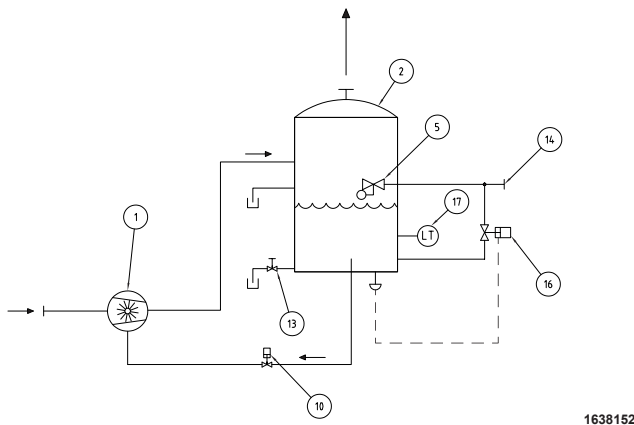

Pos.	Description
1	Vacuum pump
2	Liquid separator
5	Float valve
10	Stop valve
13	Drain valve
14	Service liquid connection
16	Thermostatic valve
17	Level transmitter

---

### 3.5 Liquid separator



Liquid separator is mounted in such way that the minimum level of service liquid is minimum 0,5 m above the pump's shaft.



When operating the drain valves, the outlet may contain explosive gases, corresponding to the classification of the pump's suction side.

To prevent calcium deposits, use a liquid separator or take necessary measures to prevent calcium in the service liquid.

The liquid separator is located in immediate proximity to the pump, so that the length of the outlet pipe from the pump is minimised. Due to potential pressure loss, the length may not exceed 2 metres. The level of liquid in the liquid separator is recommended to be kept at 1-1.5 metres above the pump's shaft. This ensures the correct influx pressure and the correct flow of service liquid.

The liquid supply between the liquid separator and pump must be implemented with a permanent pipe connection with a dimension and length specified in specifications.

It may be advantageous to fit the liquid separator with a float valve which automatically supplies liquid and maintains a constant level.

The liquid separator can be fitted with a drain valve at the lowest place in the tank. The valve can be operated when the separator needs to be drained to remove contaminants.

### 3.6 Cooling system

The compression in the pump generates heat, which will cause the temperature of the service liquid to rise. This means that it will often be necessary to cool the liquid. This can be done using an air cooler or heat exchanger. For short-term operation with intermittent breaks, natural cooling may be sufficient.

Depending on the temperature, the suctioned gas may be sufficient for cooling purposes, though it may also lead to an increased need for cooling.

The necessary cooling requirement can be found in chapters 3.6.1 to 3.6.4

Delta T ( $\Delta t$ ) is the temperature difference between the suctioned gas ( $T_1$ ) and the maximum acceptable service liquid temperature ( $T_2$ ). See below.

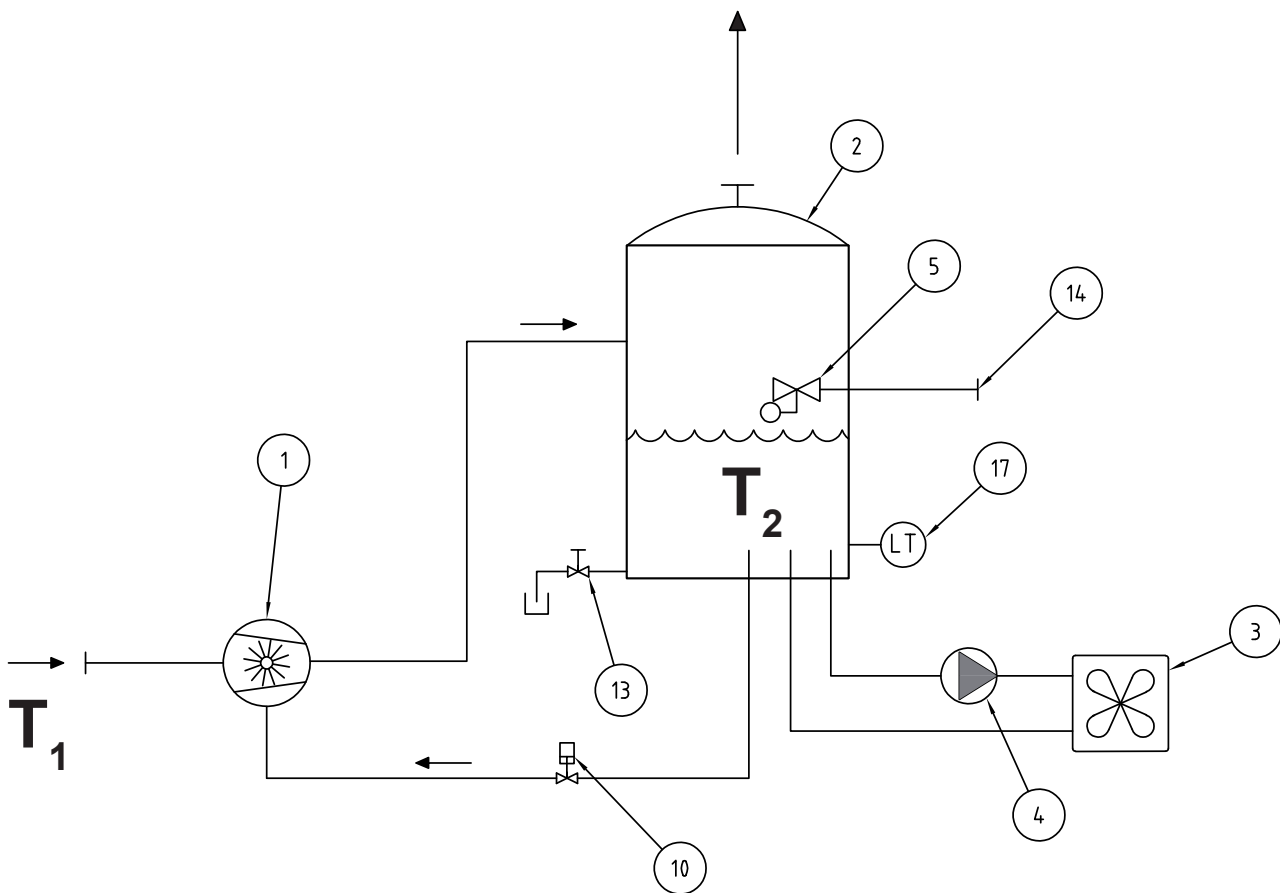

1638149

Pos.	Description
1	Vacuum pump
2	Liquid separator
3	Cooler
4	Circulation pump
5	Float valve
10	Stop valve
13	Drain valve
14	Service liquid connection
17	Level transmitter

**Example 1:** The intake temperature is 5°C, and the desired maximum service liquid temperature is 45°C.

$$\Delta t = 5 - 45 = -40^\circ\text{C}.$$

The cooling requirement at a pressure of 550 mbara will be 3 kW. See below.

**Example 2:** The intake temperature is 60°C, and the desired maximum service liquid temperature is 30°C.

$$\Delta t = 60 - 30 = 30^\circ\text{C}.$$

The cooling requirement at a pressure of 700 mbara will be 4.8 kW. See below.

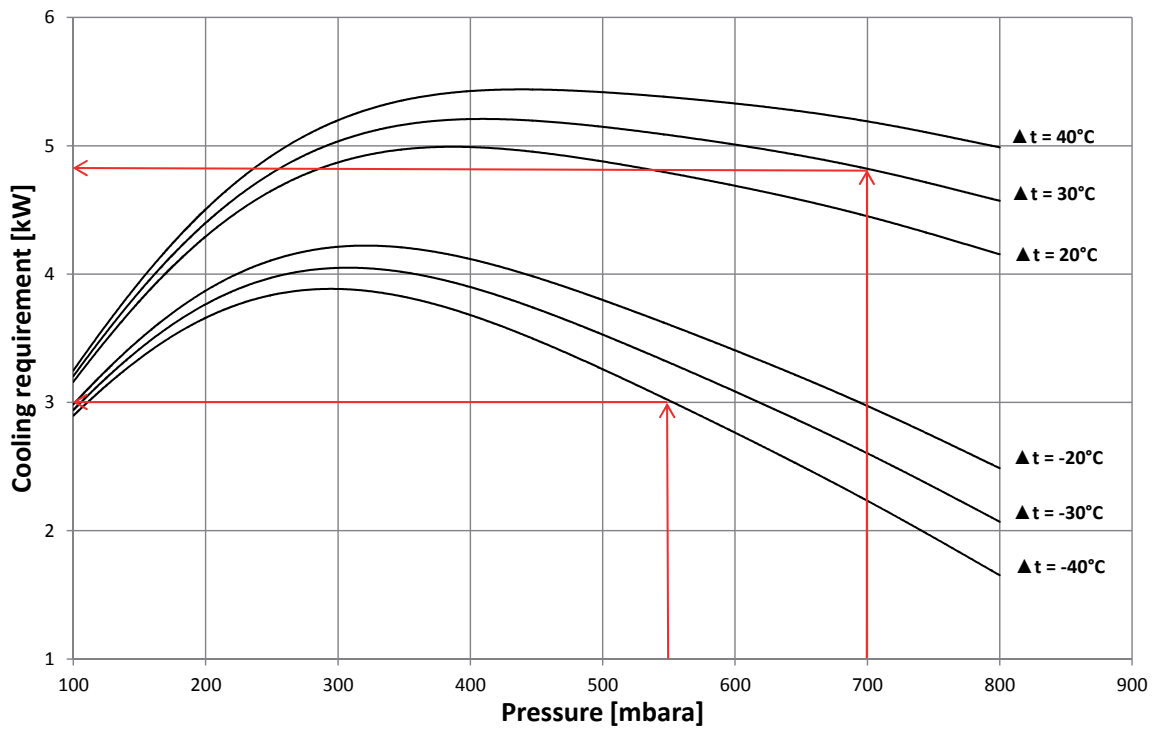

### 3.6.1 KL350 - Vacuum

KL350 - 1200 rpm - Vacuum

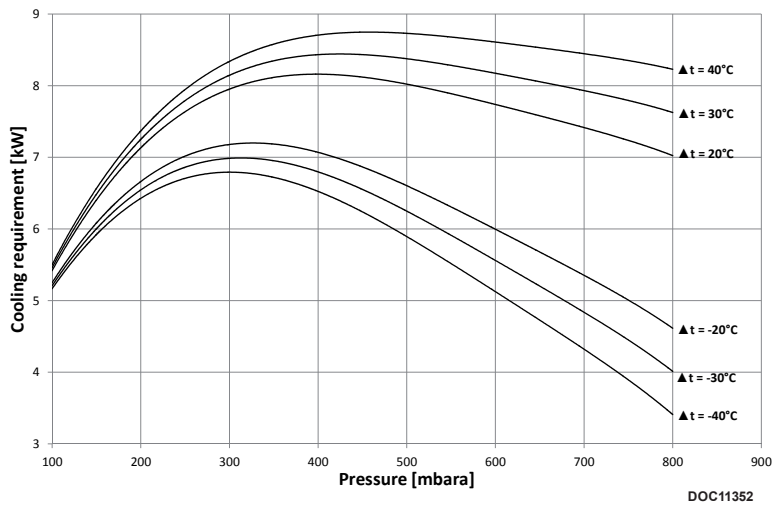

KL350 - 1450 rpm - Vacuum

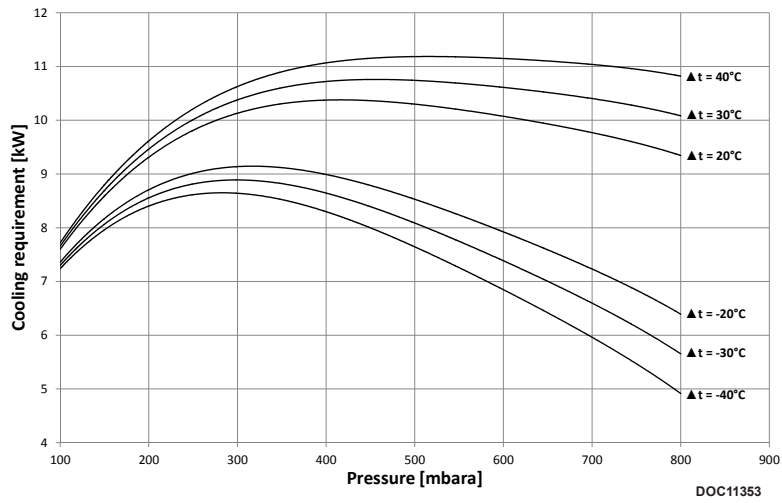

KL350 - 1750 rpm - Vacuum

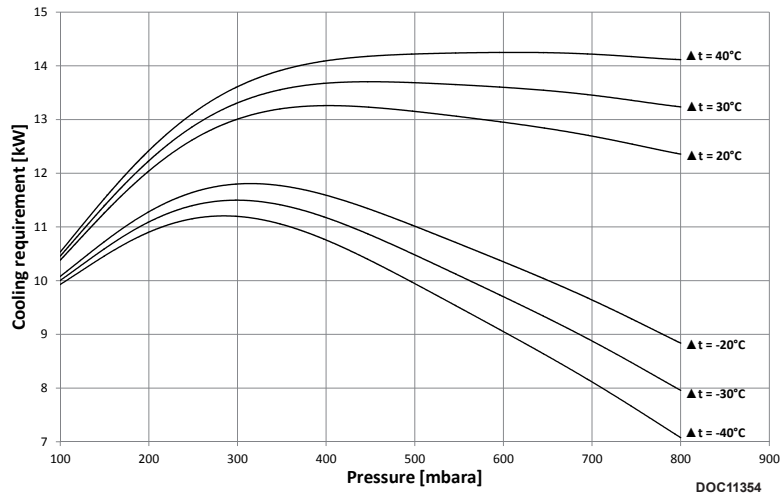

### 3.6.2 KL350 - Pressure

#### KL350 - 1200 rpm - Pressure

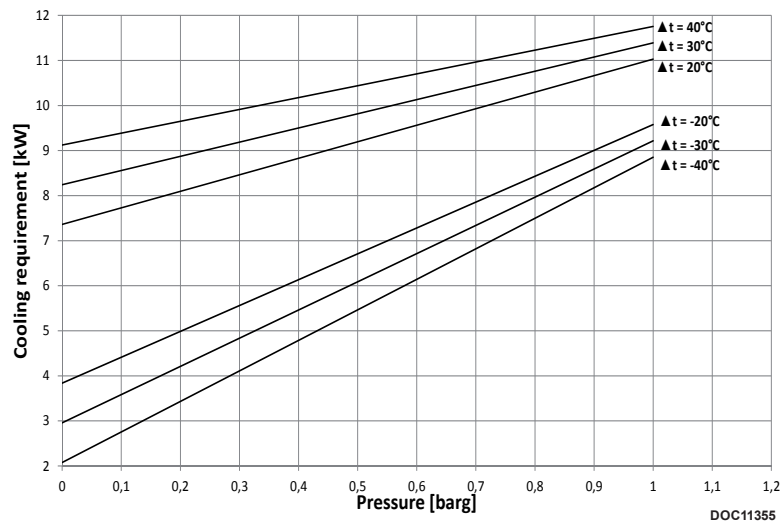

#### KL350 - 1450 rpm - Pressure

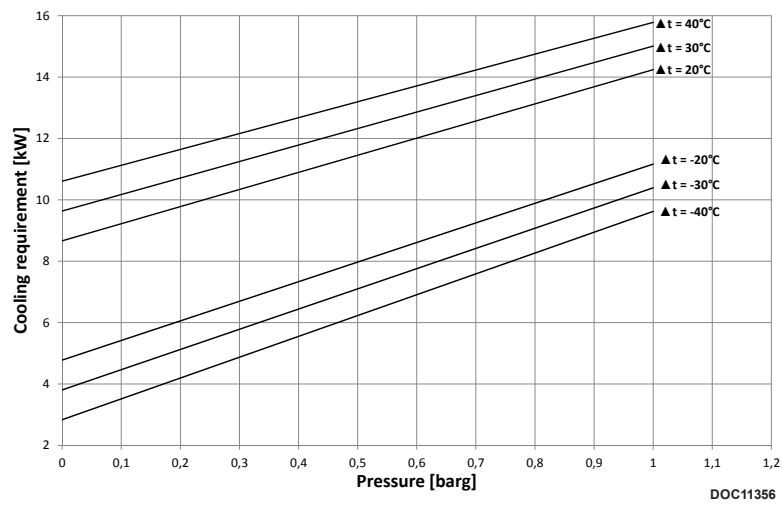

#### KL350 - 1750 rpm - Pressure

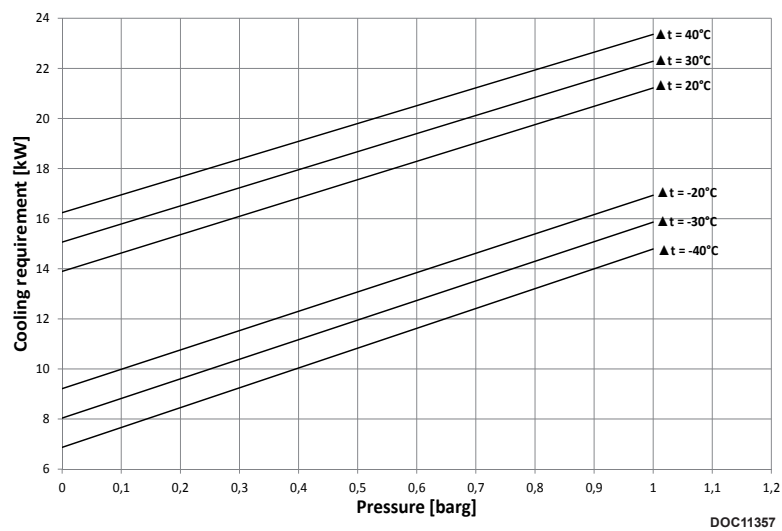



### 3.6.3 KL430 - Vacuum

KL430 - 1200 rpm - Vacuum

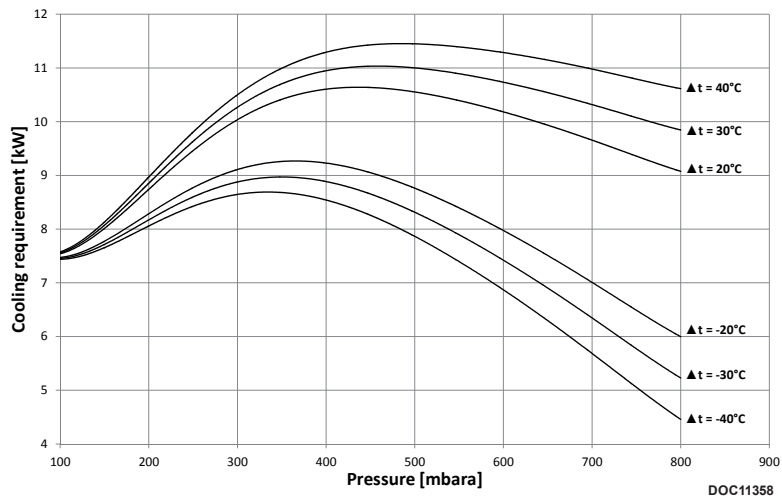

KL430 - 1450 rpm - Vacuum

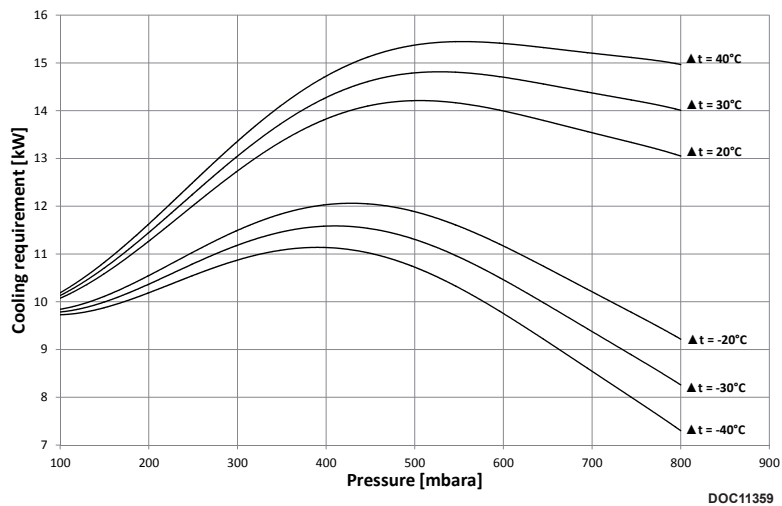

KL430 - 1750 rpm - Vacuum

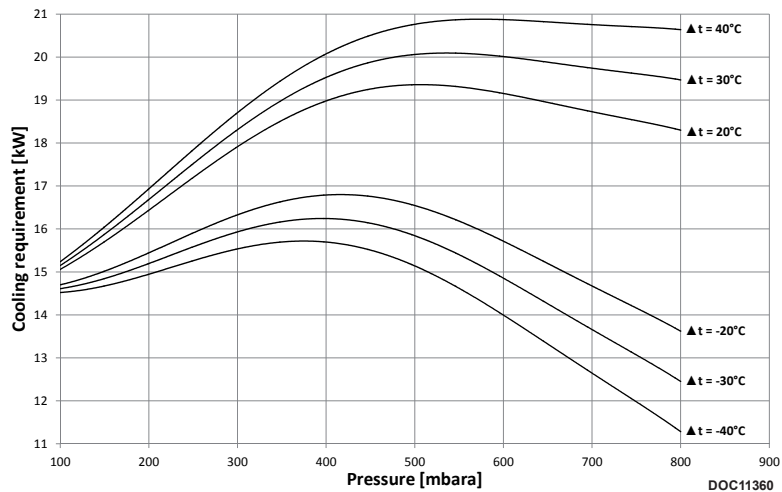

### 3.6.4 KL430 - Pressure

KL430 - 1200 rpm - Pressure

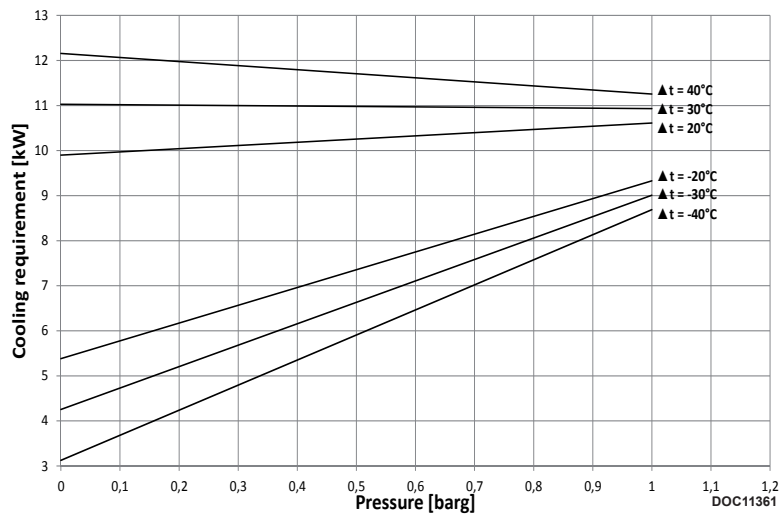

KL430 - 1450 rpm - Pressure

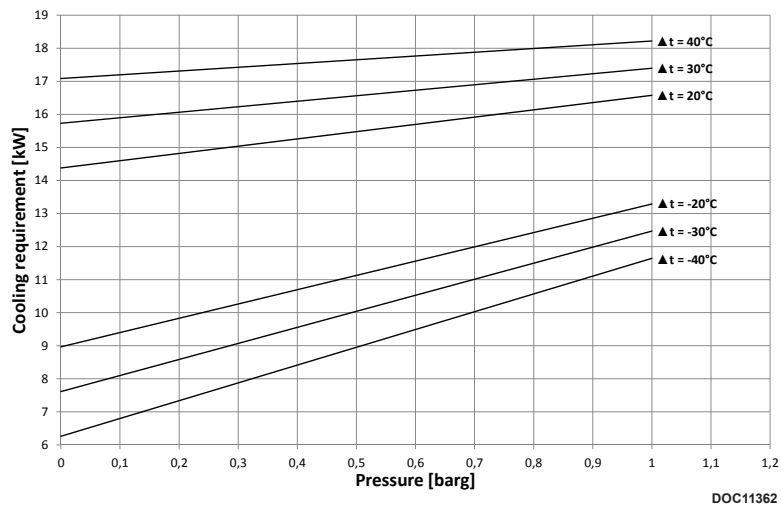

KL430 - 1750 rpm - Pressure

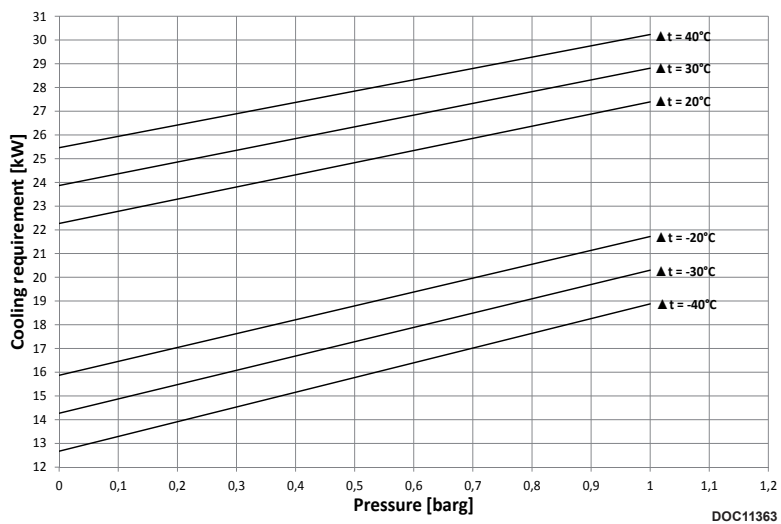

### 3.7 Pipe system



The exhaust from the liquid separator will have the same zone classification as the pump's suction side.

The pipes that are connected to the pump's suction and outlet sides must be at least the same dimension as the pump. The length of the pipe system affects the pump's capacity and should be calculated to account for pressure drop in longer pipe installations.

Depending on the operating pressure, longer pipe lengths may affect the pump's output. For pipe lengths greater than 10 metres, a pressure drop calculation should be made, and the pipe dimensions should be increased so that the pressure loss is held to an acceptable level.

The pipe system should be mounted so that the horizontal pipes have a min. of 1% decline back towards the liquid separator.

Table below can be used for reference values.

Connection	Length < 10 metres	Length 10-50 metres	Length 50-100 metres
Suction side	Min. DN 50	Min. DN 65	Min. DN 100
Outlet side	Min. DN 50	Min. DN 65	Min. DN 100

The outlet from the liquid separator should be led outside of the building because the outlet air is warm and humid.

With respect to the exhaust, measures must be put in place to account for damp air that may form ice in cold surroundings.

### 3.8 Suction filter

In installations where there is a risk of sucking foreign elements into the pump, a filter must be mounted on the pump's suction side with a maximum mesh size of 2 mm.

### 3.9 Service liquid requirements

Only water-based liquid may be used as service liquid.

For operating conditions where there is a risk of ice formation in the service liquid system, a suitable anti-freeze must be used.

# 4 INSTALLATION AND START-UP

## 4.1 Securing the pump



If the tolerance for securing the pump is not observed, there is a risk of damage and of potential explosion.

The pump must be installed on a stable foundation, which must be level and stable, so that the pump is not twisted or exposed to a  $\pm 0.2$  mm profile distortion.

The pump must be anchored with M12 foundation bolts on all four legs, which must be tightened to 60 Nm. (A)

The pump's suction and pressure connection pipes must face vertically upwards at max.  $\pm 5^\circ$ .

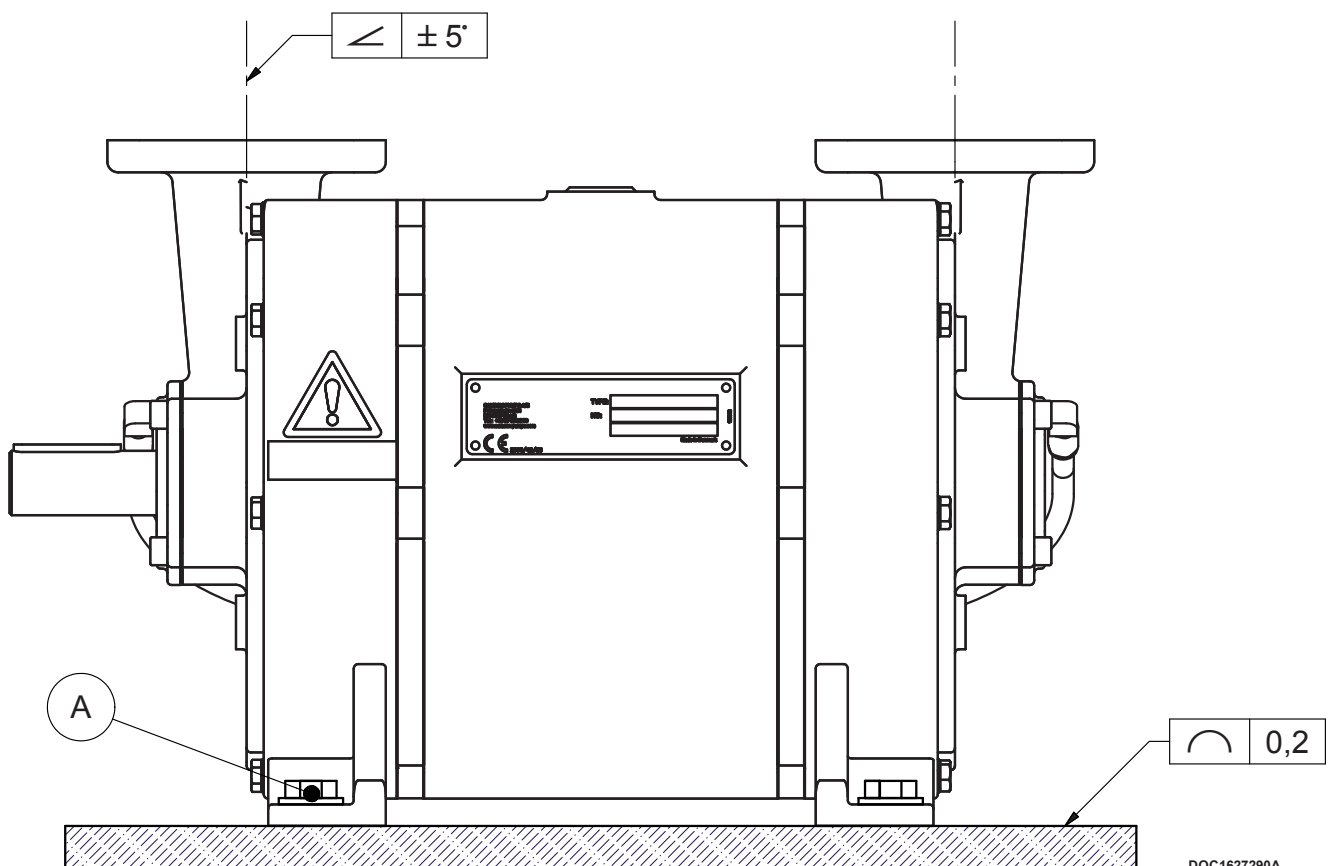

DOC1627290A

## 4.2 Connections to the pump



External effects on the pump may lead to leakage and, as a result, a potential risk of explosion.



- Check for foreign objects in the pump and physical damage on pump.
- Gaskets to be handled with highest degree of caution.
- Gasket and sealing surfaces must be cleaned before assembly.

Immediate before connecting the pipes, remove protective covers. Connection of the pump's suction and pressure pipe connections must be made with a gasket in between. (C)

The M12 bolts must be tightened to 60 Nm. (B)

In order to prevent tensions in the pump, the pipe connections (A) must be tensionless while tightening the bolts.

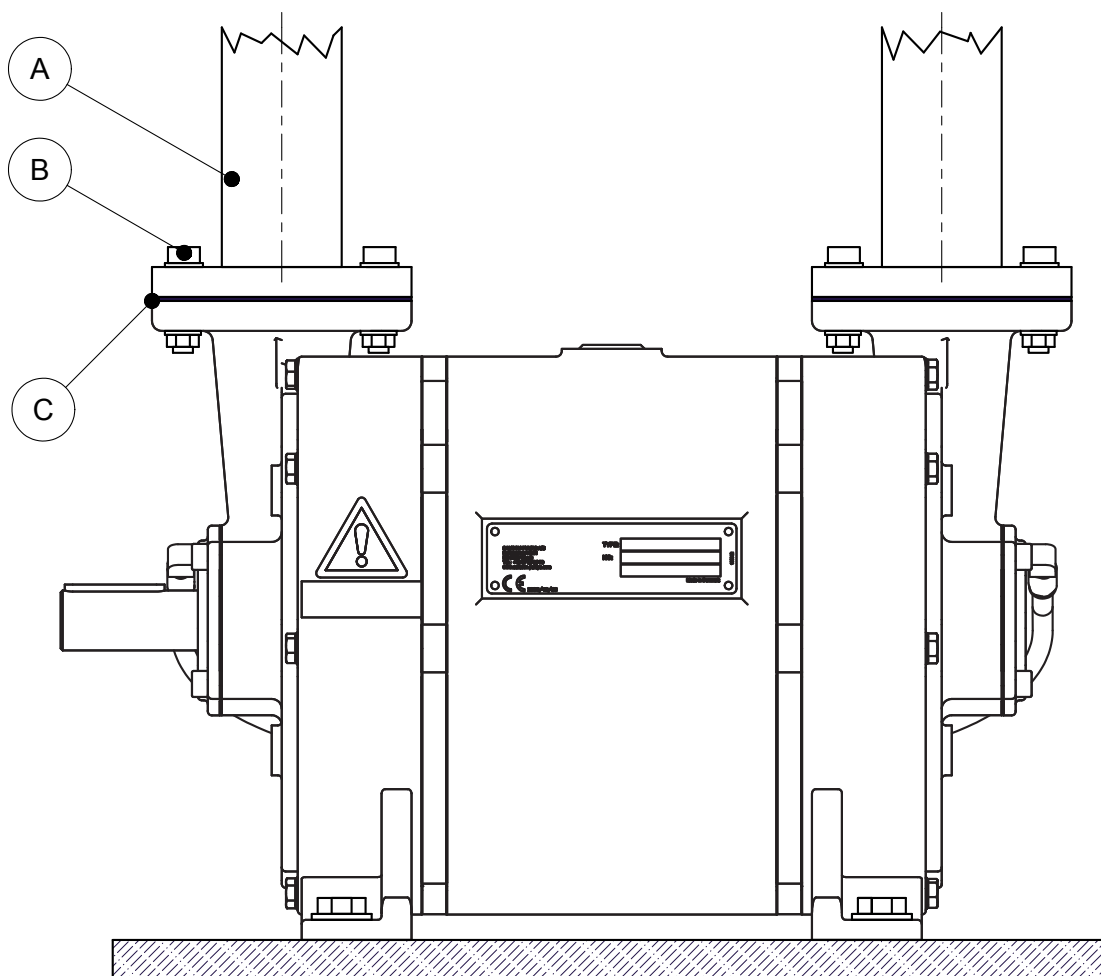

DOC1627290\_1A

### 4.3 Connecting the service liquid



The service liquid supply must be laid out in accordance with the system layout, which is described in section 3. An incorrect layout may result in a risk of explosion.

The service liquid connection must be established on both ends of the pump to ensure optimal working conditions for the pump, and so that the mechanical shaft seals are lubricated by the service liquid.

A valve is to be mounted on the connection, which can open and close the service liquid supply independently of the pump.

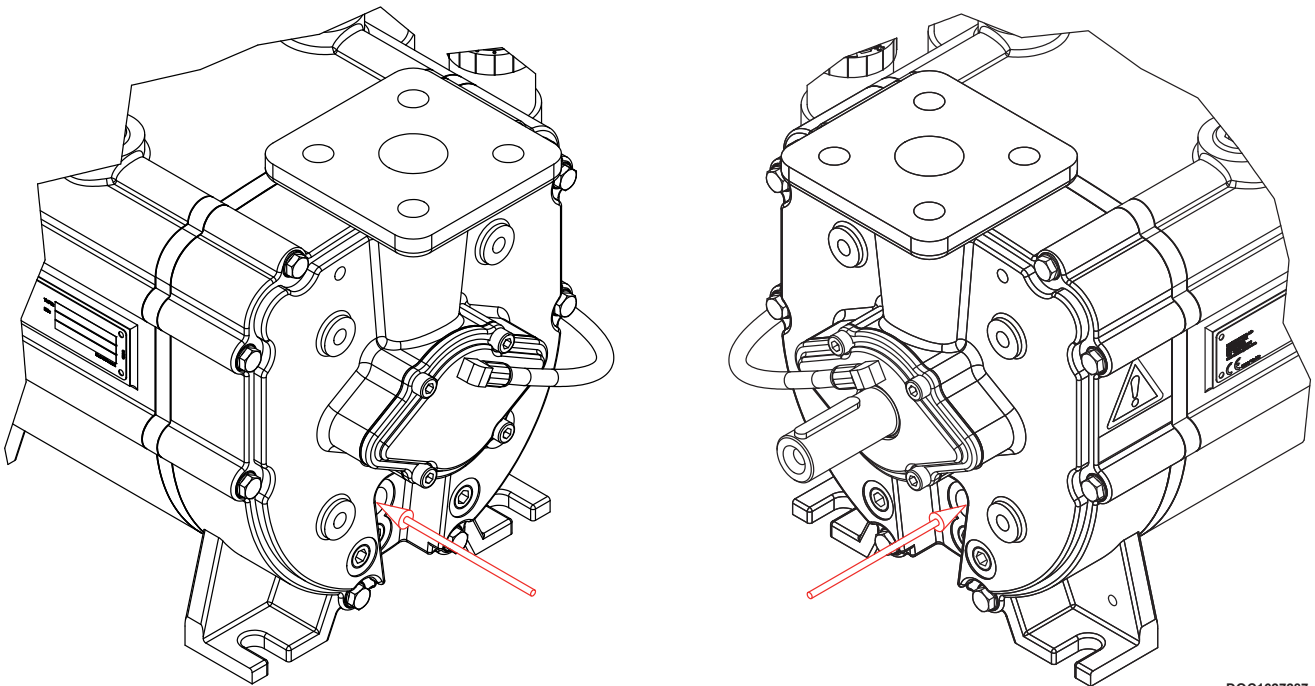

DOC1627287\_1

### 4.4 Transmission

The pump can be connected to direct or belt transmission. For belt transmission, it must be ensured that the permissible radial force is not exceeded. See specifications.

The transmission must be suitable for use in the zone in question, and the supplier's instructions for installation, service and operation must be followed.

---

## 4.5 Earth connection requirements



The pump must be connected to earth to prevent static electricity. Static electricity is a potential source of ignition.

The pump must be protected from the creation of sparks in connection with static electricity, in accordance with the applicable regulations for use in the current categories.

The pump is prepared for earth connection with an M8 threaded hole.

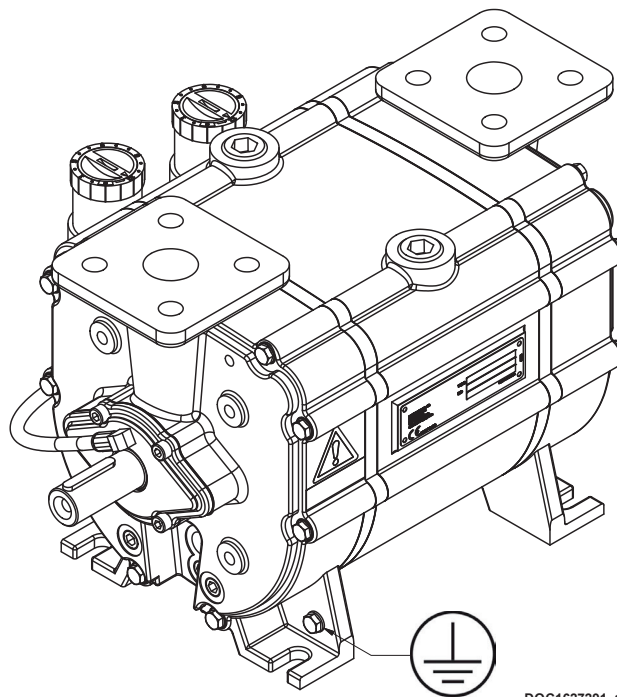

DOC1627291\_1A

## 4.6 Prior to start-up



- Do not start the pump without service liquid as this will damage the mechanical shaft seals.
- Do not start the pump if it is overfilled with service liquid.
- Do not start the pump before the grease cartridges have been activated as this can damage the pump. (If equipped with grease cartridges)
- Stop the pump immediately if the rotational direction does not correspond to the directional arrow.
- A failure to follow the above guidelines may result in damage to the pump.

### Activating the grease cartridges

Turn the knob on both grease cartridges clockwise to position 12.

Grease cartridges are a part of safety device ONLY by Zone 0/1.



## 4.7 Direction of rotation

Check the direction of rotation by briefly starting the pump.

The direction of rotation of the rotor must correspond to the direction arrow!

Below left, a right-side pump is shown which has a clockwise direction of rotation. (CW)

Below right, a left-side pump is shown which has a counter-clockwise direction of rotation. (CCW)

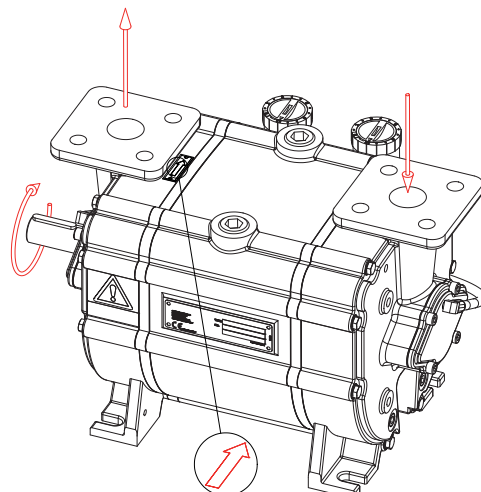
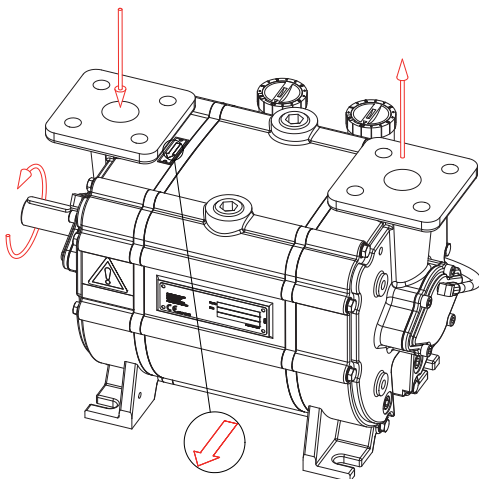



# 5 SERVICE, MAINTENANCE AND INSPECTION INTERVALS



A failure to observe the inspection intervals described in table below, may result in damage to the pump and a potential risk of explosion.

Section	Operation	Interval	Category 1	Category 2
5.1	Inspection of bearings	Daily	X	
5.2	Visually inspect for leakage	Weekly	X	X
5.3	Drain liquid separator to remove contaminants	Weekly	X	X
5.4	Check grease cartridges	Weekly	X	X*
5.5	Lubrication of bearings	Monthly		X
5.6	Inspection of ATEX safety device	Monthly	X	
5.7	Inspection and cleaning (if necessary) of service liquid's supply pipe	Monthly	X	X
5.8	Calibration of ATEX safety device	Annually	X	
5.9	Overhaul of pump	3 years/10,000 operating hours	X	
6	Troubleshooting	As required	X	X

\* -Grease cartridges are a part of safety device ONLY by Zone 0/1.

## 5.1 Inspection of bearings

The bearings of pump must be inspected once a day.

The measurements are performed after MIN. 30 min. of operation.

If operation time is less than 30 min., perform the measurements immediately after longest period of operation.

Temperature of bearings must not exceed the permitted temperature in table below.

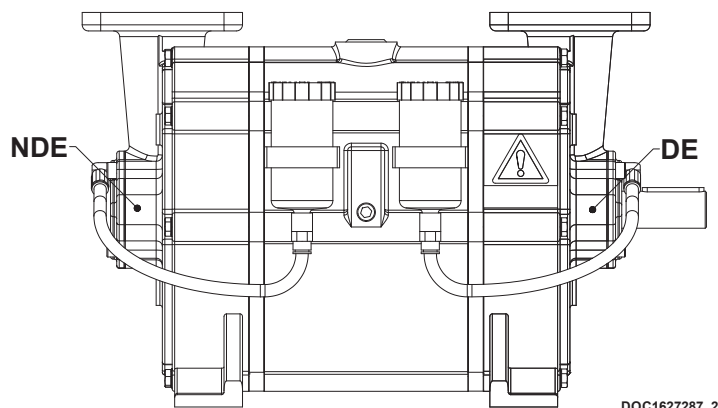

Pump	KL350	KL430
Drive end (DE)	88°C	88°C
Non drive end (NDE)	88°C	88°C

## 5.2 Inspecting for leakage

The pump and pipe system around the pump must be inspected for leakage once a week. The inspection must be performed when the pump is both operating and idle. Any leaks must be repaired before operation may continue.

### 5.3 Draining the liquid separator

While the pump is stopped, the liquid separator must be drained to remove contaminants.

### 5.4 Check grease cartridges (Category 1 pumps and category 2 pumps with grease cartridges)



To prevent electrostatic discharge in hazardous areas, only wet cleaning is permitted. Appropriate measures must be taken to prevent electric discharge.

The pump is equipped with an automatic lubrication feature, which must be inspected and replaced as needed.

When the pump is commissioned for the first time, the cartridges must be activated by turning the arrow in the clockwise direction.

The cartridge is set to 12, which corresponds to an emptying time of 12 months. The cartridge must be replaced when empty.

It is only allowed to use automatic lubricator of type **LAGD 125/WA2**.



DOC3707

### 5.5 Lubrication of bearings (Category 2 pumps without grease cartridges)



Over-lubrication of bearings may result in bearing failure! Do NOT exceed the amount of grease specified below!

The bearings must be lubricated with grease of type SKF LGWA2, once a month. It is recommended to lubricate the bearings while pump is running.

Pump	KL350	KL430
Drive end (DE)	2 g/mth	2 g/mth
Non drive end (NDE)	2 g/mth	2 g/mth

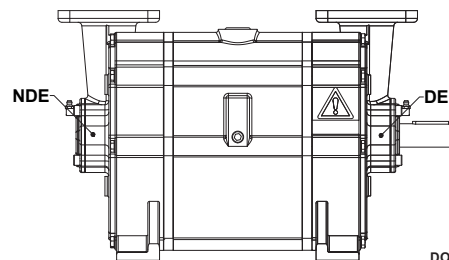

DOC1627287\_5

---

## 5.6 Inspection of ATEX safety device



ATEX safety device must be inspected in accordance with table to ensure proper functionality. A failure to perform the required inspections will result in the discontinuation of the pump's approval.

Safety devices to be inspected in accordance with applicable regulations.

The components that make up the safety device can be found in the system layout in section 3.

## 5.7 Inspection and cleaning of service liquid's supply pipe

The pipe connection between the liquid separator and pump must be inspected at least once a month, and any contaminants must be removed.

## 5.8 Calibration of ATEX safety device

The flow and level meter must be calibrated once a year in accordance with the applicable requirements. The pump may not be started before the instruments have been re-installed.

## 5.9 Overhaul of pump

The pump must be serviced every three years or after 10,000 operating hours (whichever comes first). This is done by sending the pump to Samson Pumps, or approved and certified partner, upon agreement. The pump must be cleaned. Only for category 1 pumps, not category 2.

Repairs carried out on ATEX pumps may only be performed by Samson Pumps, or approved and certified partner. If this requirement is not observed, and the pump's seal is broken, the pump's declaration of conformity shall no longer apply and Samson Pumps shall be relieved of all responsibility for any resulting consequences.

# 6 TROUBLESHOOTING

Problem	Cause	Effect	Corrective measure
<b>The pump is unable to create a vacuum</b>	<ul style="list-style-type: none"> <li>The pump is not receiving enough service liquid</li> <li>The temperature of the service liquid is too high</li> </ul>	<ul style="list-style-type: none"> <li>Reduced output</li> <li>The pump can become damaged during cavitation</li> </ul>	<ul style="list-style-type: none"> <li>Check the liquid supply</li> <li>Stop the pump and wait until the temperature has dropped to a sufficient level, or lower the temperature of the service liquid inlet.</li> </ul>
<b>Power consumption too high during operation</b>	<ul style="list-style-type: none"> <li>The pump is receiving too much service liquid</li> </ul>	<ul style="list-style-type: none"> <li>The pump can become worn</li> </ul>	<ul style="list-style-type: none"> <li>Check the liquid supply</li> </ul>
<b>The start-up power is too high</b>	<ul style="list-style-type: none"> <li>Too much service liquid in the pump prior to start-up</li> </ul>	<ul style="list-style-type: none"> <li>Noise at start-up and possible overload of the power supply</li> </ul>	<ul style="list-style-type: none"> <li>Check the stop valves in the liquid supply for leakage</li> </ul>
<b>Noise during operation</b>	<ul style="list-style-type: none"> <li>Cavitation</li> </ul>	<ul style="list-style-type: none"> <li>Severe damage to the pump and potential risk of breakdown</li> </ul>	<ul style="list-style-type: none"> <li>Increase the suction pressure or lower the temperature of the service liquid</li> </ul>
<b>Leakage from the bearing housing's drain holes</b>	<ul style="list-style-type: none"> <li>Damaged shaft seal</li> </ul>	<ul style="list-style-type: none"> <li>Bearings may become damaged</li> <li>Potential risk of explosive gas leak</li> </ul>	<ul style="list-style-type: none"> <li>Stop the pump and contact the manufacturer</li> </ul>
<b>The pump stops due to too little service liquid being fed into the system</b>	<ul style="list-style-type: none"> <li>The liquid supply is clogged</li> </ul>	<ul style="list-style-type: none"> <li>Operations stopped</li> </ul>	<ul style="list-style-type: none"> <li>Check the liquid supply</li> </ul>
<b>The pump stops due to excess outlet temperature</b>	<ul style="list-style-type: none"> <li>The pump is not receiving enough service liquid</li> <li>The temperature of the suctioned gas is too high</li> </ul>	<ul style="list-style-type: none"> <li>Operations stopped</li> </ul>	<ul style="list-style-type: none"> <li>Check the liquid supply</li> <li>Lower the temperature of the gas</li> </ul>

---

**Notes:**

---

---

---

---

---

---

---

---

---

---

---

---

---

---

---

---

---

---

---

---

---

---

---

---

---

---

---

---

---

---



---

**Notes:**

---

---

---

---

---

---

---

---

---

---

---

---

---

---

---

---

---

---

---

---

---

---

---

---

---

## **SAMSON PUMPS**

Samson Pumps is the only company in the world to specialise exclusively in liquid ring vacuum pumps. Samson pumps are made in Denmark and used around the globe. We offer worldwide delivery, and we export to more than 80 countries around the world.

For over 40 years, our name has been synonymous with the strongest pumps for vacuum trucks and tankers. We constantly adapt our products to meet the changing needs of our customers. Today, it is not enough to simply produce a pump. Products must be refined so the customer can concentrate on what they do best. We therefore offer a wide range of standardised components that allow our customers to build vacuum systems without the need for specialist in-house expertise.

Strength and durability are our hallmarks! We have often heard from customers that our pumps are working in many years, and in most cases without the need for maintenance or repair. This emboldens us to say that we have the strongest program of pumps on the market.