

INSTRUCTION MANUAL

LIQUID RING PUMP



TRUCK MASTER[®] 350

INSTRUCTION MANUAL FOR SAMSON LIQUID RING PUMP
TRUCK MASTER 350

- Technical data
- Design of a system
- Installation and start-up
- Service
- Troubleshooting
- Spare parts

CONTENTS

1	Introduction	4
1.1	Declaration of conformity.....	4
1.2	Explanation of warning symbols.....	5
1.3	Field of application.....	5
1.4	Disposal.....	5
2	Technical data.....	6
2.1	Dimensions.....	6
2.2	Specifications.....	7
2.3	Power consumption and output.....	8
2.3.1	Vacuum	8
2.3.2	Pressure.....	8
2.3.3	Correction factor – Temperature	9
2.3.4	Correction factor – Wet and dry gas.....	9
2.4	Handling and transport	10
2.5	Pump storage and draining procedure.....	11
3	Design of a system	12
3.1	Function and design of a liquid separator.....	13
3.2	Air cooling with fan cooler	14
3.3	Fan cooler	15
3.4	Water consumption	16
3.5	Dome valve system	16
3.6	Cavitation	17
3.7	Service liquid requirement.....	17
4	Installation and start-up.....	18
4.1	Securing the pump.....	18
4.2	Connections to the pump.....	18
4.3	Connecting the service liquid	19
4.4	Transmission	19
4.5	Prior to start-up.....	20
4.6	Direction of rotation	20

5	Service, operation, maintenance and inspection intervals.....	21
5.1	Draining the liquid separator.....	21
5.2	Check grease cartridges	21
5.3	Winterization.....	21
5.4	Lubrication of bearings	22
5.5	Inspection and cleaning of service liquid's supply pipe.....	22
5.6	Inspection and cleaning of internal channels	22
6	Troubleshooting	23
7	Spare parts and tools.....	24
7.1	Marking and identification.....	24
7.2	How to order.....	25
7.3	Spare parts.....	26
7.4	Adaptor.....	30
7.5	Gasket set.....	31
7.6	Special tool set.....	32

1 INTRODUCTION

1.1 Declaration of conformity

SAMSON PUMPS

Declaration of Conformity

Annex IIA

Samson Pumps A/S

Petersmindevej 21
DK-8800 Viborg

Hereby declares that the following products:

Liquid ring pump
Truck Master 350, Truck Master 600, Truck Master 1600, Truck Master 2500,
Truck Master 3400, SLP 2100, SLP 2700, SLP 3100

Conforms to the directive:

Machinery Directive 2006/42/EC

I hereby declare that the liquid ring pumps are in conformity with the following harmonized standards:

DS/EN ISO 12100:2011	Safety of machinery – General principles for design – Risk assessment and risk reduction
DS/EN 1012-2 + A1:2009	Compressors and Pumps – Safety requirements – Part 2: Vacuum pumps

The standards above only apply to the extent that it is relevant for the purpose of the pump. The product must not be used before the complete system, which it must be incorporated in, has been conformity assessed and found to comply with all relevant health and safety requirements of 2006/42/EC and other relevant directives. The product must be included in the overall risk assessment.

Viborg, 16.12.2019



Jan S. Christiansen – Manager, Technical dept.

DOC4044A

E-Mail	info@samson-pumps.com	Samson Pumps A/S	Petersmindevej 21
Web	www.samson-pumps.com	Phone +45 87 50 95 70	DK-8800 Viborg

1.2 Explanation of warning symbols

Important technical and safety instructions are shown by symbols. If the instructions are not performed correctly, it can lead to personnel injuries or incorrect function of the pump.



To be used with all safety instructions that must be followed. A failure to follow the instructions may result in injuries and/or incorrect machine operation

1.3 Field of application



Inlet of foreign objects can damage the pump



The pump is designed exclusively to pump gases, including atmospheric air



WARNING!
Avoid cavitation of the pump! For further information, see instruction manual for the Samson Pumps vacuum limiter

It must be ensured that the inlet gas cannot react with the service liquid and create aggressive bonds that break down the pump's components.

For other operating data, see specifications.

- The pump must only be used with media that is not aggressive to the pump's materials. See section 7 for components and materials.

1.4 Disposal

Samson's liquid ring pump is manufactured so that most of the device can be reused/recycled.

Samson Pumps offer users of the company's pumps the option of returning used pumps to be restored or scrapped.

Alternatively, the pump must be taken apart and sorted into its separate components, by the customer (see section 7 for the pump's material).

These components must be disposed of in accordance with national regulations.

2 TECHNICAL DATA

2.1 Dimensions

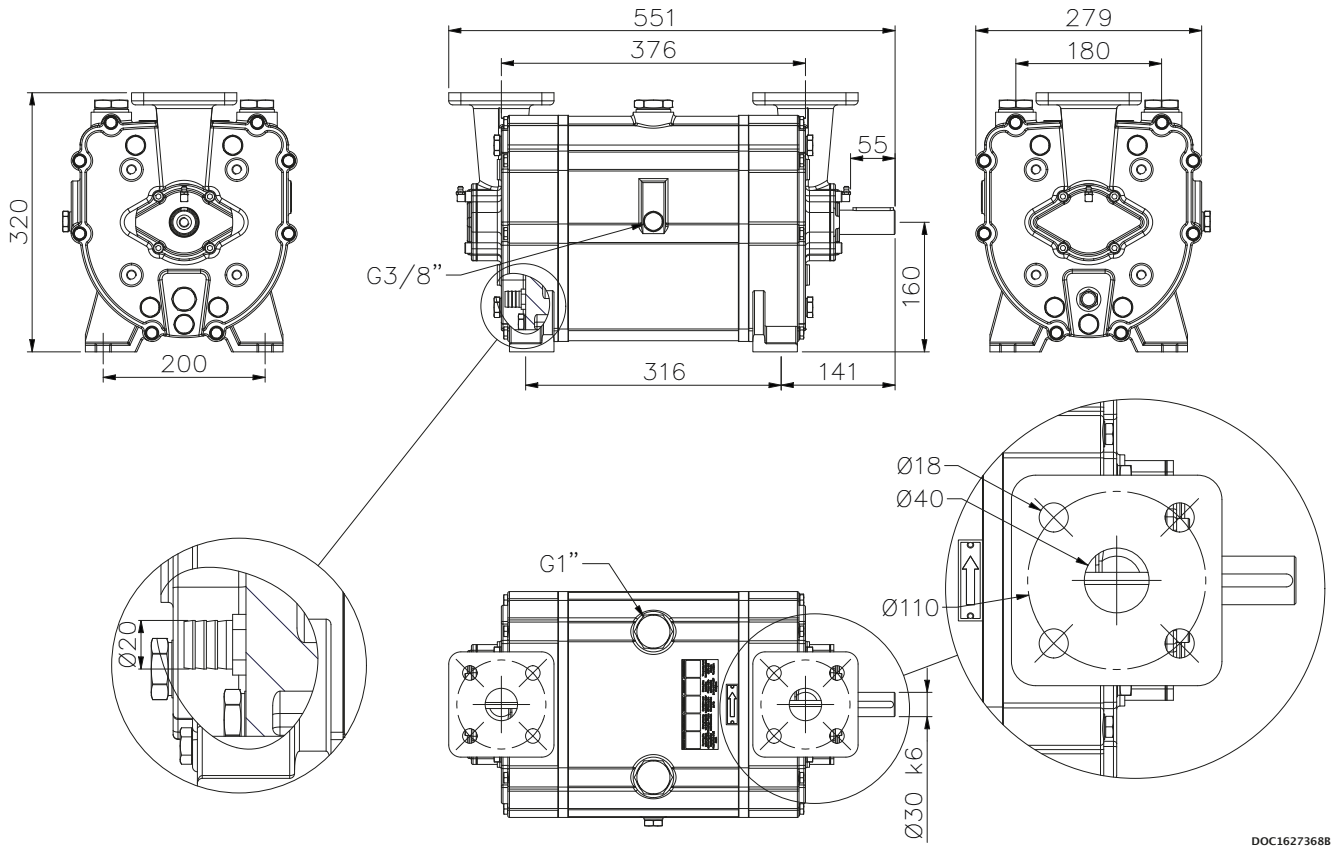

DOC16273688

2.2 Specifications



A failure to meet these specifications may result in damage to the pump

Description		Minimum	Maximum
Ambient temperature, operation	Below 0°C – see chapter 5.3	-20°C	55°C
Ambient temperature, storage		-20°C	55°C
Humidity		-	100%
Intake temperature, suction side		-	60°C
Intake temperature, service liquid		-	60°C
Service liquid pipe connection, dimension		½"	-
Service liquid pipe connection, length		-	6 m
Noise level		-	70 dB(A)
Water volume		-	7 L
Maximum radial load on drive shaft		-	1400 N
Heat input for cooler calculation	1200 rpm	4 kW	-
	1500 rpm	5 kW	-
	1650 rpm	6 kW	-
	1800 rpm	7 kW	-
Revolutions		1200 rpm	1800 rpm
Pressure		150 mbar abs.	1 bar(g)
Lubricating grease	Type of grease	SKF LGWA2	
	Automatic lubrication	SKF LAGD 125/WA2	
Weight		84 kg	

2.3 Power consumption and output

2.3.1 Vacuum

	Vacuum	[%]	80	70	60	50	40	30	20
1200 [rpm]	Flow _{Wet}	[m ³ /h]	106	177	192	190	199	202	212
	Flow _{Dry}	[m ³ /h]	78	139	167	168	183	187	198
	Consumption	[kW]	6						
	Torque	[Nm]	44						
1500 [rpm]	Flow _{Wet}	[m ³ /h]	193	230	220	240	242	253	254
	Flow _{Dry}	[m ³ /h]	142	179	191	212	222	234	238
	Consumption	[kW]	7						
	Torque	[Nm]	41						
1650 [rpm]	Flow _{Wet}	[m ³ /h]	226	259	234	260	269	276	334
	Flow _{Dry}	[m ³ /h]	166	202	204	230	246	255	312
	Consumption	[kW]	8						
	Torque	[Nm]	43						
1800 [rpm]	Flow _{Wet}	[m ³ /h]	244	280	253	276	289	291	359
	Flow _{Dry}	[m ³ /h]	179	219	220	244	265	270	336
	Consumption	[kW]	9						
	Torque	[Nm]	48						

2.3.2 Pressure

	Pressure	[bar(g)]	0	0.25	0.5	0.75	1
1200 [rpm]	Flow	[m ³ /h]	182	165	148	120	83
	Consumption	[kW]	3	4	6	7.5	8.5
	Torque	[Nm]	24	32	48	60	68
1500 [rpm]	Flow	[m ³ /h]	277	260	244	219	151
	Consumption	[kW]	4	6	8	10	12
	Torque	[Nm]	25	38	51	64	76
1650 [rpm]	Flow	[m ³ /h]	300	282	272	256	239
	Consumption	[kW]	5.5	7.5	9.5	11	13.5
	Torque	[Nm]	32	43	55	64	78
1800 [rpm]	Flow	[m ³ /h]	325	309	287	277	266
	Consumption	[kW]	6.6	8.7	11	13	15
	Torque	[Nm]	35	46	58	69	80

The data Flow_{Dry} is based on the following parameters:

- Air temperature 20°C
- Service liquid temperature 15°C
- Test performed with dry air and 1,013 mbar absolute pressure
- Tolerance ±10%

2.3.3 Correction factor – Temperature

When the temperature of the service liquid exceeds 15°C, the pump’s capacity will be affected with respect to the specified values.

To determine the output at a higher temperature, the correction factor can be used.

Capacity at service liquid temperature higher than 15°C :

$$Q_{t>15} = Q_{15} \times K_1$$

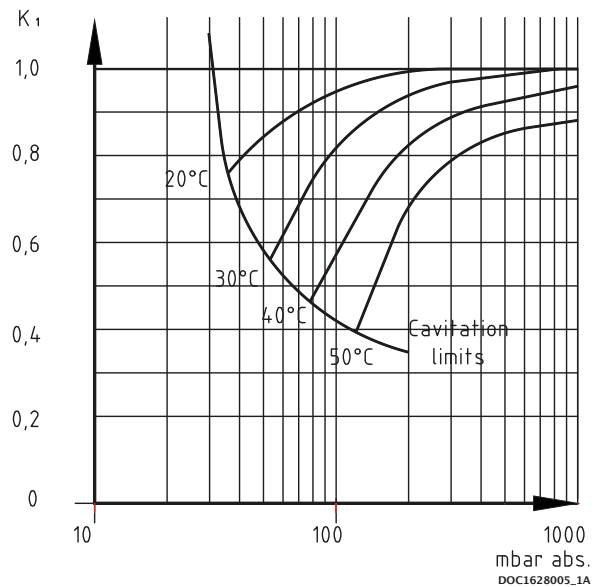

2.3.4 Correction factor – Wet and dry gas

Normal atmospheric air contains water vapor. In this case water will condense inside the pump and will create a higher flow.

Below you can find a correction factor table for the performance based on condensing gas with an inlet temperature of 50°C 100% saturated and service liquid temperature of 15°C.

Suction pressure % Vacuum	80	70	60	50	40	30	20
Correction factor wet gas K_{Wet}	1,34	1,28	1,15	1,13	1,09	1,08	1,07

The performance of the pump can thereby be calculated as:

$$V_{Wet} = V_{Dry} \times K_{Wet}$$

2.4 Handling and transport



The pump must not be used if it is damaged or the identification plate is missing

The pump must be transported in such way that it is not exposed to vibrations and impacts that can overload the bearings.

The pump must be inspected for damages upon delivery. If the pump is damaged, it must not be used and the damage must be reported to the manufacturer.

Ensure that the pump's identification plate is intact and that the marking of the pump corresponds to its use.

The pump must only be handled using approved lifting eyes, in accordance with nationally applicable regulations and only in a vertical motion.

The pump can be transported in the following ways:

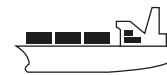
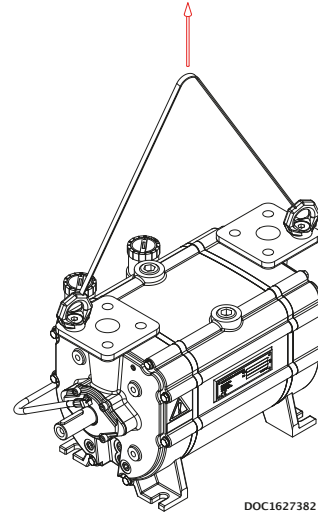

2.5 Pump storage and draining procedure



A failure to comply with the requirements for storing the pump may result in internal damage to the device



If the temperature is below freezing point of the service liquid, it could damage the pump. Under these conditions, the pump must be drained completely.



All plugs and protective covers must be fitted during storage.

The pump's service liquid is drained on delivery, and the pump can be immediately stored in accordance with the technical specifications.

After operation, the pump can be stored for 30 days without further action.

If the pump remains out of operation for a longer period of time after use, its service liquid must be drained, and the liquid supply to the pump must be shut off.

When emptying the pump, it is important that all chambers inside the pump are emptied.

The pump can be fitted with valves in the draining connections. See below.

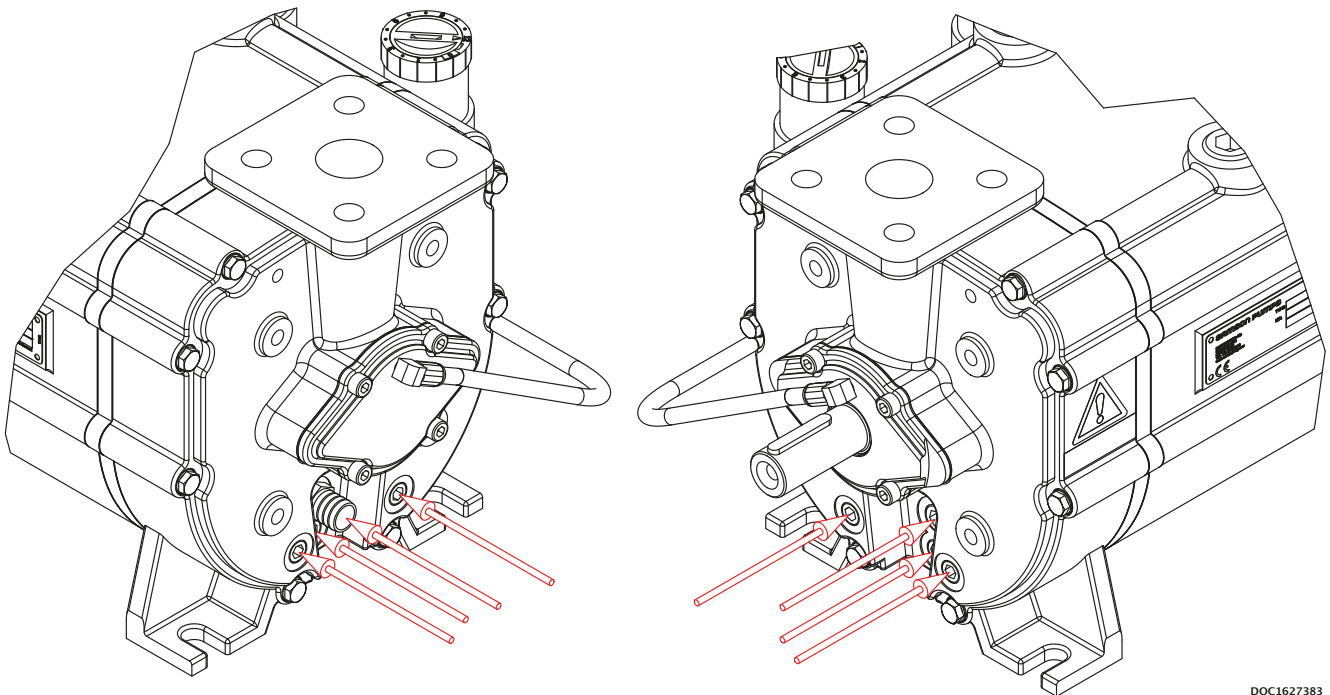

DOC1627383

3 DESIGN OF A SYSTEM

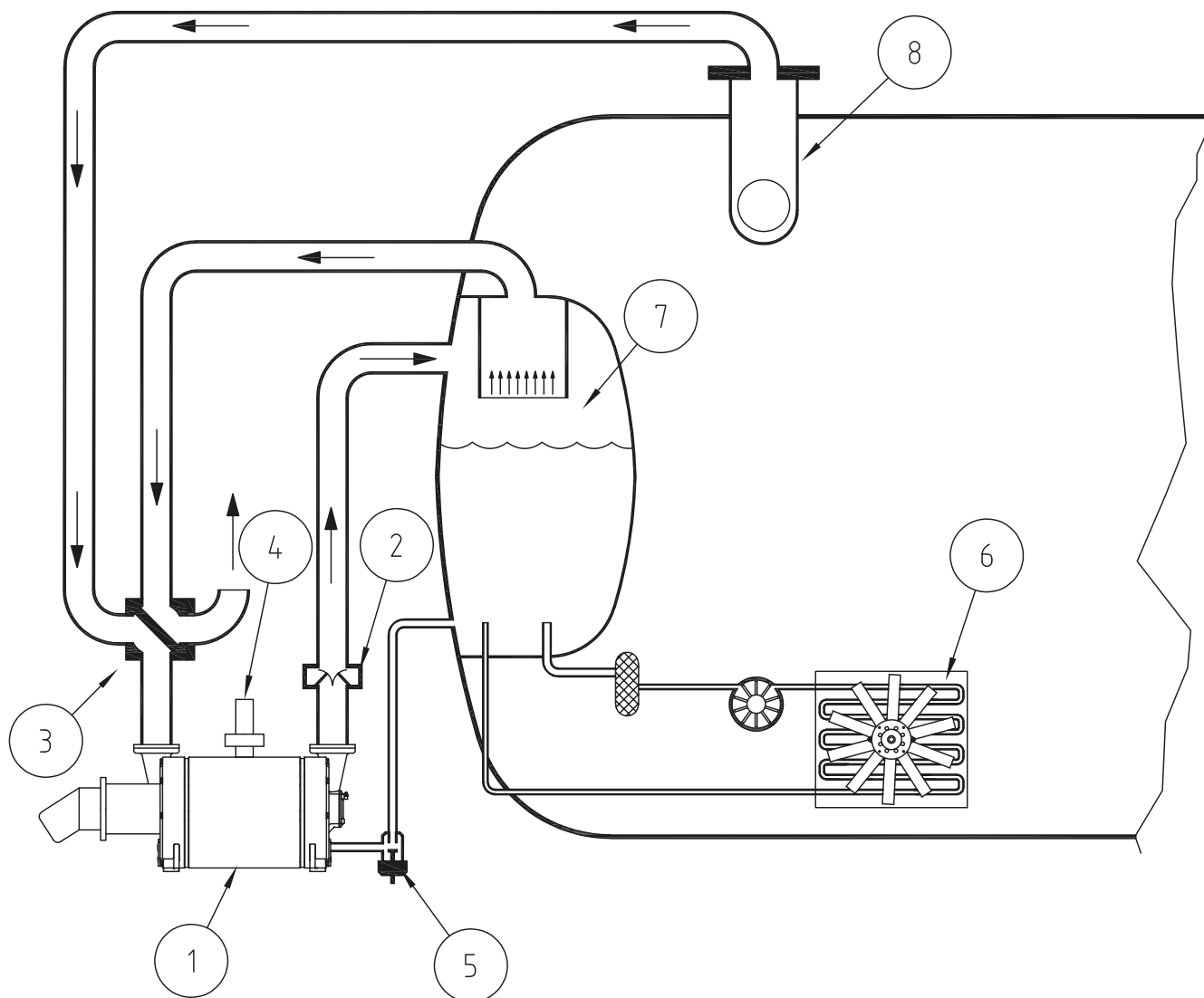

DOC1627390

Pos.	Description
1	Liquid ring pump
2	Non return valve
3	4-way valve
4	Vacuum limiter
5	Service liquid valve
6	Fan cooler
7	Liquid separator
8	Dome valve

3.1 Function and design of a liquid separator

Together with the air there will be a water flow out of the pump up to 6 m³/h.

The water will be separated from the air in the liquid separator.

Depending of the size of particles, water will be carried with the water when the air velocity is more than 3-4 m/s.

The inlet speed to the separator can be more than 50 m/s and this must be reduced to 3 m/s.

Below you find an illustration showing how to reduce the speed and control that no water will be in contact with the high velocity air stream. The round velocity reducer can be placed inside any tank geometry.

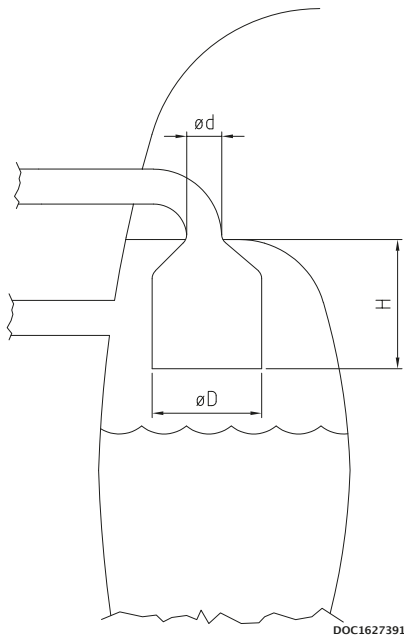

Air flow [m ³ /h]	$\varnothing D$ minimum [mm]
350	200
325	195
300	185
275	180
250	170
225	160

$\varnothing D$ so the velocity is below 3 m/s

$H=4$ to $6 \cdot d$ depending on the geometry. A smooth diameter conversion will give a low factor.

3.2 Air cooling with fan cooler

Compression of air inside the liquid ring pump will create heat that is transferred to the service liquid. Therefore, it can be necessary to install a fan cooler depending on the expected use, the climate etc. The time it takes to heat up the water also depends on for example ambient temperature, suction pressure, amount of water and the cooling effect in the truck itself.

The operation temperature will go up until there is a balance between the heat input and the heat output. So basically, there are only two things that can lower the operation temperature. Reduce the heat input or increase the heat output.

The amount of water has no or only a little influence on the final operating temperature. The truck itself will work as a big radiator and if there is a huge amount of water in the liquid separator and thereby good contact area between the water and the steel tank, it will give a higher cooling effect. This in combination with low ambient temperature and short time of operation, could mean that the truck can operate without any additional cooling.

In general, the time it takes to heat up the water can be calculated from the formula below.

$$t_{\text{sec}} = \frac{C_p \times m \times \Delta t}{Q}$$

t_{sec} = Time in seconds

C_p = Heat capacity of the media. Water= 4,2

Δt = Temperature difference

m = Mass of the media heating up [Kg]

Q = Heat input in [kW] See specifications, chapter 2.2

Example:

We have a tank with 100 litres of water corresponding to 100 kg. The heat input is 8 kW. How long will it take to heat it up from 20°C to 40°C ?

$$t_{\text{sec}} = \frac{4,2 \times 100 \times 20}{30} = 1050 \text{ s} = \underline{17,5 \text{ min}}$$

The temperature will continue to go up until the steel construction can absorb the heat and transfer it to the surroundings.

With a temperature difference on 20°C it is typical to have a radiator effect in a truck on somewhere between 1 to 4 kW depending on the construction.

The table below shows truck radiator effect at a temperature difference of 20°C.

1 kW	2 kW	4 kW
Small liquid separator mounted external from the truck tank Water content below 20 L	Small liquid separator inside slurry tank. Located with only minor contact to the product Water content 50 L	Normal liquid separator inside slurry tank with good contact to the product Water content 100 L

3.3 Fan cooler

The fan cooler will increase the heat output from the construction and thereby stabilize the temperature at a lower level. However, this cooler will use the air to cool down the water and therefore we will always see that the temperature will be stabilized above the ambient temperature. It's very simple to find the right cooler based on the curves from the cooler manufacturer. Typically you will find the cooler capacity as kW/Δt meaning for example 1.5 kW cooler capacity each °C in temperature difference between the water and the air. Note that the water flow through the cooler will also affect the cooling capacity.

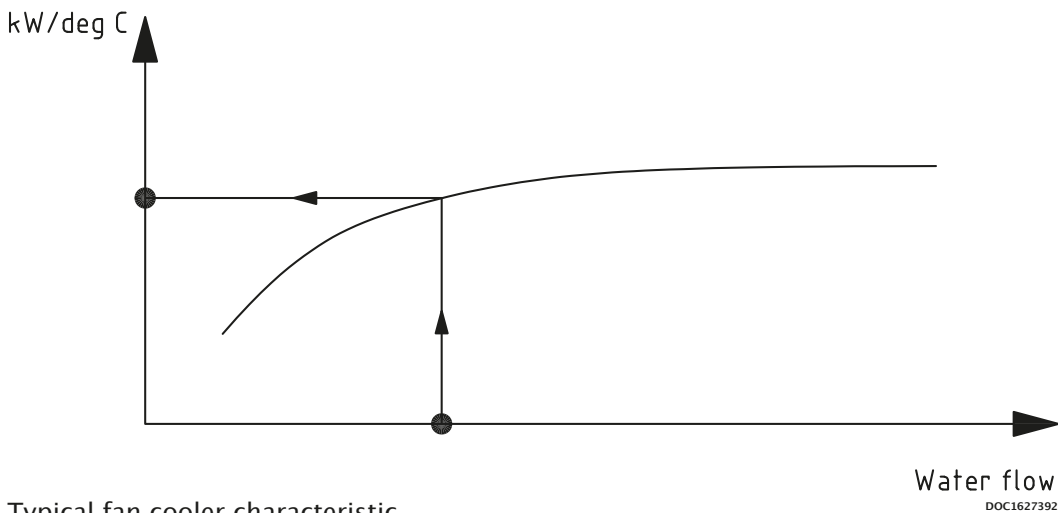

Practical calculation example:

The truck is used mostly to work with an operation pressure around 70% vacuum. From the technical data sheet, we find the heat input from the pump to be 6 kW.

The liquid separator is built inside the slurry tank with a good contact to the product and a radiator effect estimated to 4 kW with a temperature difference of 20°C.

The truck will work with ambient temperature up to 28°C during the summer and we will accept a maximum temperature on 40°C.

First, we have to reduce the radiator effect based on a temperature difference of 12°C.

$$Q_{\text{out Truck}} = 4 \times \frac{12}{20} = 2,4 \text{ kW}$$

The total cooling effect required is thereby:

$$Q_{\text{out Pump}} - Q_{\text{out Truck}} = 6 - 2,4 = \underline{3,6 \text{ kW}}$$

Summary

Pump model	Description	Truck Master 350
Heat input from technical specifications	$Q_{in Pump}$	6 kW
Ambient temperature	t_{amb}	28°C
Maximum Working Temperature of the water. This is determined by you. The temperature has influence on the pump performance	t_{op}	40°C
Temperature difference	Δ_t	$t_{op} - t_{amb} = 12^\circ\text{C}$
Truck radiator effect based on 20 °C in temperature difference	$Q_{out Truck 20}$	4 kW
Truck radiator effect based on 12 °C in temperature difference	$Q_{out Truck 12}$	$4 \cdot 12 / 20 = 2,4 \text{ kW}$
Total cooling requirement from fan cooler	$Q_{fan cooler}$	$Q_{in Pump} - Q_{out Truck 12} = 6 - 2,4 = 3,6 \text{ kW}$

We need to find a fan cooler that can transfer 3,6 kW with a temperature difference on 12°C. That is 0,3 kW/°C.

If we for example accept a higher temperature, for instance 48°C, we will have full cooling effect from the truck on 4 kW and a cooling requirement on 2 kW. The fan cooler we need to find is thereby on $2/20 = 0,1 \text{ kW/}^\circ\text{C}$ and a big difference to the bigger model calculated above.

3.4 Water consumption

It is possible to design the liquid separator so that almost 100% of the water is separated from the air. However, the air will be heated up and thereby it can content more water. Also, the relative humidity will go up and end near 100%.

So, the air will flow into the pump with maybe 50% relative humidity at a low temperature and be discharged at a higher temperature and humidity. Therefore, there will be an evaporation from the system.

Choose your water temperature

Temp. \ Vacuum	20°C	30°C	40°C	50°C	55°C
50%	4	9	14	23	36
70%	3	4	8	13	21
80%	1	2	3	5	9

Water consumption Liters per hour

3.5 Dome valve system

The liquid ring pump can handle liquid and particles in the inlet but it is of course recommendable to avoid this.

A dome valve or floating valve will ensure that the suction will be closed when the liquid level reaches the top of the tank.

In many situations there will be foam on the liquid surface inside the tank. It can be difficult to avoid that this will be transported into the suction line before the dome valve will close.

Therefore, it will be recommended to make a combination of a filter and dome valve as illustrated below.

The filter will prevent particles lifted by the foam to enter the pump.

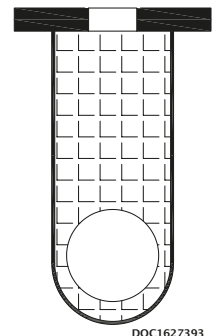

DOC1627393

3.6 Cavitation

When the temperature reaches the boiling point of the water, steam bobbles will be created in the liquid ring.

These bobbles cannot exist when they enter the discharge side of the pump and therefore they will collapse. The impact force on the surface of the rotor and flow plate will damage the pump and can lead to a total breakdown. It is a very harmful situation that must be avoided.

It is the combination of the pressure and the temperature that will lead to the cavitation. Therefore, it is recommended to install a cavitation valve, see illustration below that shows a clockwise rotating pump. If counter-clockwise rotating pump, mount in opposite hole.

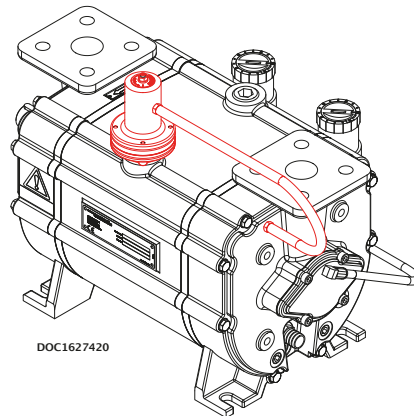

Below you find the boiling point of water as a function of the pressure.

Vacuum	50%	75%	80%	90%
Temperature °C	80	64	59	44
Maximum discharge temperature	70	50	40	30

Note that the temperature of the gas inside the pump will heat up the water and the water surface therefore will become a higher temperature than the measured temperature on the discharge side of the pump. Cavitation will therefore start at a lower temperature and the maximum discharge temperature of the water must be kept lower.

3.7 Service liquid requirement

During operation it is normal that small amount of product will enter the pump, or the gas will react with the water which becomes aggressive.

A normal recommendation is to add glycol to the water in order to protect the liquid ring pump. Glycol will protect the pump and for example the aluminum cooler, but shall only be used in periods with temperature below freezing point.

Due to economical aspect it is more efficient to drain the liquid separator and refill with fresh water instead of protecting with glycol and drain the separator more rarely.

4 INSTALLATION AND START-UP

4.1 Securing the pump



Installation requirements must be observed, otherwise there is a risk of damage

The pump must be installed on a stable foundation, which must be level and stable, so that the pump is not twisted or exposed to a profile distortion.

The pump must be installed with M12 bolts on all four legs, which must be tightened to 60 Nm (A).

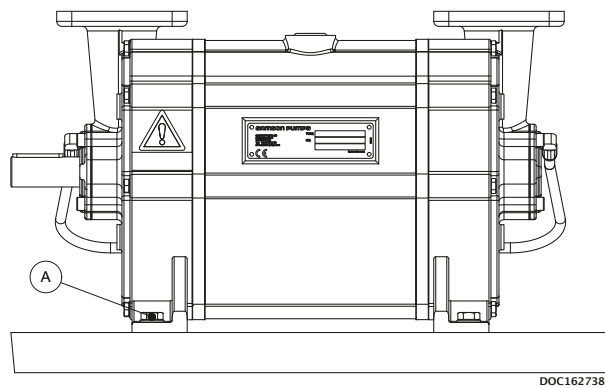

4.2 Connections to the pump



- Check for foreign objects in the pump and physical damage on pump
- Gaskets to be handled with highest degree of caution
- Gasket and sealing surfaces must be cleaned before assembly

Immediate before connecting the pipes, remove protective covers. Connection of the pump's suction and pressure pipe connections must be made with a gasket in between (C).

The M12 bolts must be tightened with 60 Nm (B).

In order to prevent tensions in the pump, the pipe connections (A) must be tensionless while tightening the bolts.

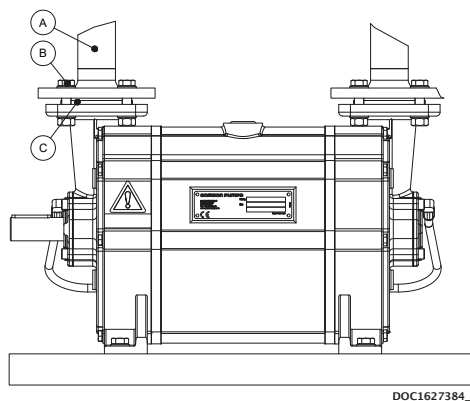

4.3 Connecting the service liquid

The service liquid must be connected to the pump at the hose connection, see illustration below.

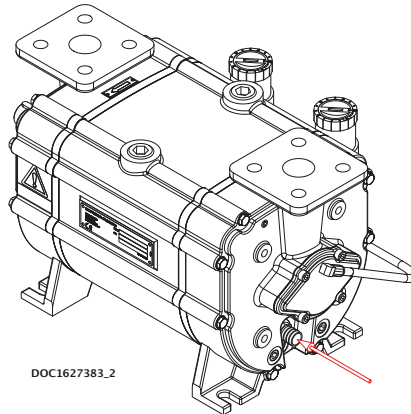

4.4 Transmission

The pump can be connected direct or through belt transmission. For belt transmission, it must be ensured that the permissible radial force is not exceeded. See specifications.

For belt transmission, note the direction of rotation, see illustration below.

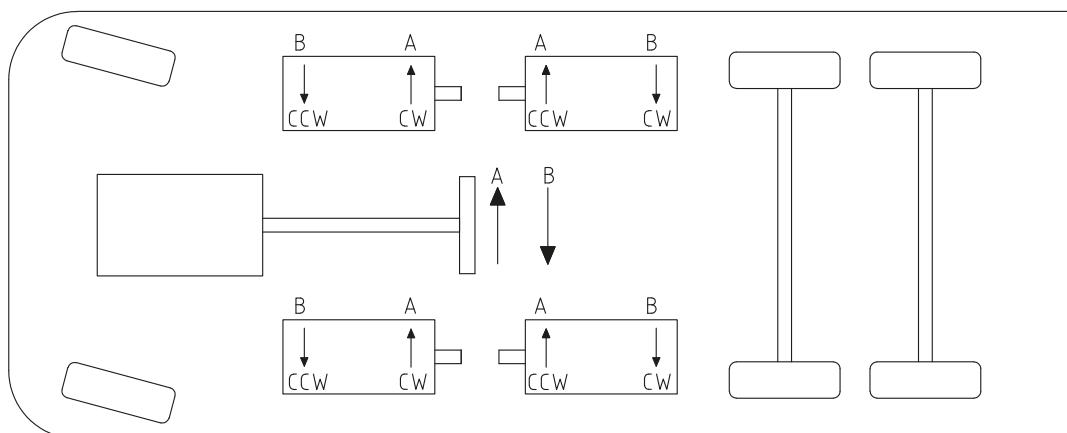

4.5 Prior to start-up



- Do not start the pump without service liquid, as this will damage the mechanical shaft seals
- Do not start the pump if it is completely filled with service liquid
- Do not start the pump before the grease cartridges have been activated, as this can damage the pump (if equipped)
- Stop the pump immediately if the rotational direction does not correspond to the directional arrow
- A failure to follow the above guidelines may result in damage to the pump

Activating the grease cartridges (Accessories)

Turn the handle in NDE clockwise to position 12.
Turn the handle in DE clockwise to position 12.
The pump has been lubricated from factory and is ready to start.



DOC3707

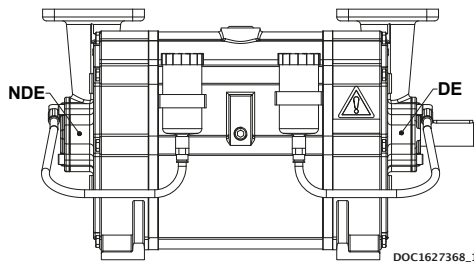

DOC1627368_1

4.6 Direction of rotation

Check the direction of rotation by briefly starting the pump.

The direction of rotation of the rotor must correspond to the direction arrow!

Below left, a right-side pump is shown which has a clockwise direction of rotation (CW)

Below right, a left-side pump is shown which has a counter-clockwise direction of rotation (CCW)

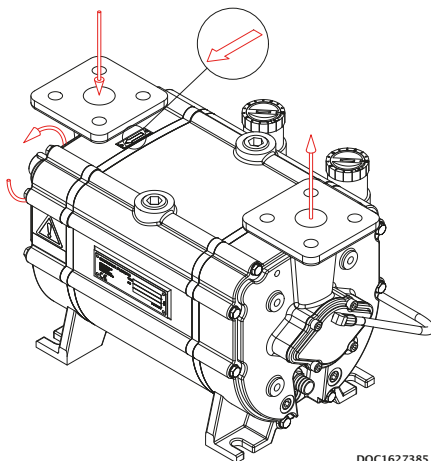

DOC1627385

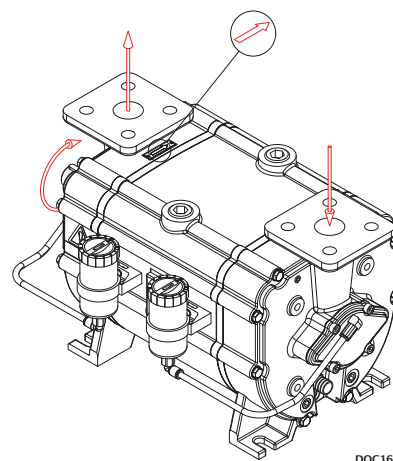

DOC1627431

5 SERVICE, OPERATION, MAINTENANCE AND INSPECTION INTERVALS



A failure to observe the inspection intervals described in table below may result in damage to the pump

Section	Operation	Interval
5.1	Drain liquid separator to remove contaminants	Weekly
5.2	Check grease cartridges (if equipped)	Weekly
5.3	Winterization	When below 0°C
5.4	Lubrication of bearings	Per 500 duty hours
5.5	Inspection and cleaning of service liquid's supply pipe	Monthly
5.6	Inspection and cleaning of internal channels	Monthly

5.1 Draining the liquid separator

While the pump is stopped, the liquid separator must be drained to remove contaminants.

5.2 Check grease cartridges

If the pump is equipped with an automatic lubrication feature. It must be inspected and replaced as needed.

When the pump is commissioned for the first time, the cartridges must be activated by turning the arrow in the clockwise direction.

The cartridge is set to 12, which corresponds to an emptying time of 12 months. The cartridge must be replaced when empty.



It is only allowed to use automatic lubricator of type **LAGD 125/WA2**.

5.3 Winterization

If the pump needs to be used at a temperature below freezing point of the service liquid, it is necessary to protect the liquid from freezing by adding anti freeze liquid.

5.4 Lubrication of bearings



Over-lubrication of bearings may result in bearing damage! Do NOT exceed the amount of grease specified below!

The bearings must be lubricated with grease of type SKF LGWA2, per 500 duty hours. It is recommended to lubricate the bearings while pump is running.

Lubrication interval per 500 duty hours

Drive end (DE)	2 g
Non drive end (NDE)	2 g

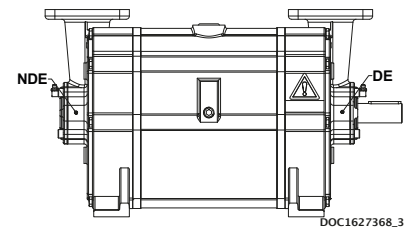

5.5 Inspection and cleaning of service liquid's supply pipe

The pipe connection between the liquid separator and pump must be inspected at least once a month, and any contaminants must be removed.

5.6 Inspection and cleaning of internal channels

The pump is designed with internal water channels for lubrication of the mechanical shaft seals. Remove the plug as illustrated below and clean the channel using a $\varnothing 5$ mm 150 mm long screw driver or similar.

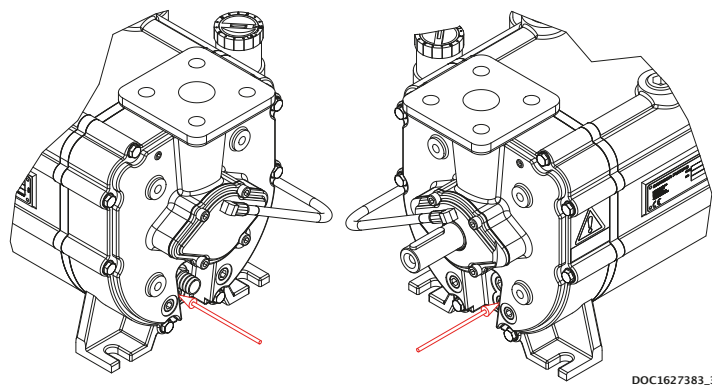

6 TROUBLESHOOTING

Problem	Cause	Effect	Corrective measure
The pump is unable to create a vacuum	<ul style="list-style-type: none"> • Service liquid valve is closed • The pump is not receiving enough service liquid • The temperature of the service liquid is too high 	<ul style="list-style-type: none"> • Reduced output • The pump can become damaged during cavitation 	<ul style="list-style-type: none"> • Check service liquid valve • Check the liquid supply • Stop the pump and wait until the temperature has dropped to a sufficient level, or lower the temperature of the service liquid inlet
The start-up power is too high	<ul style="list-style-type: none"> • Too much service liquid in the pump prior to start-up 	<ul style="list-style-type: none"> • Noise at start-up and possible overload of the power supply 	<ul style="list-style-type: none"> • Check the stop valves in the liquid supply for leakage
Noise during operation	<ul style="list-style-type: none"> • Cavitation 	<ul style="list-style-type: none"> • Severe damage to the pump and potential risk of breakdown 	<ul style="list-style-type: none"> • Increase the suction pressure or lower the temperature of the service liquid
Leakage from the bearing housing's drain holes	<ul style="list-style-type: none"> • Damaged shaft seal 	<ul style="list-style-type: none"> • Bearings may become damaged • Potential risk of explosive gas leak 	<ul style="list-style-type: none"> • Stop the pump and contact the manufacturer

7 SPARE PARTS AND TOOLS

7.1 Marking and identification

The pump is equipped with an identification plate as shown below.



Configuration example:

TM 350 R 0 S S B 1 0 T SD

- Type: ←
- Model: ←
- Rotation: ←
- Rotor type: ←
- Pump housing: ←
- Shell: ←
- Flow plates: ←
- Generation of pump: ←
- Gaskets: ←
- Colour: ←
- Documentation: ←

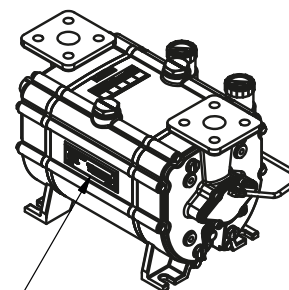

Location of ID plate

DOC107936A

7.2 How to order

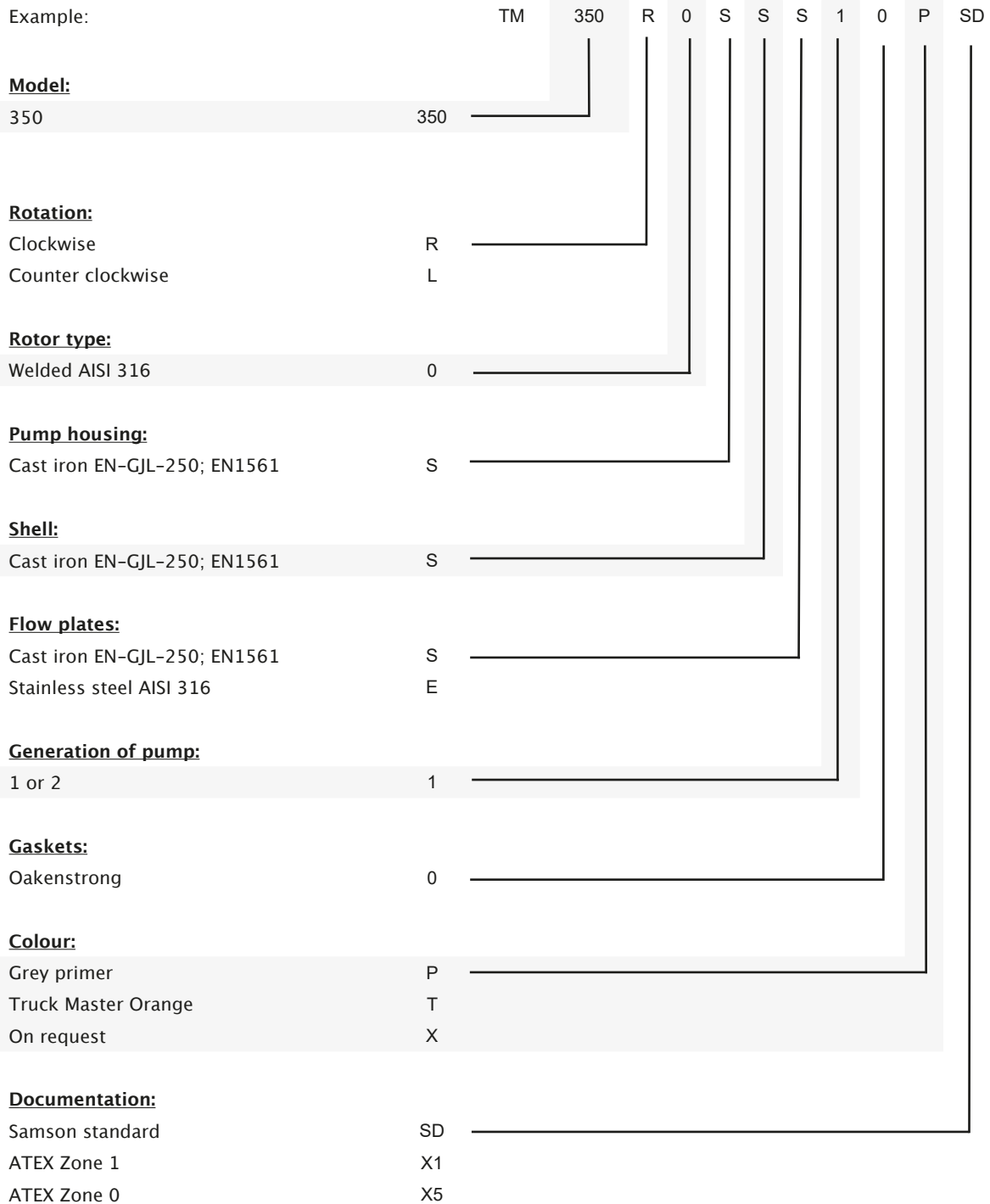

7.3 Spare parts

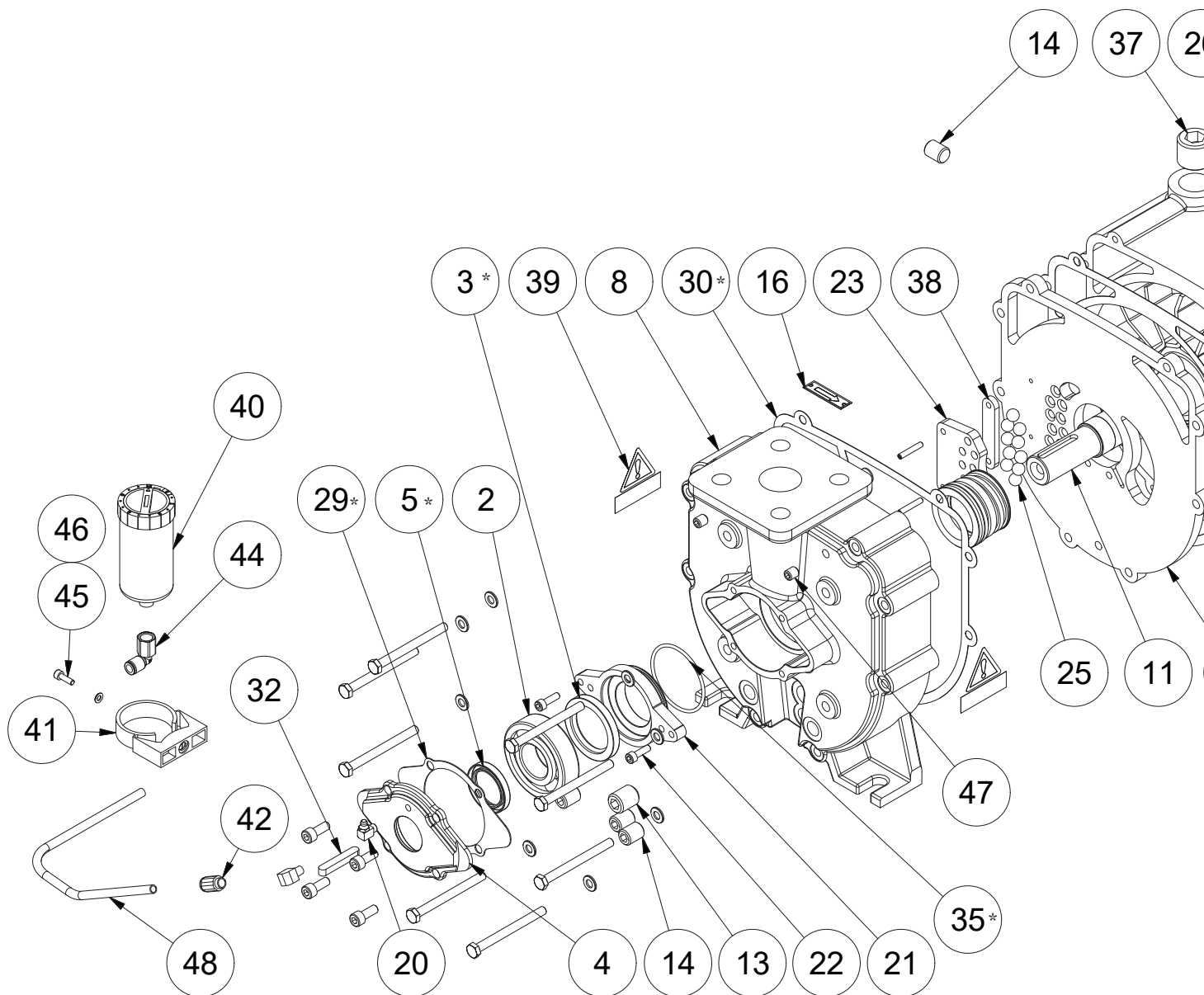

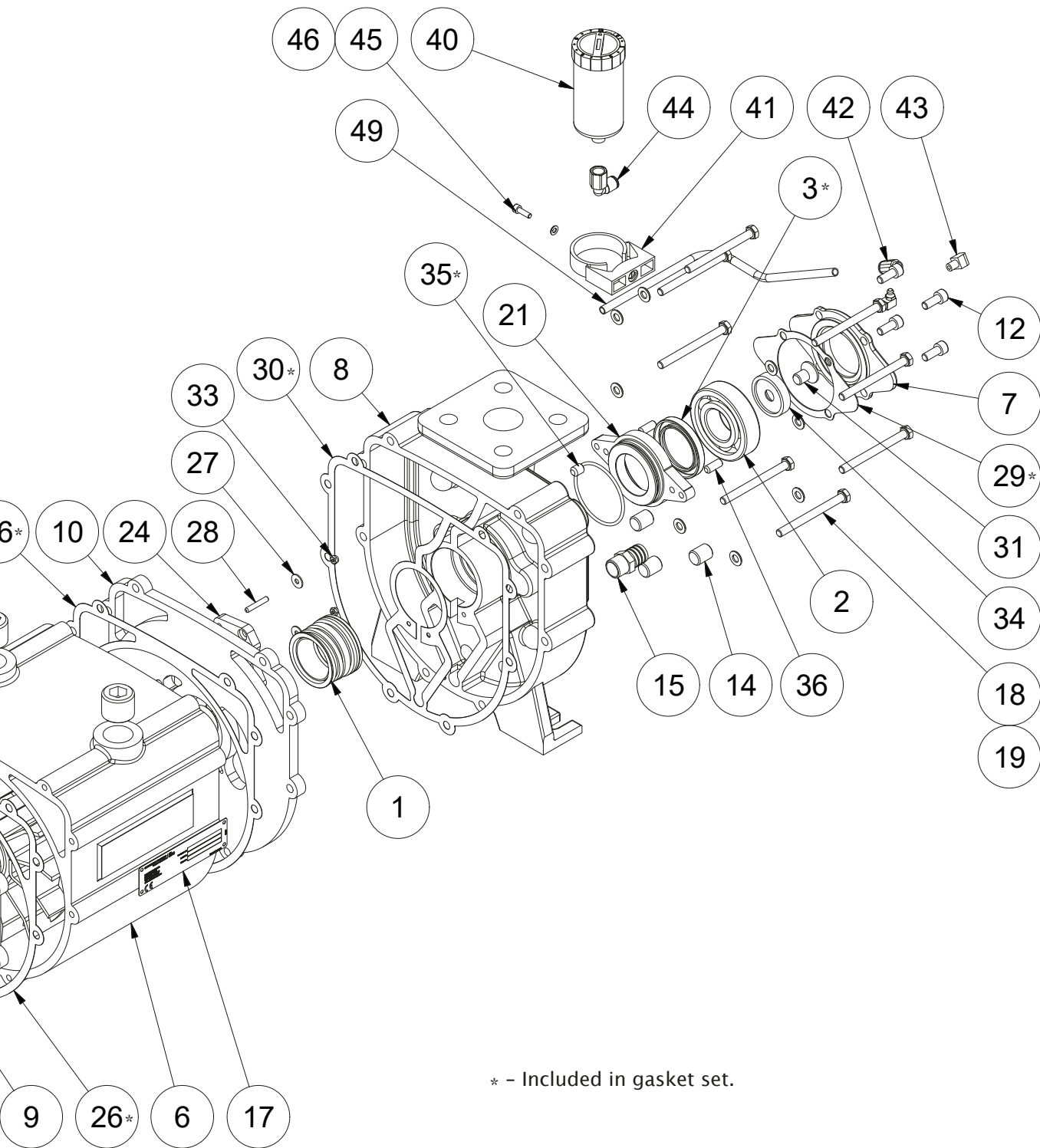

Pos.	Part number	Description	Qty.	Material
1	922000042	Mechanical shaft seal	2	Steel
2	930000078	Ball bearing	2	Steel
3	1600003	Gasket set Truck Master 350	1	-
4	1622072	Bearing cover DE	1	Cast iron
5	1600003	Gasket set Truck Master 350	1	-
6*	1622036	Shell	1	Cast iron
	1622067	Shell	1	Coated
7	1622071	Bearing cover NDE	1	Cast iron
8	1622069	Pump housing	2	Cast iron
9*	1622038	Flow plate	1	Cast iron
	1622019	Flow plate	1	Stainless steel
10*	1622040	Flow plate	1	Cast iron
	1622020	Flow plate	1	Stainless steel
11*	1622107	Rotor R	1	Stainless steel
	1622110	Rotor L	1	Stainless steel
12	910300024	Allen screw	8	Steel
13	910300184	Plug	1	Brass
14	910300188	Plug	7	Brass
15	925000246	Hose nipple	1	Brass
16	-	Direction arrow	1	Aluminum
17	-	Identification plate	1	Stainless steel
18	910000020	Bolt	16	Steel
19	910100007	Washer	16	Steel
20*	915000197	Grease nipple	2	Steel
21	1622074	Adjustment plate	2	Cast iron
22	910300447	Allen screw	6	Stainless steel
23	1622024	Ball guide	1	Plastic
24	1622025	Ball guide	1	Plastic
25	962000047	Valve Ball	20	Plastic
26	1600003	Gasket set Truck Master 350	1	-
27	910100149	Washer	4	Stainless steel
28	910300446	Socket set screw	4	Stainless steel
29	1600003	Gasket set Truck Master 350	1	-
30	1600003	Gasket set Truck Master 350	1	-
31	910300459	Allen screw	1	Steel
32	915000210	Parallel key	1	Steel
33	910200107	Lock nut	4	Stainless steel
34	1622075	Washer	1	Stainless steel

* -See section 7.1 for identification of pump.

**-Optional. Not equipped as standard.

Pos.	Part number	Description	Qty.	Material
35	1600003	Gasket set Truck Master 350	1	-
36	910300125	Socket set screw	2	Steel
37	910300182	Plug	2	Stainless steel
38	1622026	Spacer for ball guide	2	Stainless steel
39	1624020	Sticker Warning!	2	Plastic foil
40**	915000225	Automatic lubricator LAGD 125/WA2	2	Plastic / grease
41**	915000232	Clamp for automatic lubricator	2	Plastic
42**	944600239	Push-in nipple	2	Brass
43**	944600173	Elbow	2	Brass
44**	944600240	Elbow	2	Brass
45**	910300221	Allen screw	2	Steel
46**	910100002	Washer	2	Steel
47	910300281	Plug	4	Steel
48**	915000217	Plastic pipe	0,3 m	Plastic
49**	915000217	Plastic pipe	0,3 m	Plastic

* -See section 7.1 for identification of pump.

**-Optional. Not equipped as standard.

7.4 Adaptor

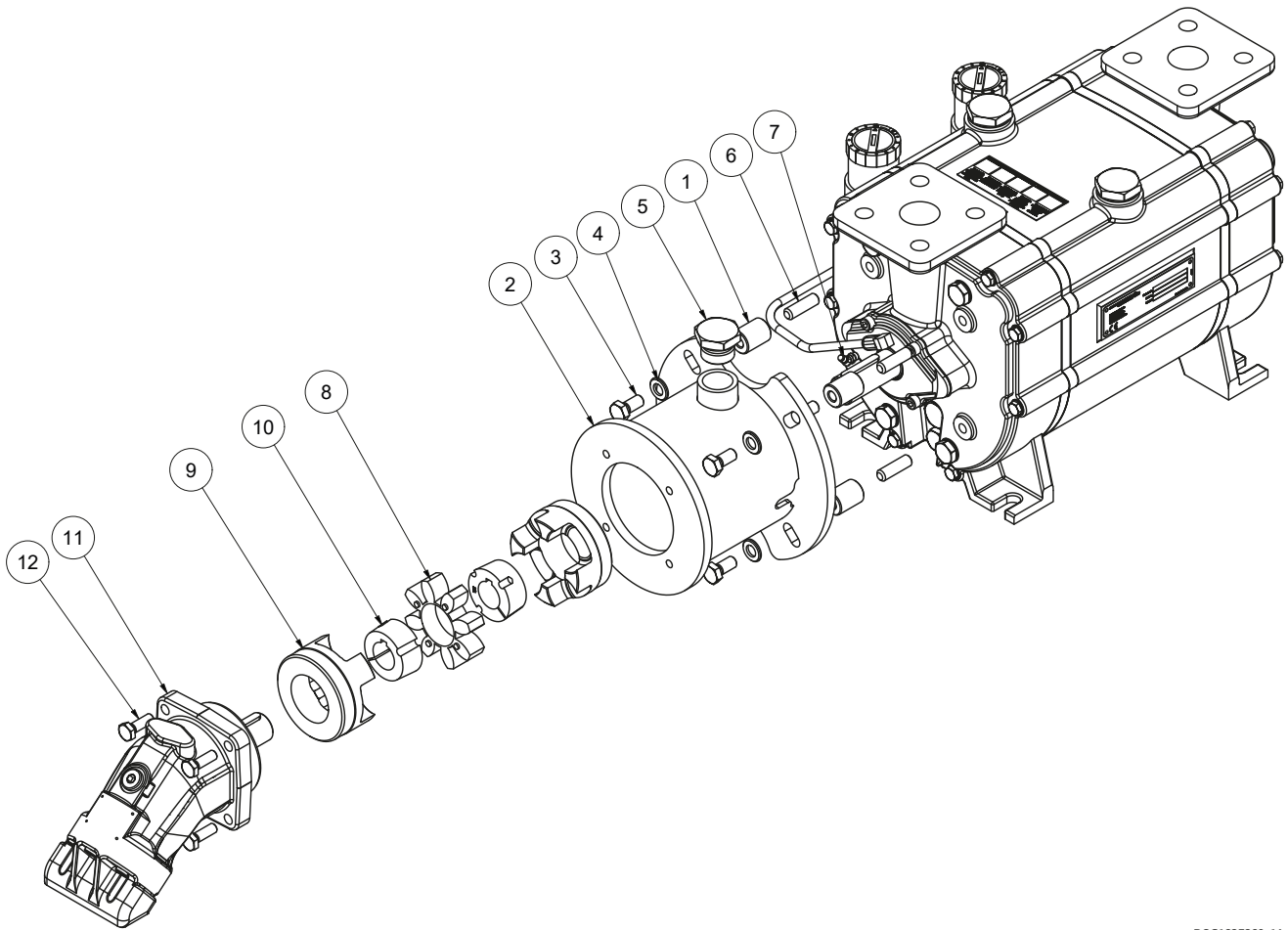

DOC1627369_1A

Pos.	Part number	Description	Qty.	Material
1	1613110	Bush	4	Stainless Steel AISI 316
2	1634738	Adaptor for hydraulic motor	1	Steel S235JR
3	910000364	M12x25 set screw	4	Stainless Steel DIN 933
4	910100013	M12 washer	4	Stainless Steel
5	1634812	Plug 1"	1	Stainless Steel
6	910300445	M12x40 socket set screw	4	Steel DIN 916
7	915000054	Grease nipple	1	Steel VFZ
8	932400120	Coupling, Element 42/55	1	Rubber
9	932400121	Coupling hub 42/55	2	Cast iron
10	932300029	Taper-Lock Bush 1610-30	2	Cast iron
11	944000084	Hydraulic motor 032 ISO	1	Cast iron
12	910000563	M10x30 screw	4	Stainless Steel DIN 933

7.5 Gasket set



DOC11592

Pos.	Part number	Description	Qty.	Material
3	922200051	Radial shaft seal 45x65x8	2	Rubber / Steel
5	922200022	Radial shaft seal 35x50x7	1	Rubber / Steel
	922200020	Radial shaft seal 35x47x7 (<2012)	1	Rubber / Steel
26	1622027	Gasket for shell / flow plate 0,4 mm	2	Paper
	1622066	Gasket for shell / flow plate 0,8 mm	2	Paper
29	1622076	Gasket for bearing cover 1 mm	2	Rubber
	1622029	Gasket for bearing cover 0,4 mm (<2012)	2	Paper
30	1622028	Gasket for pump housing / flow plate 0,4 mm	2	Paper
35	922100361	O-ring Ø64,50x3,00	2	Rubber

See spare parts drawing (DOC1627368_2) for positions.

7.6 Special tool set

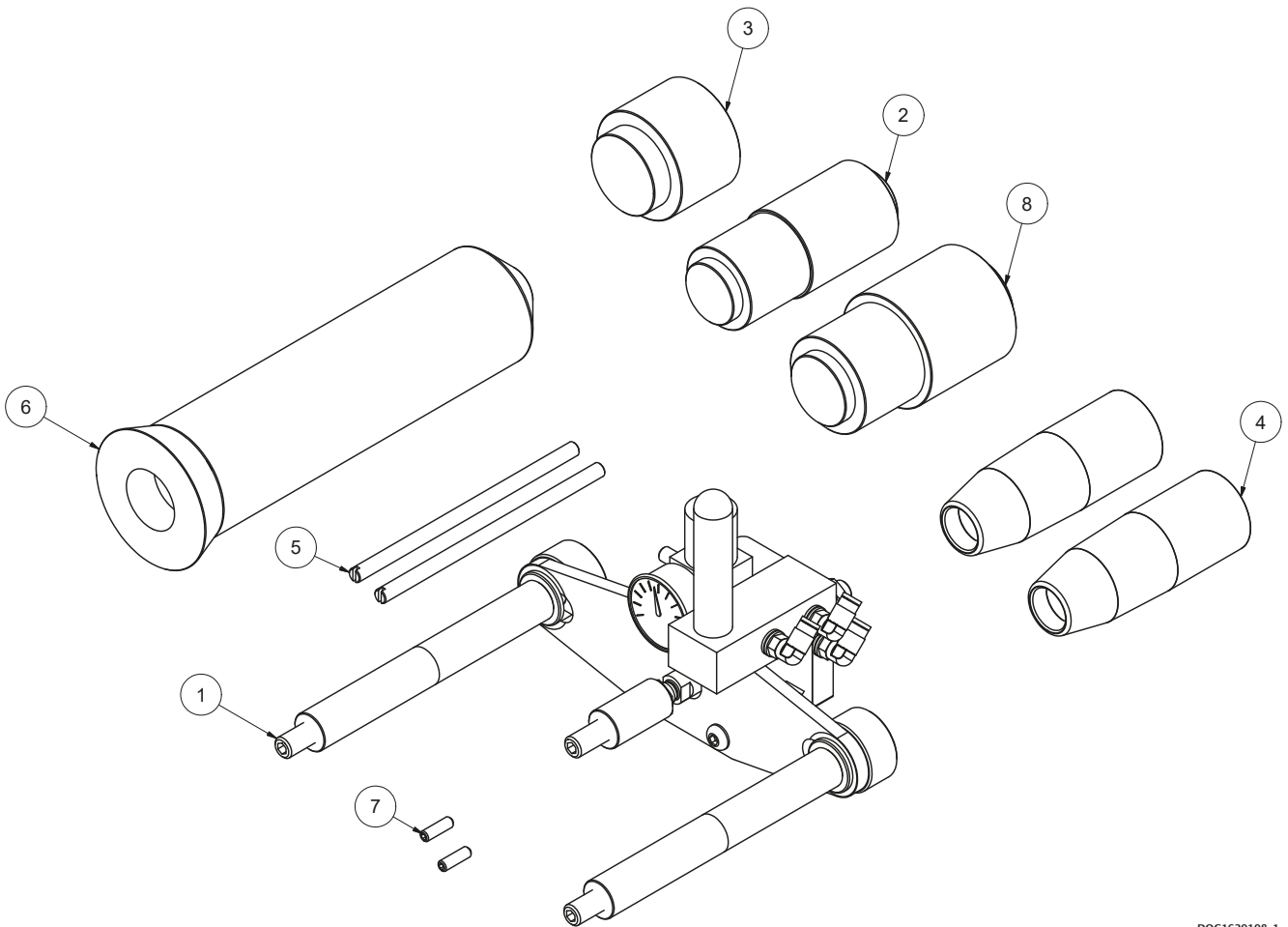

DOC1629198_1

Pos.	Part number	Description	Qty.	Material
1	1629136	Bearing tool	1	Steel
2	1629195	Mandrel radial shaft seal Ø35	1	Plastic
3	1629197	Mandrel mechanical shaft ring	1	Plastic
4	1629098	Assembly bush	2	Plastic
5	1629194	Guide pin M8	2	Steel
6	1629192	Bearing mounting tool	1	Plastic
7	910300428	Socket set screw	2	Steel
8	1629196	Mandrel radial shaft seal Ø40 + Ø45	1	Plastic

Notes:

Notes:

SAMSON PUMPS

Samson Pumps is the only company in the world to specialise exclusively in liquid ring vacuum pumps. Samson pumps are made in Denmark and used around the globe. We offer worldwide delivery, and we export to more than 80 countries around the world.

For over 40 years, our name has been synonymous with the strongest pumps for vacuum trucks and tankers. We constantly adapt our products to meet the changing needs of our customers. Today, it is not enough to simply produce a pump. Products must be refined so the customer can concentrate on what they do best. We therefore offer a wide range of standardised components that allow our customers to build vacuum systems without the need for specialist in-house expertise.

Strength and durability are our hallmarks! We have often heard from customers that our pumps are working in many years, and in most cases without the need for maintenance or repair. This emboldens us to say that we have the strongest program of pumps on the market.