

INSTRUCTION MANUAL

LIQUID RING PUMP



OCEAN MASTER® 250

INSTRUCTION MANUAL FOR SAMSON LIQUID RING PUMP
OCEAN MASTER 250

-
- Technical data
 - Design of a system
 - Installation and start-up
 - Service
 - Troubleshooting
 - Spare parts

CONTENTS

1	Introduction	4
1.1	Declaration of conformity.....	4
1.2	Explanation of warning symbols.....	5
1.3	Field of application.....	5
1.4	Disposal.....	5
2	Technical data.....	6
2.1	Dimensions.....	6
2.2	Specifications.....	7
2.3	Power consumption and output.....	8
2.3.1	Performance	8
2.3.2	Consumption	9
2.4	Handling and transport	10
2.5	Pump storage and draining procedure.....	11
3	Design of a system	12
3.1	Piping	13
3.2	Service liquid adjustment	13
3.3	Service liquid pump.....	13
3.4	Pump performance.....	14
3.5	Pressure drop.....	15
3.6	Service liquid requirement.....	16
4	Installation and start-up.....	17
4.1	Securing the pump.....	17
4.2	Connections to the pump.....	17
4.3	Connecting the service liquid	17
4.4	Transmission	17
4.5	Prior to start-up.....	18
4.6	Direction of rotation	18
5	Service, operation, maintenance and inspection intervals.....	19
5.1	Check grease cartridges	19
5.2	Winterization.....	19
5.3	Lubrication of bearings	20
5.4	Inspection and cleaning of service liquid's supply pipe.....	20
5.5	Inspection and cleaning of internal channels	20

6	Troubleshooting	21
7	Spare parts and tools.....	22
7.1	Marking and identification.....	22
7.2	How to order.....	23
7.3	Spare parts.....	24
7.4	Adaptor.....	28
7.5	Gasket set.....	29
7.6	Special tool set.....	30

1 INTRODUCTION

1.1 Declaration of conformity

SAMSON PUMPS

Declaration of Conformity

Annex IIA

Samson Pumps A/S
Petersmindevej 21
DK-8800 Viborg

Hereby declares that the following products:

Liquid ring pump
Ocean Master 250, Ocean Master 450, Ocean Master 500,
Ocean Master 700, Ocean Master 1000, Ocean Master SVF27

Conforms to the directive:

Machinery Directive 2006/42/EC

I hereby declare that the liquid ring pumps are in conformity with the following harmonized standards:

DS/EN ISO 12100:2011	Safety of machinery – General principles for design – Risk assessment and risk reduction
DS/EN 1012-2 + A1:2009	Compressors and Pumps – Safety requirements – Part 2: Vacuum pumps

The standards above only apply to the extent that it is relevant for the purpose of the pump. The product must not be used before the complete system, which it must be incorporated in, has been conformity assessed and found to comply with all relevant health and safety requirements of 2006/42/EC and other relevant directives. The product must be included in the overall risk assessment.

Viborg, 05.12.2019



Jan S. Christiansen – Manager, Technical dept.

DOC4045A

E-Mail	info@samson-pumps.com	Samson Pumps A/S	Petersmindevej 21
Web	www.samson-pumps.com	Phone +45 87 50 95 70	DK-8800 Viborg

1.2 Explanation of warning symbols

Important technical and safety instructions are shown by symbols. If the instructions are not performed correctly, it can lead to personnel injuries or incorrect function of the pump.



To be used with all safety instructions that must be followed. A failure to follow the instructions may result in injuries and/or incorrect machine operation

1.3 Field of application



Inlet of foreign objects can damage the pump



The pump is designed exclusively to pump gases, including atmospheric air



WARNING!
Avoid cavitation of the pump! For further information, see instruction manual for the Samson Pumps vacuum limiter

It must be ensured that the inlet gas cannot react with the service liquid and create aggressive bonds that break down the pump's components.

For other operating data, see specifications.

- The pump must only be used with media that is not aggressive to the pump's materials. See section 7 for components and materials.

1.4 Disposal

Samson's liquid ring pump is manufactured so that most of the device can be reused/recycled.

Samson Pumps offer users of the company's pumps the option of returning used pumps to be restored or scrapped.

Alternatively, the pump must be taken apart and sorted into its separate components, by the customer (see section 7 for the pump's material).

These components must be disposed of in accordance with national regulations.

2 TECHNICAL DATA

2.1 Dimensions

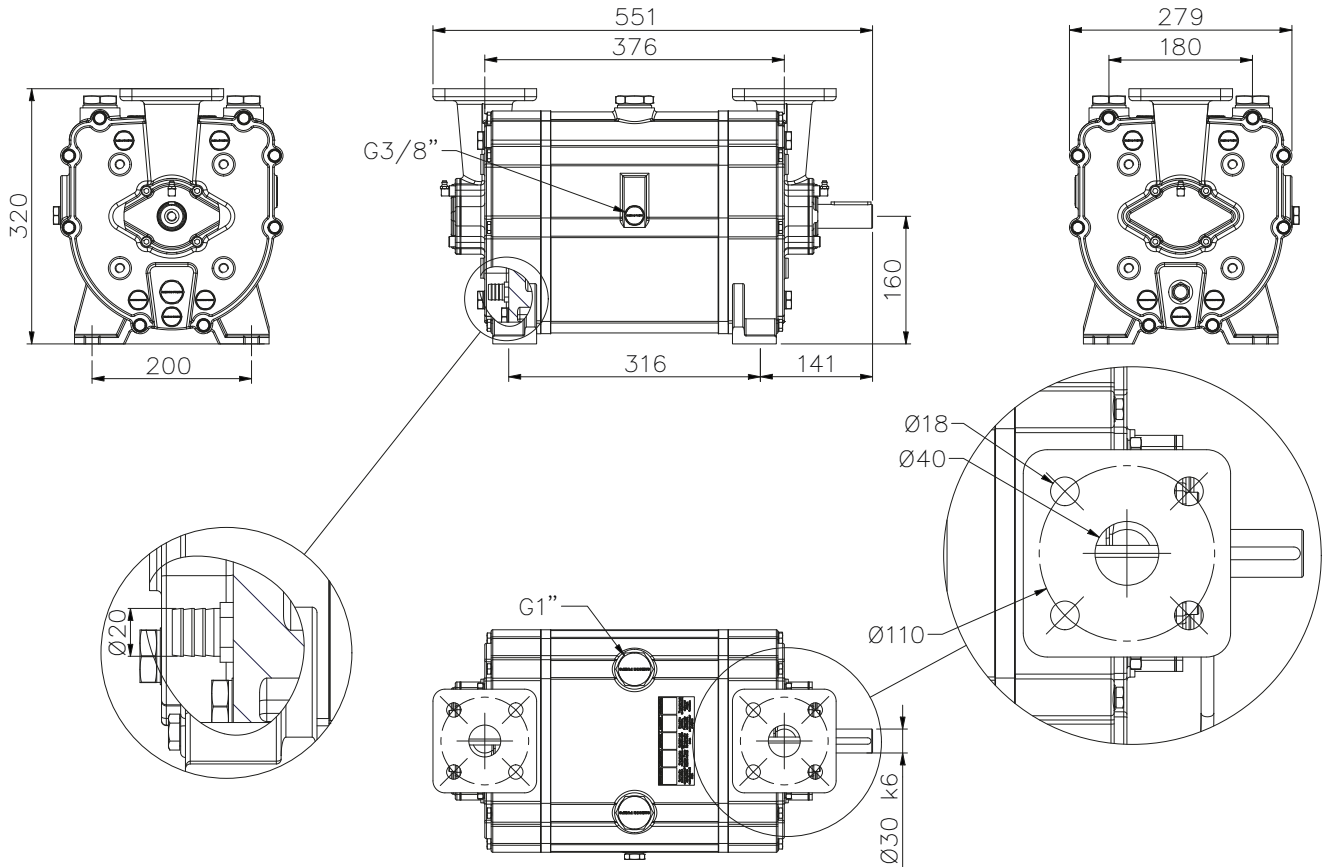

DOC16273878

2.2 Specifications



A failure to meet these specifications may result in damage to the pump

Description		Minimum	Maximum
Ambient temperature, operation	Below 0°C – see chapter 5.3	-20°C	55°C
Ambient temperature, storage		-20°C	55°C
Humidity		-	100%
Intake temperature, suction side		-	60°C
Intake temperature, service liquid		-	60°C
Service liquid pipe connection, dimension		½"	-
Service liquid pipe connection, length		-	6 m
Noise level		-	70 dB(A)
Water volume		-	7 L
Maximum radial load on drive shaft		-	1500 N
Revolutions		1200 rpm	1800 rpm
Pressure		150 mbar abs.	2 bar(g)
Lubricating grease	Type of grease	SKF LGWA2	
	Automatic lubrication	SKF LAGD 125/WA2	
Weight		87 kg	

2.3 Power consumption and output

2.3.1 Performance

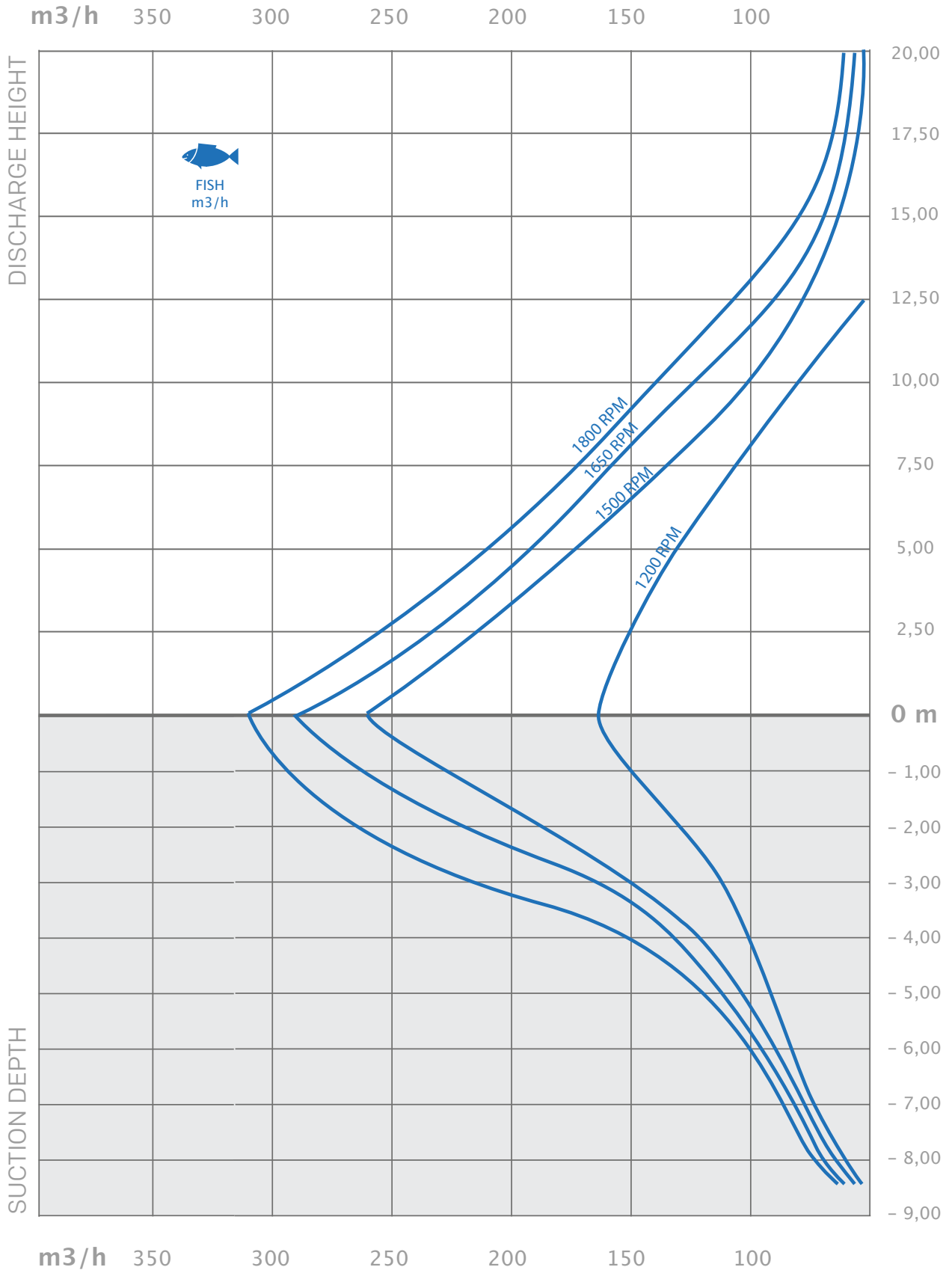

DOC11585A

2.3.2 Consumption

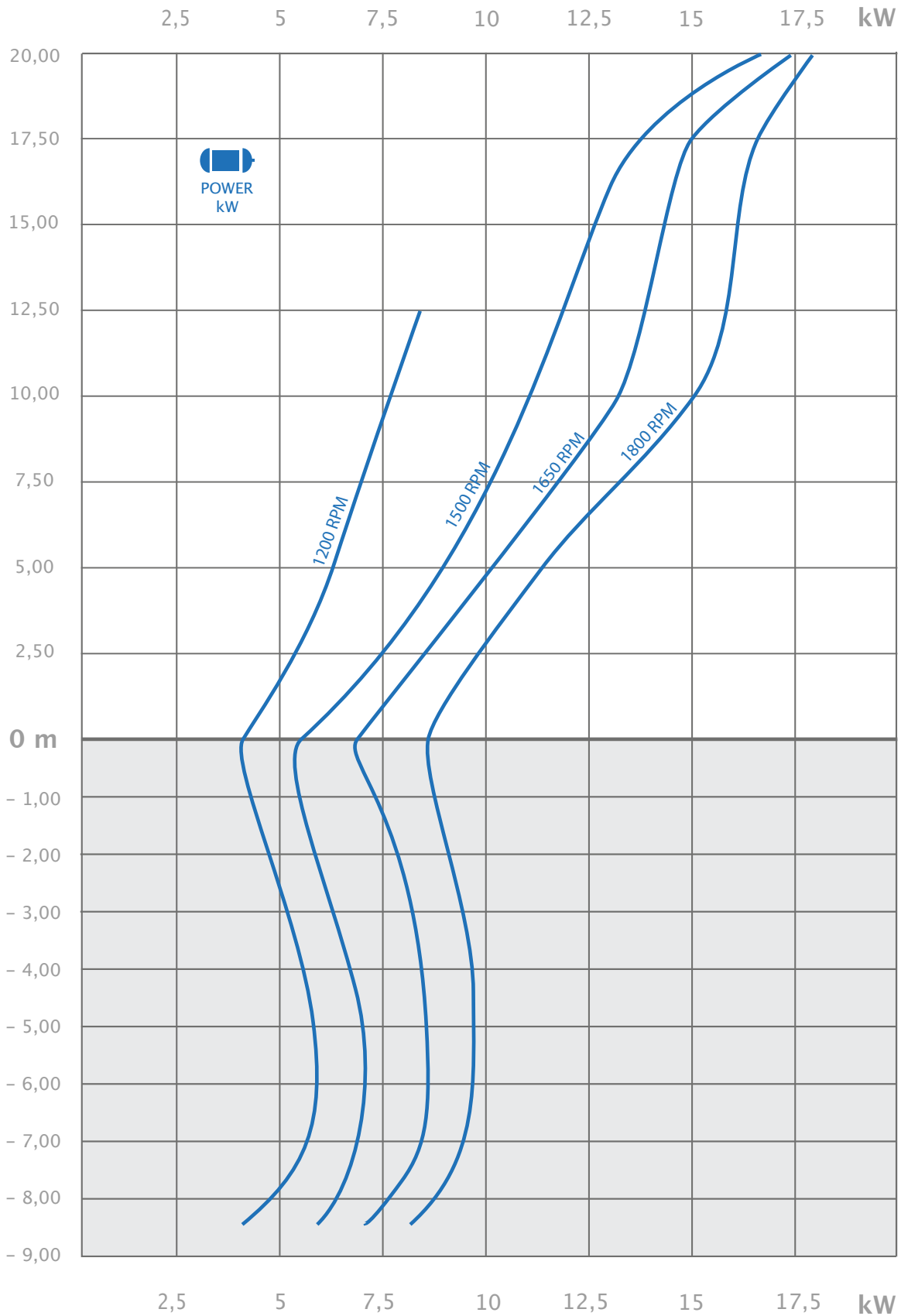

DOC11585A

2.4 Handling and transport



The pump must not be used if it is damaged or the identification plate is missing

The pump must be transported in such way that it is not exposed to vibrations and impacts that can overload the bearings.

The pump must be inspected for damages upon delivery. If the pump is damaged, it must not be used and the damage must be reported to the manufacturer.

Ensure that the pump's identification plate is intact and that the marking of the pump corresponds to its use.

The pump must only be handled using approved lifting eyes, in accordance with nationally applicable regulations and only in a vertical motion.

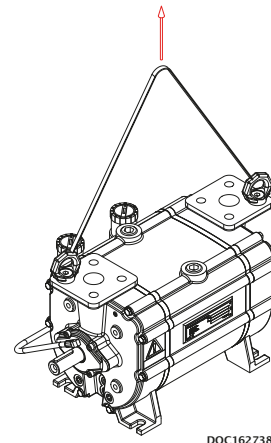

The pump can be transported in the following ways:

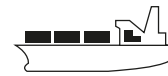

2.5 Pump storage and draining procedure



A failure to comply with the requirements for storing the pump may result in internal damage to the device



If the temperature is below freezing point of the service liquid, it could damage the pump. Under these conditions, the pump must be drained completely.



All plugs and protective covers must be fitted during storage.

The pump's service liquid is drained on delivery, and the pump can be immediately stored in accordance with the technical specifications.

After operation, the pump can be stored for 30 days without further action.

If the pump remains out of operation for a longer period of time after use, its service liquid must be drained, and the liquid supply to the pump must be shut off.

When emptying the pump, it is important that all chambers inside the pump are emptied.

The pump can be fitted with valves in the draining connections. See below.

After use with sea water it is recommended to drain and flush the pump with fresh water.

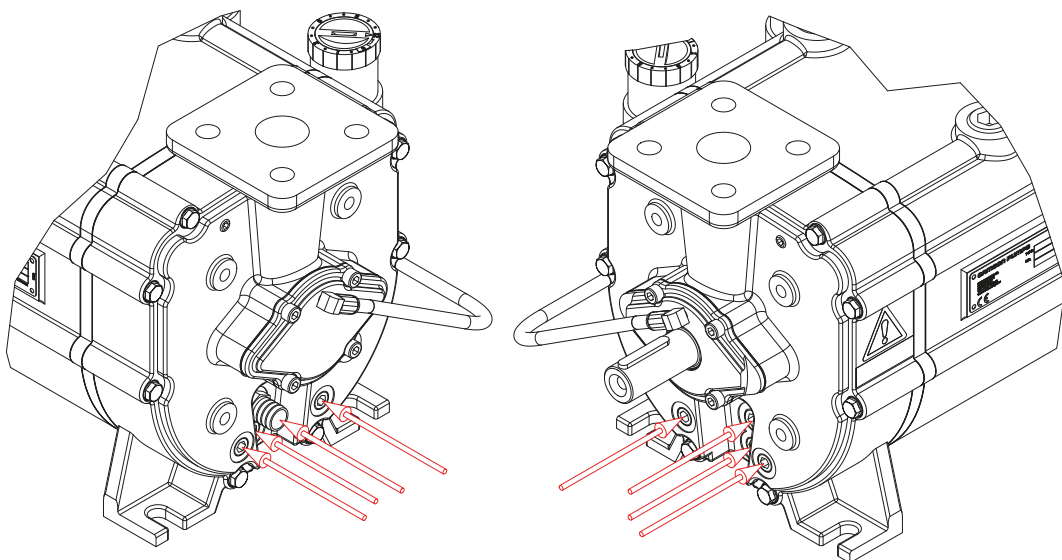

DOC1627389

3 DESIGN OF A SYSTEM

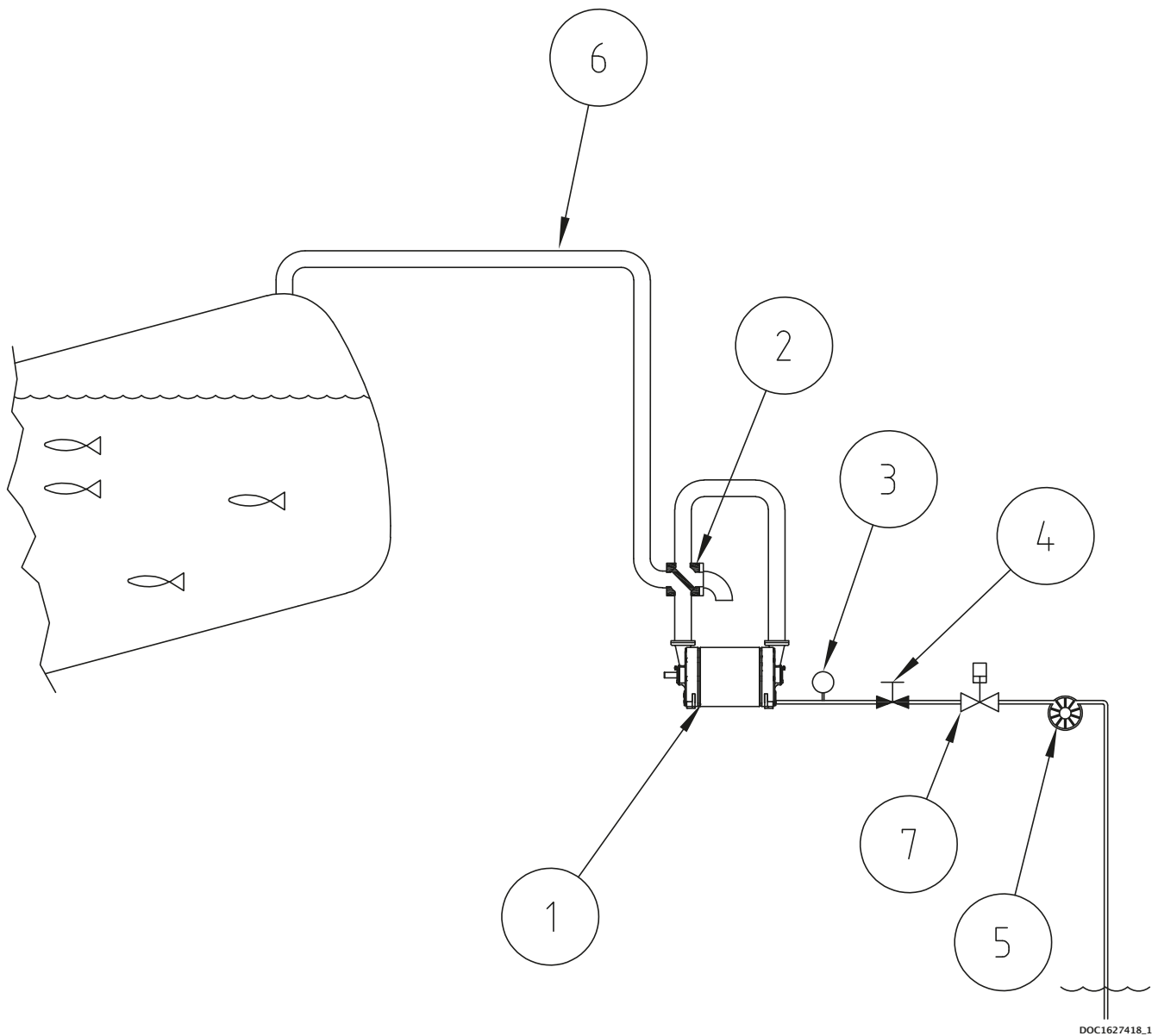

DOC1627418_1

Pos.	Description
1	Liquid ring pump
2	4-way valve
3	Pressure gauge
4	Regulating valve
5	Water pump
6	Pipe connection - Critical pipe
7	Stop valve

3.1 Piping

In a fish handling system, where the pump is working without liquid separator, the piping can be critical. The pipe pos 6 will be a combination of a discharge and a suction pipe and the design of this pipe is very important.

Figure below shows a standard setup. When the pump is discharging, the tank pipe pos 6 will carry a mixture of air and water, which is the sealing water supplied to the pump. When the 4 way valve pos 2 change position this pipe becomes the suction pipe and water that is in the pipe will enter the pump. In normal situation a small vibration will follow when the pump is injected with water on the suction side. It is important to keep a high velocity $> 30 \text{ m/s}$ in this pipe and design it as short as possible without "water traps". The velocity can be calculated based on the nominal flow and the pipe diameter. Another and safer solution is to place the 4 way valve closer to the fish tank as illustrated below.

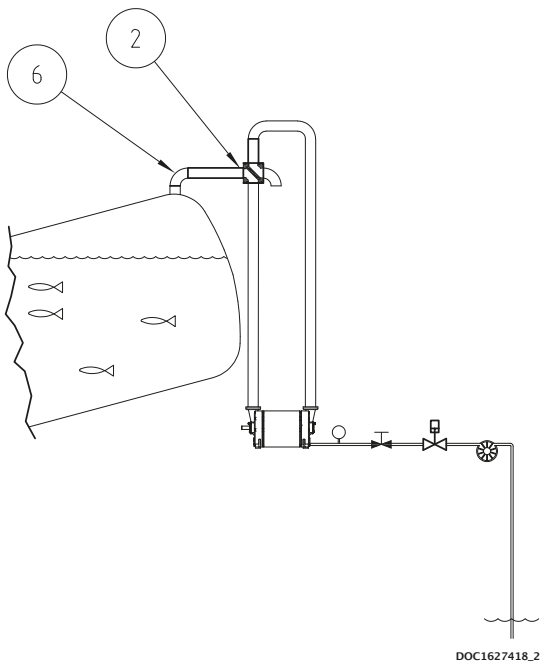

3.2 Service liquid adjustment

In order to get the correct water pressure to the pump it is recommended to build the supply line as illustrated below. For correct service liquid supply, the neutral pressure needs to be adjusted to between 0,6 and 0,8 bar(g) when the pump is running unloaded.

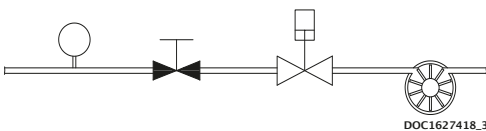

3.3 Service liquid pump

The water pump must be able to have a flow on 3000 l/h at a pressure at 1 bar(g) in order to get the full performance of the liquid ring pump.

3.4 Pump performance

The pump performance can easily be found using the performance curves.

- Plot in the lifting height and add the calculated pressure drop in meter water column.
- Follow a horizontal line till you meet the performance curve.
- Go vertical down and read the performance.

For practical design it is important that the speed in the pipe system etc. is verified against a fish handling perspective.

Note: 1 meter water column = 0,1 bar = 100 mbar

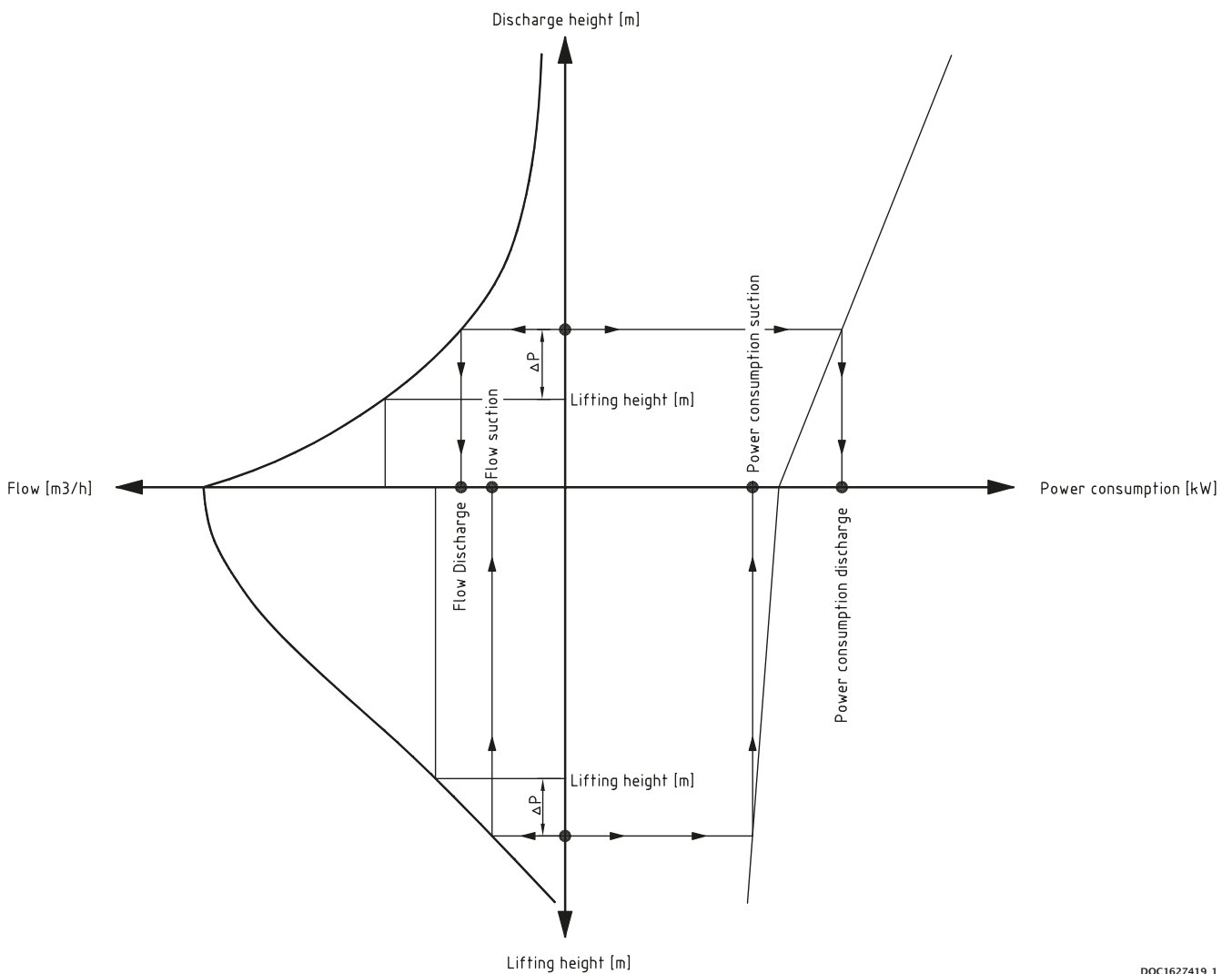

DOC1627419_1

3.5 Pressure drop

The pressure drop in the system depends on the flow and on the other side the flow will depend on the pressure drop.

It is a mathematical iteration process, therefore in practice we need to start the calculation with a guess. As a start value for the flow it will be recommended to use the flow corresponding to the static lift + 1 meter corresponding to 0,1 bar or 100 mbar.

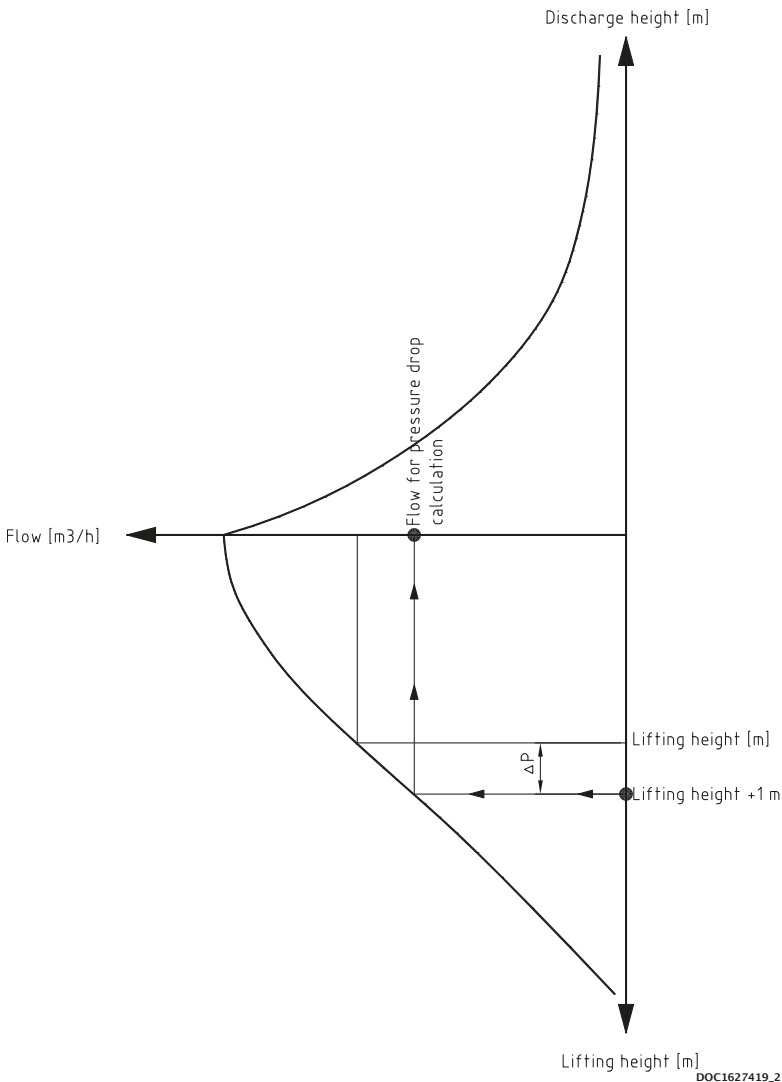

It is possible to calculate the pressure drop manually, but there is a lot of free programs for download. Use the system data to evaluate the pressure drop used as start value. The calculated value can be used to find out if the start value is too low or too high.

Example

If the calculated pressure drop is far below the start value (100mbar) make a new calculation with the flow based on for example 50 mbar. Start with the static pressure + 50 mbar and find the flow from the curve.

If the calculated pressure drop is far above the start value (100 mbar), make a new calculation with the flow based on for example 200 mbar. Start with the static pressure + 200 mbar and find the flow from the curve.

NOTE: Pressure drop above 100 mbar indicates that your pipe diameter is too small for the pump you are using.

3.6 Service liquid requirement

If sea water is used as sealing water, it is recommended to flush the pump with fresh water after use and drain the pump afterwards.

Before the pump is started again, remember to fill the pump to about shaft height before start up. Otherwise the pump will be started with dry run of the mechanical shaft seals, which will shorten the lifetime.

A drain valve mounted in the pump will help to identify the correct level of water. See below.

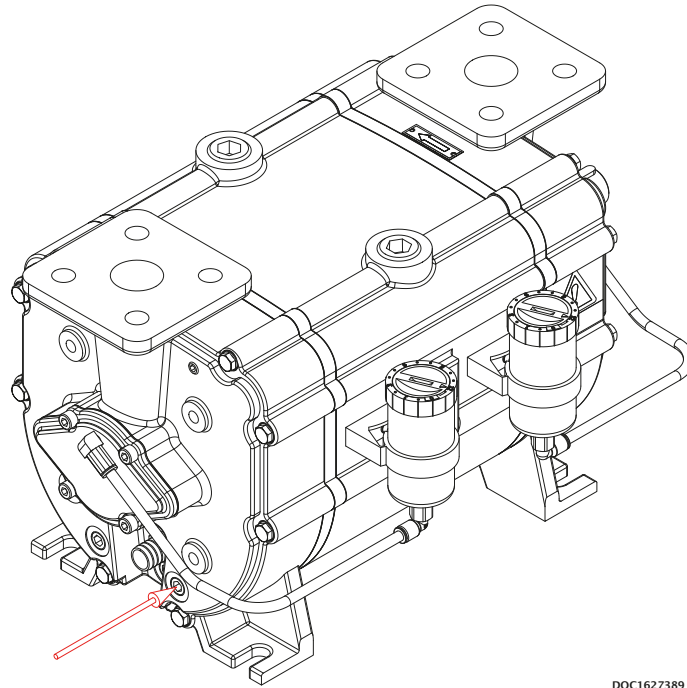

DOC1627389_2

4 INSTALLATION AND START-UP

4.1 Securing the pump



Installation requirements must be observed, otherwise there is a risk of damage

The pump must be installed on a stable foundation, which must be level and stable, so that the pump is not twisted or exposed to a profile distortion.

The pump must be installed with M12 bolts on all four legs, which must be tightened to 60 Nm (A).

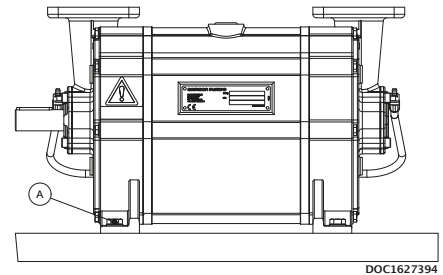

4.2 Connections to the pump



- Check for foreign objects in the pump and physical damage on pump
- Gaskets to be handled with highest degree of caution
- Gasket and sealing surfaces must be cleaned before assembly

Immediate before connecting the pipes, remove protective covers. Connection of the pump's suction and pressure pipe connections must be made with a gasket in between (C).

The M12 bolts must be tightened with 60 Nm (B).

In order to prevent tensions in the pump, the pipe connections (A) must be tensionless while tightening the bolts.

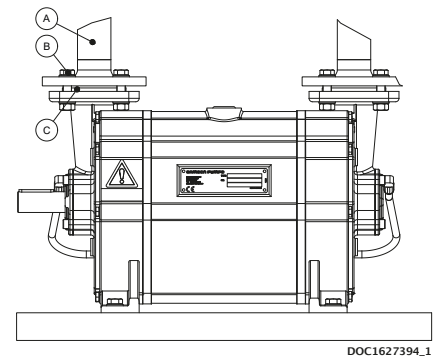

4.3 Connecting the service liquid

The service liquid must be connected to the pump at the hose connection, see illustration.

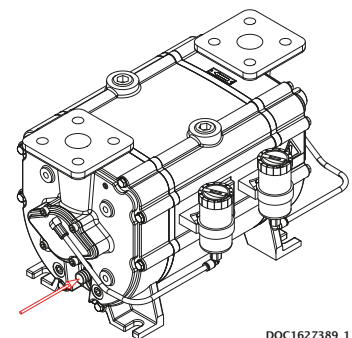

4.4 Transmission

The pump can be connected direct or through belt transmission. For belt transmission, it must be ensured that the permissible radial force is not exceeded. See specifications.

4.5 Prior to start-up



- Do not start the pump without service liquid, as this will damage the mechanical shaft seals
- Do not start the pump if it is completely filled with service liquid
- Do not start the pump before the grease cartridges have been activated, as this can damage the pump (if equipped)
- Stop the pump immediately if the rotational direction does not correspond to the directional arrow
- A failure to follow the above guidelines may result in damage to the pump

Activating the grease cartridges (Accessories)

Turn the handle in NDE clockwise to position 12.
Turn the handle in DE clockwise to position 12.
The pump has been lubricated from factory and is ready to start.

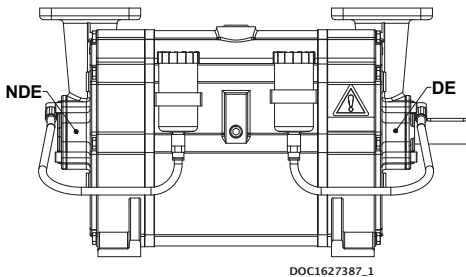

4.6 Direction of rotation

Check the direction of rotation by briefly starting the pump.

The direction of rotation of the rotor must correspond to the direction arrow!

Below left, a right-side pump is shown which has a clockwise direction of rotation (CW)

Below right, a left-side pump is shown which has a counter-clockwise direction of rotation (CCW)

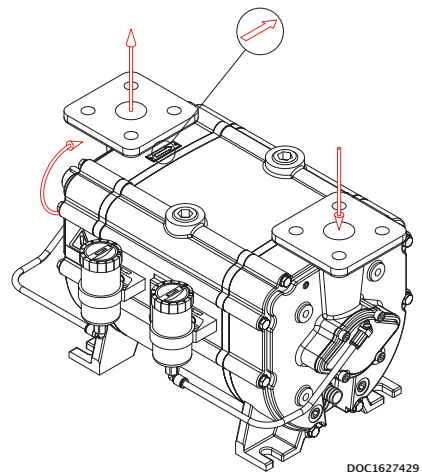
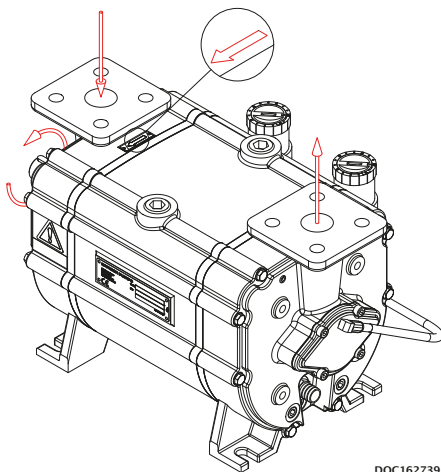

5 SERVICE, OPERATION, MAINTENANCE AND INSPECTION INTERVALS



A failure to observe the inspection intervals described in table below may result in damage to the pump

Section	Operation	Interval
5.1	Check grease cartridges (if equipped)	Weekly
5.2	Winterization	When below 0°C
5.3	Lubrication of bearings	Per 500 duty hours
5.4	Inspection and cleaning of service liquid's supply pipe	Monthly
5.5	Inspection and cleaning of internal channels	Monthly

5.1 Check grease cartridges

If the pump is equipped with an automatic lubrication feature. It must be inspected and replaced as needed.

When the pump is commissioned for the first time, the cartridges must be activated by turning the arrow in the clockwise direction.

The cartridge is set to 12, which corresponds to an emptying time of 12 months. The cartridge must be replaced when empty.

It is only allowed to use automatic lubricator of type **LAGD 125/WA2**.



5.2 Winterization

If the pump needs to be used at a temperature below freezing point of the service liquid, it is necessary to protect the liquid from freezing by adding anti freeze liquid.

5.3 Lubrication of bearings



Over-lubrication of bearings may result in bearing damage! Do NOT exceed the amount of grease specified below!

The bearings must be lubricated with grease of type SKF LGWA2, per 500 duty hours. It is recommended to lubricate the bearings while pump is running.

Lubrication interval per 500 duty hours

Drive end (DE)	3 g
Non drive end (NDE)	3 g

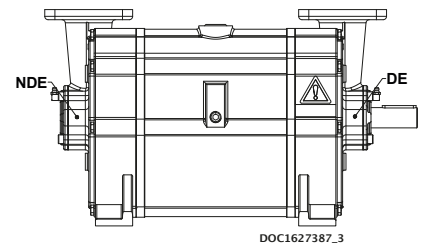

5.4 Inspection and cleaning of service liquid's supply pipe

The pipe connection between the liquid separator and pump must be inspected at least once a month, and any contaminants must be removed.

5.5 Inspection and cleaning of internal channels

The pump is designed with internal water channels for lubrication of the mechanical shaft seals. Remove the plug as illustrated below and clean the channel using a $\varnothing 5$ mm 150 mm long screw driver or similar.

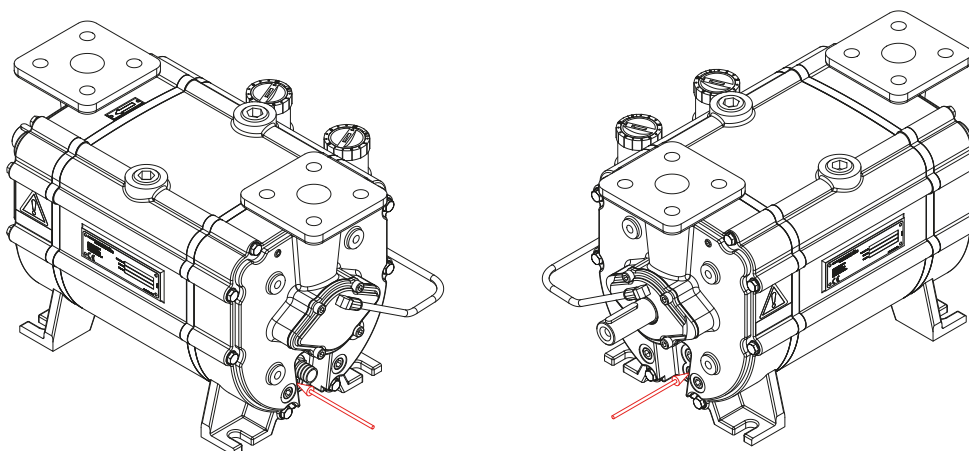

DOC1627389_3

6 TROUBLESHOOTING

Problem	Cause	Effect	Corrective measure
The pump is unable to create a vacuum	<ul style="list-style-type: none"> • Service liquid valve is closed • The pump is not receiving enough service liquid • The temperature of the service liquid is too high 	<ul style="list-style-type: none"> • Reduced output • The pump can become damaged during cavitation 	<ul style="list-style-type: none"> • Check service liquid valve • Check the liquid supply • Stop the pump and wait until the temperature has dropped to a sufficient level, or lower the temperature of the service liquid inlet
The start-up power is too high	<ul style="list-style-type: none"> • Too much service liquid in the pump prior to start-up 	<ul style="list-style-type: none"> • Noise at start-up and possible overload of the power supply 	<ul style="list-style-type: none"> • Check the stop valves in the liquid supply for leakage
Noise during operation	<ul style="list-style-type: none"> • Cavitation • Too much water in the pipe system when switching from pressure to vacuum 	<ul style="list-style-type: none"> • Severe damage to the pump and potential risk of breakdown 	<ul style="list-style-type: none"> • Adjust the service liquid pressure • Redesign the pipe system (critical pipe)
Leakage from the bearing housing's drain holes	<ul style="list-style-type: none"> • Damaged shaft seal 	<ul style="list-style-type: none"> • Bearings may become damaged • Potential risk of explosive gas leak 	<ul style="list-style-type: none"> • Stop the pump and contact the manufacturer

7 SPARE PARTS AND TOOLS

7.1 Marking and identification

The pump is equipped with an identification plate as shown below.



Configuration example:

OM 250 R 0 S S B 1 0 S SD

- Type: ←
- Model: ←
- Rotation: ←
- Rotor type: ←
- Pump housing: ←
- Shell: ←
- Flow plates: ←
- Generation of pump: ←
- Gaskets: ←
- Colour: ←
- Documentation: ←

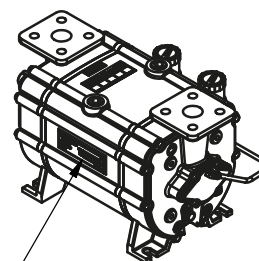

Location of ID plate

DOC107941A

7.2 How to order

Example:		OM	250	R	0	S	S	S	1	0	P	SD
Model:	250											
Rotation:												
Clockwise		R										
Counter clockwise		L										
Rotor type:												
Welded AISI 316			0									
Pump housing:												
Cast iron EN-GJL-250; EN1561				S								
Shell:												
Cast iron EN-GJL-250; EN1561					S							
Flow plates:												
Cast iron EN-GJL-250; EN1561						S						
Stainless steel AISI 316						E						
Generation of pump:												
1 or 2								1				
Gaskets:												
Oakenstrong										0		
Colour:												
Grey primer											P	
Ocean Master Blue											S	
On request											X	
Documentation:												
Samson standard												SD
ATEX Zone 1												X1
ATEX Zone 0												X5

7.3 Spare parts

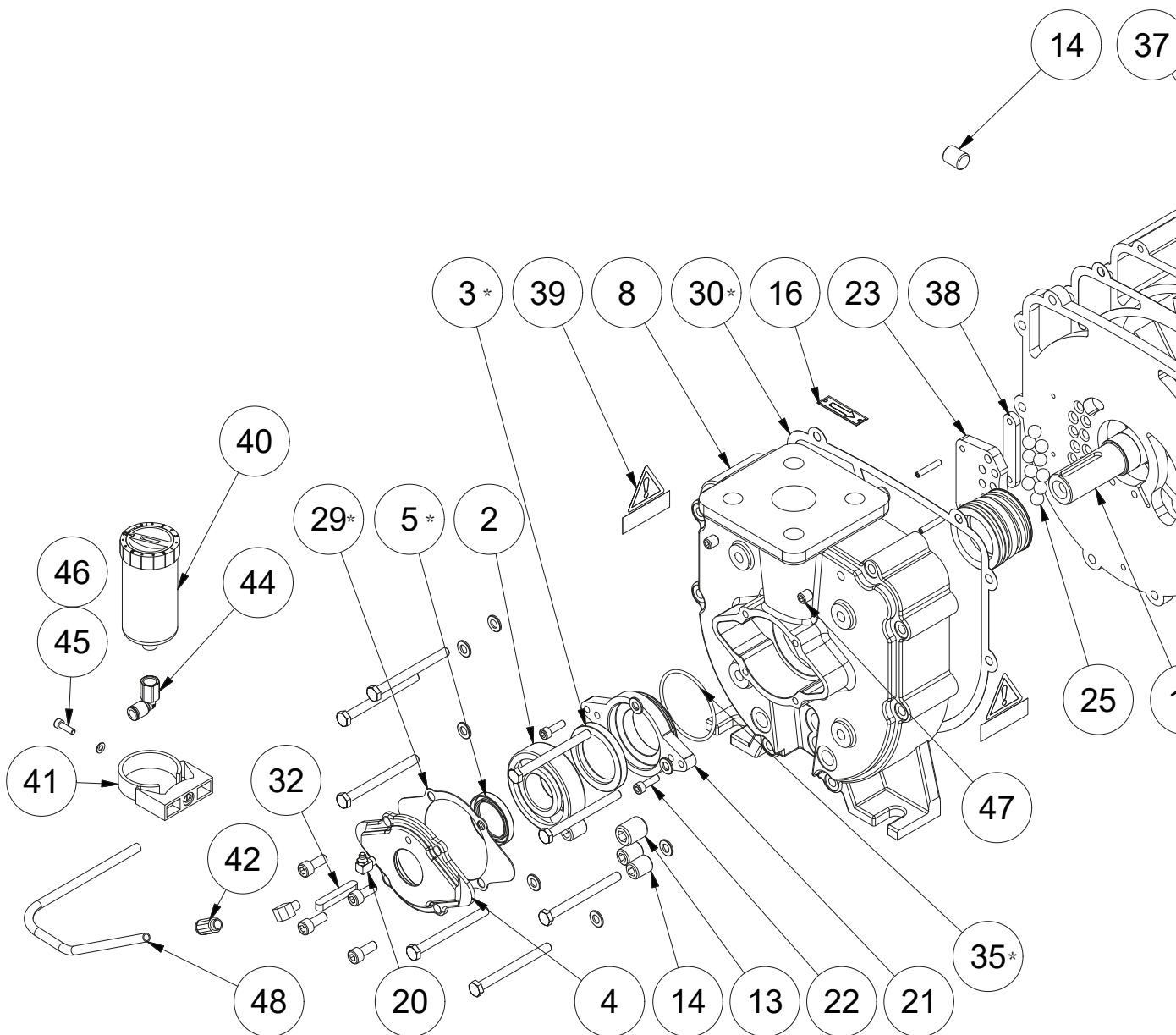

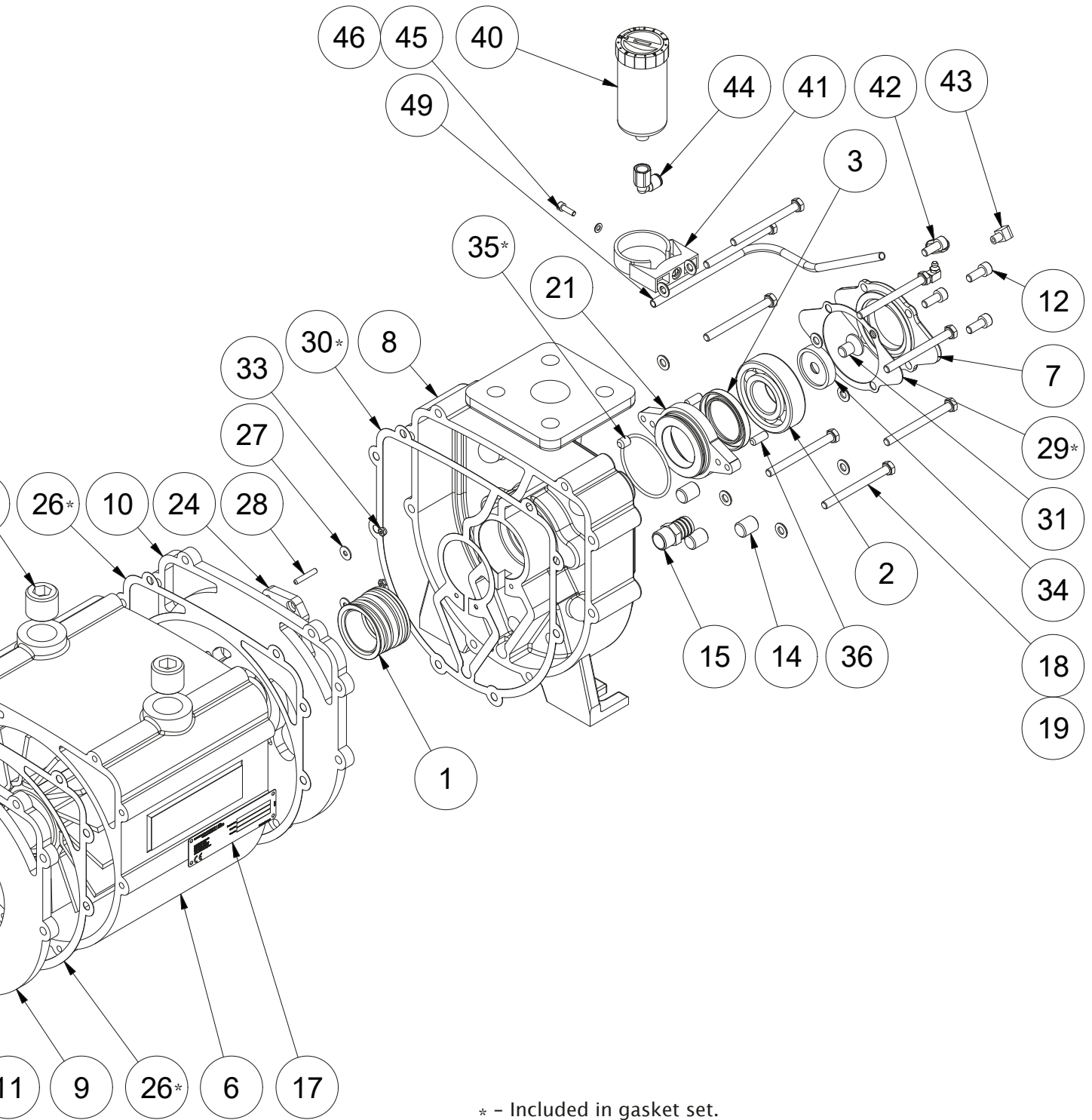

Pos.	Part number	Description	Qty.	Material
1	922000042	Mechanical shaft seal	2	Steel
2	930000078	Ball bearing	2	Steel
3	1600003	Gasket set Ocean Master 250	1	-
4	1622072	Bearing cover DE	1	Cast iron
5	1600003	Gasket set Ocean Master 250	1	-
6*	1622036	Shell	1	Cast iron
	1622067	Shell	1	Coated
7	1622071	Bearing cover NDE	1	Cast iron
8	1622069	Pump housing	2	Cast iron
9*	1622038	Flow plate	1	Cast iron
	1622019	Flow plate	1	Stainless steel
10*	1622040	Flow plate	1	Cast iron
	1622020	Flow plate	1	Stainless steel
11	1622043	Rotor R	1	Stainless steel
12	910300024	Allen screw	8	Steel
13	910300184	Plug	1	Brass
14	910300188	Plug	7	Brass
15	925000246	Hose nipple	1	Brass
16	-	Direction arrow	1	Aluminum
17	-	Identification plate	1	Stainless steel
18	910000020	Bolt	16	Steel
19	910100007	Washer	16	Steel
20*	915000197	Grease nipple	2	Steel
21	1622074	Adjustment plate	2	Cast iron
22	910300447	Allen screw	6	Stainless steel
23	1622024	Ball guide	1	Plastic
24	1622025	Ball guide	1	Plastic
25	962000047	Valve Ball	20	Plastic
26	1600003	Gasket set Ocean Master 250	1	-
27	910100149	Washer	4	Stainless steel
28	910300446	Socket set screw	4	Stainless steel
29	1600003	Gasket set Ocean Master 250	1	-
30	1600003	Gasket set Ocean Master 250	1	-
31	910300459	Allen screw	1	Steel
32	915000210	Parallel key	1	Steel
33	910200107	Lock nut	4	Stainless steel
34	1622075	Washer	1	Stainless steel

* -See section 7.1 for identification of pump.

**-Optional. Not equipped as standard.

Pos.	Part number	Description	Qty.	Material
35	1600003	Gasket set Ocean Master 250	1	-
36	910300125	Socket set screw	2	Steel
37	910300182	Plug	2	Stainless steel
38	1622026	Spacer for ball guide	2	Stainless steel
39	1624020	Sticker Warning!	2	Plastic foil
40**	915000225	Automatic lubricator LAGD 125/WA2	2	Plastic / grease
41**	915000232	Clamp for automatic lubricator	2	Plastic
42**	944600239	Push-in nipple	2	Brass
43**	944600173	Elbow	2	Brass
44**	944600240	Elbow	2	Brass
45**	910300221	Allen screw	2	Steel
46**	910100002	Washer	2	Steel
47	910300281	Plug	4	Steel
48**	915000217	Plastic pipe	0,3 m	Plastic
49**	915000217	Plastic pipe	0,3 m	Plastic

* -See section 7.1 for identification of pump.

**-Optional. Not equipped as standard.

7.4 Adaptor

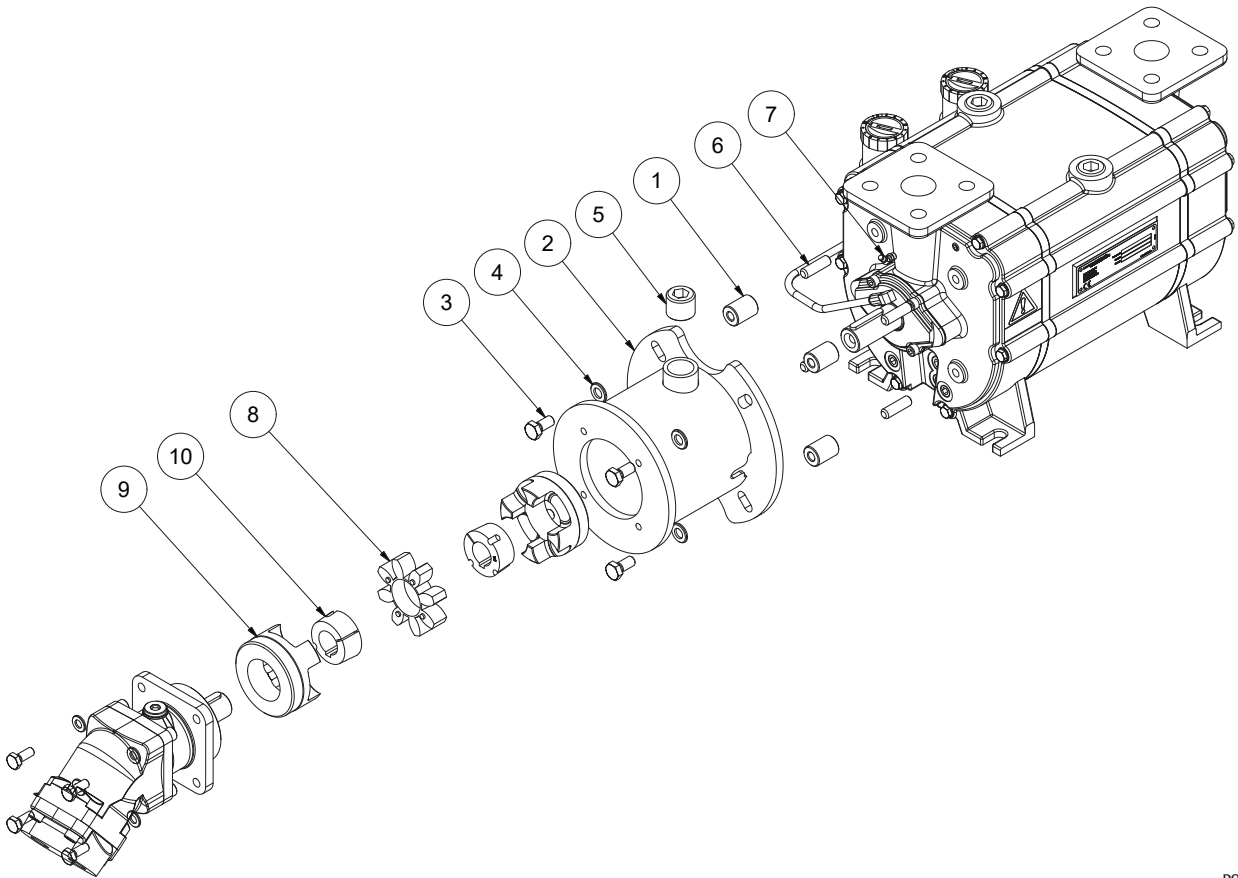

DOC1627386_1

Pos.	Part number	Description	Qty.	Material
1	1613110	Bush	4	Steel
2	1634738	Adaptor for hydraulic motor	1	Steel
3	910000160	M12x25 set screw	4	Steel
4	910100016	M12 washer	4	Steel
5	910300182	Plug 1"	1	Steel
6	910300445	M12x40 socket set screw	4	Steel
7	915000054	Grease nipple	1	Steel
8	932400120	Rubber element	1	Rubber
9	932400121	Half coupling	2	Cast iron
10	932300029	Taperlock bush	2	Cast iron

7.5 Gasket set

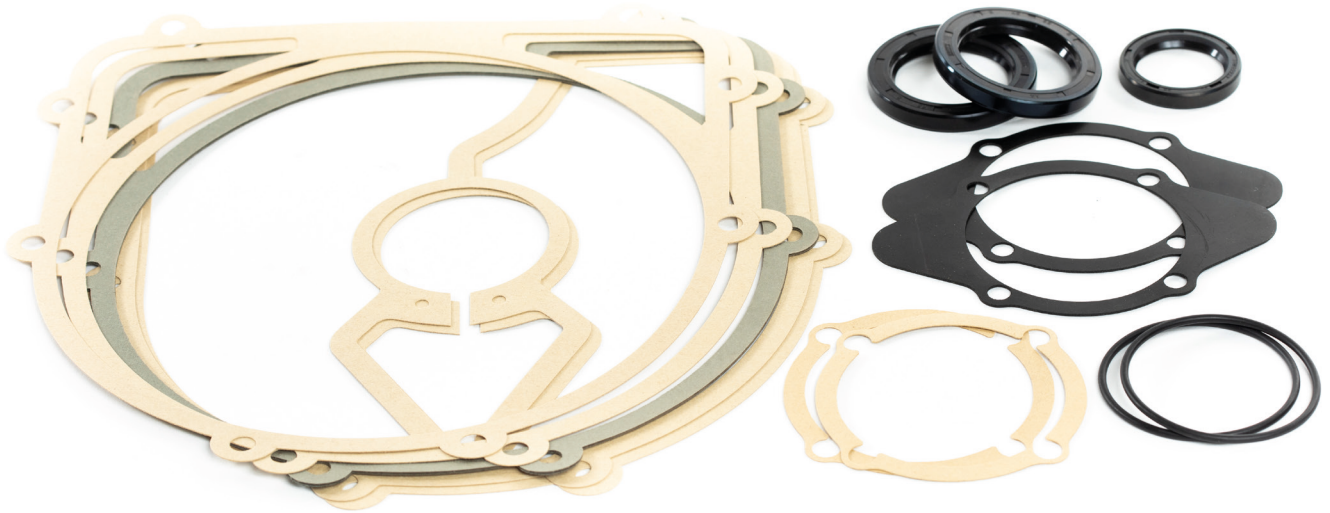

DOC11592

Pos.	Part number	Description	Qty.	Material
3	922200051	Radial shaft seal 45x65x8	2	Rubber / Steel
5	922200022	Radial shaft seal 35x50x7	1	Rubber / Steel
	922200020	Radial shaft seal 35x47x7 (<2012)	1	Rubber / Steel
26	1622027	Gasket for shell / flow plate 0,4 mm	2	Paper
	1622066	Gasket for shell / flow plate 0,8 mm	2	Paper
29	1622076	Gasket for bearing cover 1 mm	2	Rubber
	1622029	Gasket for bearing cover 0,4 mm (<2012)	2	Paper
30	1622028	Gasket for pump housing / flow plate 0,4 mm	2	Paper
35	922100361	O-ring Ø64,50x3,00	2	Rubber

See spare parts drawing (DOC1627387_2) for positions.

7.6 Special tool set

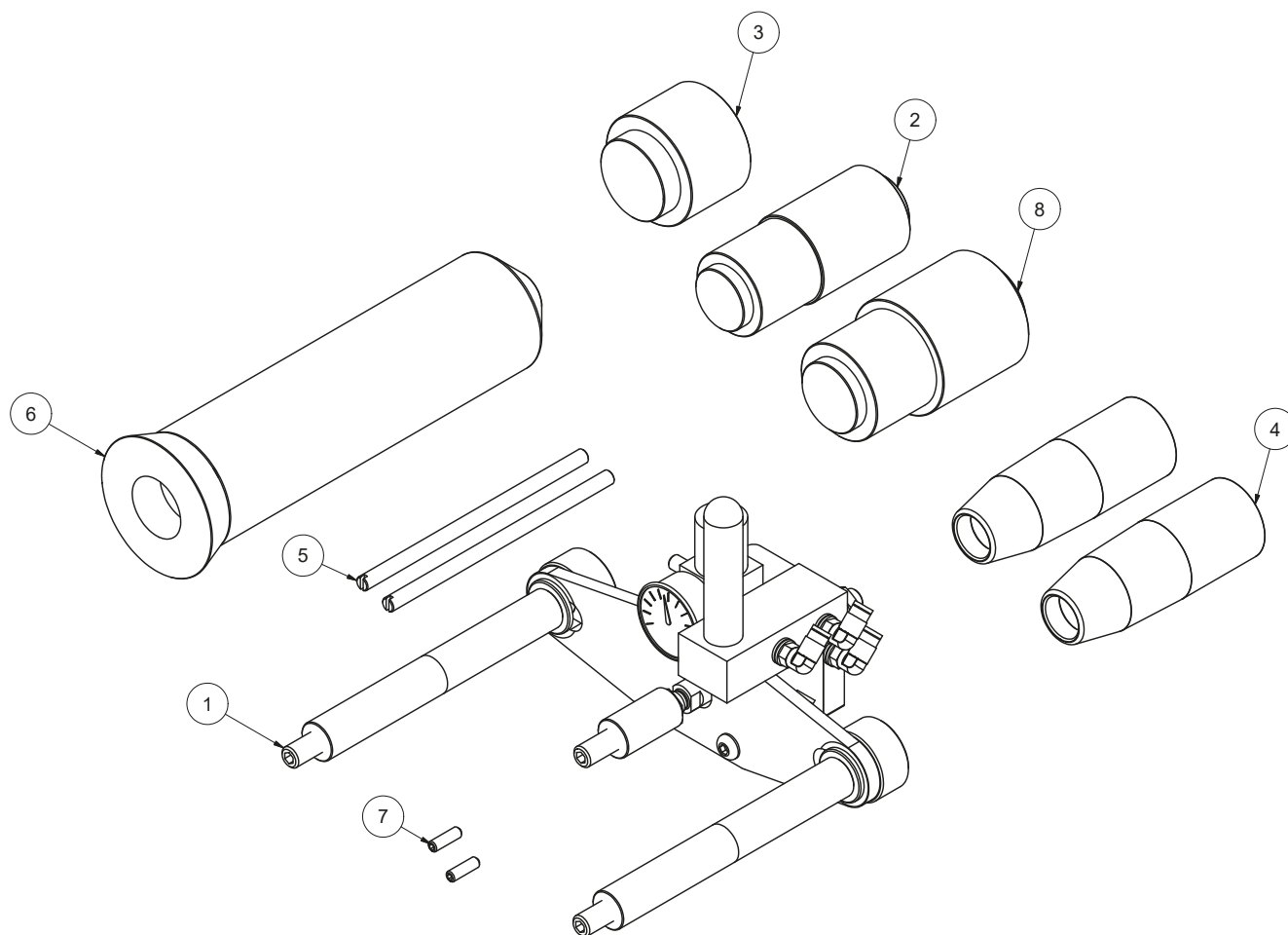

DOC1629198_1

Pos.	Part number	Description	Qty.	Material
1	1629136	Bearing tool	1	Steel
2	1629195	Mandrel radial shaft seal Ø35	1	Plastic
3	1629197	Mandrel mechanical shaft ring	1	Plastic
4	1629098	Assembly bush	2	Plastic
5	1629194	Guide pin M8	2	Steel
6	1629192	Bearing mounting tool	1	Plastic
7	910300428	Socket set screw	2	Steel
8	1629196	Mandrel radial shaft seal Ø40 + Ø45	1	Plastic

SAMSON PUMPS

Samson Pumps is the only company in the world to specialise exclusively in liquid ring vacuum pumps. Samson pumps are made in Denmark and used around the globe. We offer worldwide delivery, and we export to more than 80 countries around the world.

For over 40 years, our name has been synonymous with the strongest pumps for vacuum trucks and tankers. We constantly adapt our products to meet the changing needs of our customers. Today, it is not enough to simply produce a pump. Products must be refined so the customer can concentrate on what they do best. We therefore offer a wide range of standardised components that allow our customers to build vacuum systems without the need for specialist in-house expertise.

Strength and durability are our hallmarks! We have often heard from customers that our pumps are working in many years, and in most cases without the need for maintenance or repair. This emboldens us to say that we have the strongest program of pumps on the market.