

INSTRUCTION MANUAL

LIQUID RING PUMP



ATEX APPROVED



Zone 0 Internal / Zone 1 External

TRUCK MASTER[®] 3400

INSTRUCTION MANUAL FOR SAMSON LIQUID RING PUMP
TRUCK MASTER 3400

-
- Technical data
 - Design of a system
 - System layout
 - Installation and start-up
 - Service
 - Troubleshooting

The English version of the instruction manual is the legally binding version.

CONTENTS

1	Introduction	4
1.1	Declaration of conformity.....	4
1.2	Explanation of warning symbols.....	5
1.3	Disposal.....	5
1.4	ATEX Directive 2014/34/EU	6
1.5	Field of application.....	7
2	Technical data.....	8
2.1	Dimensions.....	8
2.2	Specifications.....	9
2.3	Power consumption and output.....	10
2.3.1	Vacuum	10
2.3.2	Pressure.....	10
2.3.3	Correction factor - Temperature	11
2.3.4	Correction factor - Wet and dry gas.....	11
2.4	Handling and transport	12
2.5	Pump storage and draining procedure.....	13
3	Design of a system	14
3.1	Function and design of a liquid separator.....	15
3.2	Air cooling with fan cooler	16
3.3	Fan cooler	17
3.4	Water consumption	18
3.5	Dome valve system	18
3.6	System layout (Zone 0/1)	19
3.6.1	Safety Integrity Level (SIL) according IEC 61508.....	21
3.6.2	Priming of the pump	21
3.6.3	Draining the pump.....	21
3.7	Liquid separator.....	22
3.8	Cavitation	23
3.9	Water requirement	23
3.10	Pipe system.....	24
3.11	Suction filter	24

- 4 Installation and start-up.....25**
 - 4.1 Securing the pump..... 25
 - 4.2 Connections to the pump..... 25
 - 4.3 Connecting the water 26
 - 4.4 Transmission 26
 - 4.5 Earth connection requirements..... 27
 - 4.6 Prior to start-up..... 28
 - 4.7 Direction of rotation 28

- 5 Service, operation, maintenance and inspection intervals..... 29**
 - 5.1 Inspection of bearings..... 29
 - 5.2 Inspecting for leakage..... 29
 - 5.3 Draining the liquid separator and the pump 29
 - 5.4 Check grease cartridges 30
 - 5.5 Inspection of ATEX safety device 30
 - 5.6 Inspection and cleaning of water supply pipe 30
 - 5.7 Calibration of ATEX safety device 30
 - 5.8 Overhaul of pump 30
 - 5.9 Winterization..... 30

- 6 Troubleshooting31**

- 7 Spare parts and tools.....32**
 - 7.1 Marking and identification..... 32
 - 7.2 How to order..... 33
 - 7.3 Spare parts – GENERATION 1 34
 - 7.4 Spare parts – GENERATION 2 38
 - 7.5 Gasket set..... 42
 - 7.6 Special tool set..... 43

1 INTRODUCTION

1.1 Declaration of conformity

SAMSON PUMPS

Declaration of Conformity

Annex IIA

Samson Pumps A/S
Petersmindevej 21
DK-8800 Viborg



Hereby declares that the following products:

Liquid ring pumps
TM3400, TM2500, TM1700, TM1600, TM600, TM350, SLP2100, SLP2700, SLP3100

Conforms to the following directives:

Machinery Directive 2006/42/EC
ATEX Directive 2014/34/EU

Explosion protection as follows on nameplate:

 II 1G Ex h IIC T4 Ga Internal
 II 2G Ex h IIC T4 Gb External

I hereby declare, that the machine are in conformity with the following harmonized standards:

DS/EN ISO 12100:2011	Safety of machinery - General principles for design - Risk assessment and risk reduction
DS/EN 1012-2 + A1:2009	Compressors and Pumps - Safety requirements - Part 2: Vacuum pumps
DS/EN 1127-1:2019	Explosive atmospheres - Explosion prevention and protection - part 1: Basic concepts and methodology
DS/EN ISO 80079-36:2016	Explosive atmospheres - Part 36: Non-electrical equipment for explosive atmospheres - Basic method and requirements
DS/EN ISO 80079-37:2016	Explosive atmospheres - Part 37: Non-electrical equipment for explosive atmospheres - Non-electrical type of protection constructional safety "c", control of ignition sources "b", liquid immersion "k"

The standard above only applies to the extent that it is relevant for the purpose of the pump.
The product must not be used before the complete system, which it must be incorporated in, has been conformity assessed and found to comply with all relevant health and safety requirements of 2006/42/EC and other relevant directives. The product must be included in the overall risk assessment.

EU TYPE-Examination Certificate Number **ExVeritas 19 ATEX 0452X**
Certification body Identification Number **2804**

Viborg, 07.12.2020

Jan S. Christiansen – Manager, Technical dept.

DOC4046D

E-Mail info@samson-pumps.com	Samson Pumps A/S	Petersmindevej 21
Web www.samson-pumps.com	Phone +45 87 50 95 70	DK-8800 Viborg

1.2 Explanation of warning symbols

Important technical and safety instructions are shown by symbols. If the instructions are not performed correctly, it can lead to personnel injuries or incorrect function of the pump.



To be used with all safety instructions that must be followed. A failure to follow the instructions may result in injuries and/or incorrect machine operation



This symbol stands for safety instructions which – if they are not observed – may lead to a risk of explosion. You must therefore always follow these instructions.

1.3 Disposal

Samson's liquid ring pump is manufactured so that most of the device can be reused/recycled.

Samson Pumps offer users of the company's pumps the option of returning used pumps to be restored or scrapped.

Alternatively, the pump must be taken apart and sorted into its separate components, by the customer (see section 7 for the pump's material).

These components must be disposed of in accordance with national regulations.

1.4 ATEX Directive 2014/34/EU

The pump may be incorporated into a larger system, if the internal atmosphere has an area classification of: Zone 0 (for ATEX category 1 pumps)

These systems will be certified in accordance with the ATEX Directive 2014/34/EU

For the certification to be valid, the pump must be installed as described in this manual.



II 1G Ex h IIC T4 Ga Internal

II 2G Ex h IIC T4 Gb External

ExVeritas 19 ATEX 0452X

Explanation of symbols and characters used in ATEX marking:



The European Commission's mark for Ex products

- II Equipment group II (non-mining)
- 1 Equipment category
- G Type of explosive atmosphere (G = Gas)
- Ex Indication of equipment for use in potentially explosive atmospheres
- h Explosion protection
- IIC Gas group (explosion group)
- T4 Temperature class (T4 = 135°C)
- Ga Equipment protection level

ExVeritas 19 ATEX 0452X is the certificate number.

Special Conditions for Safe Use:

For pumps classified Ga (Zone 0), temperature monitoring is required on the bearings to initiate a shutdown of the equipment in case bearings exceed the temperature, listed under Section "System layout (Zone 0/1) in the Instruction Manual. The temperature sensors must be connected to a monitoring and shutdown system which is sufficiently reliable and compliant with the requirements for ATEX safety related devices and systems as defined in Annex II, clause 1.5.1 of Directive 2014/34/EU (i.e. b1 (SIL1) as defined by EN ISO 80079-37 cl. 6.5).

Refer to manufacturer's Instruction Manual for correct installation and maintenance.

1.5 Field of application



Inlet of foreign objects, including condensing gases can damage the pump



The pump is designed exclusively to pump gases, including atmospheric air



WARNING!
Do not operate the pump so that cavitation can occur! For further information see instruction manual for the Samson Pumps vacuum control valve

It must be ensured that the inlet gas cannot react with the water and create aggressive bonds that break down the pump's components.

For other operating data, see specifications.

- The pump may only be used with media that are not aggressive to the pump's materials. See section 7.3 for components and appertaining materials.
- When using ATEX-approved pumps, refer to the marking on the pump and the areas of application specified in the ATEX Directive.

2 TECHNICAL DATA

2.1 Dimensions

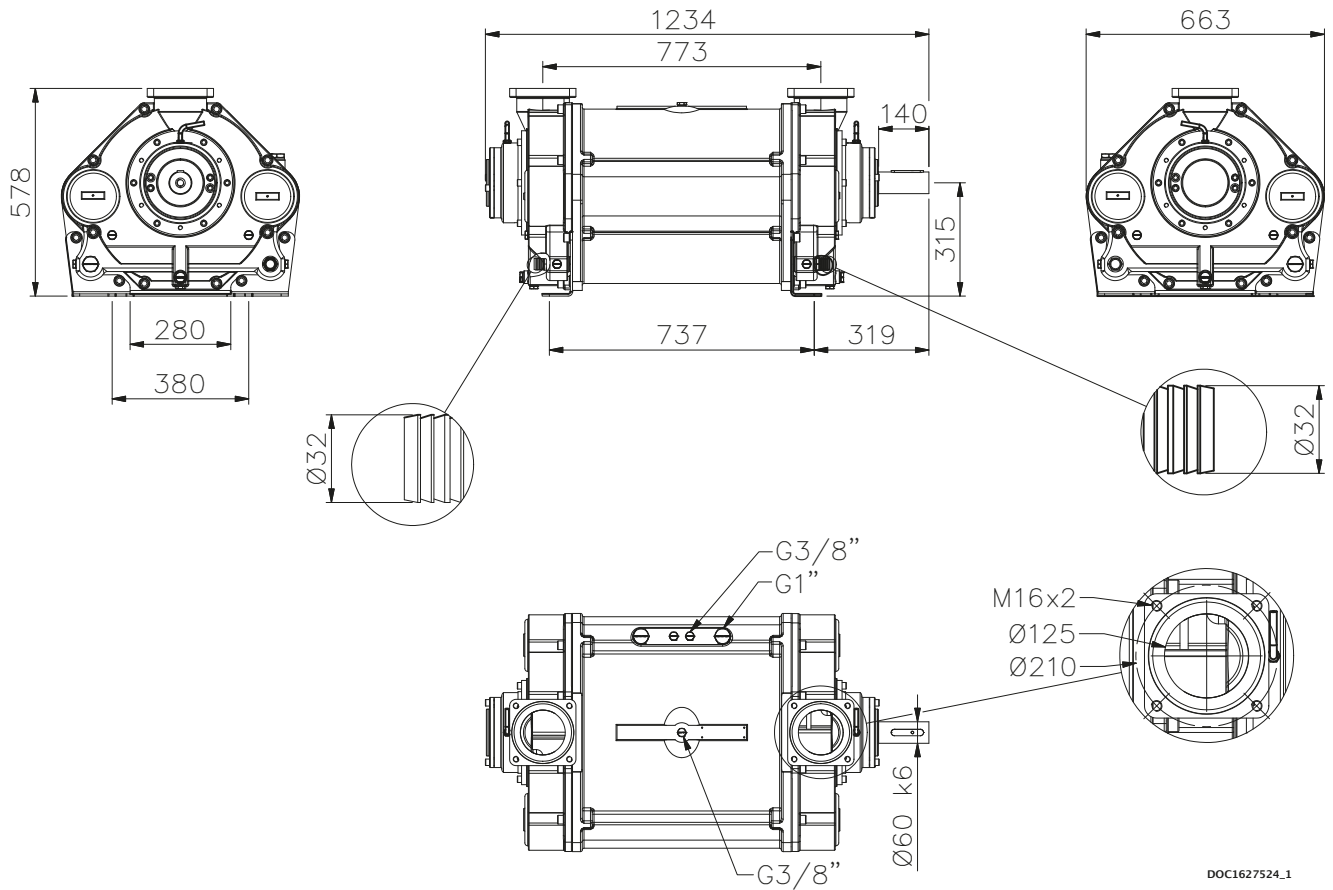

DOC1627524_1

2.2 Specifications



A failure to meet these specifications may result in damage to the pump and a potential risk of explosion

Description		Minimum	Maximum
Ambient temperature, operation	Below 0°C – see chapter 5.9	-20°C	55°C
Ambient temperature, storage		-20°C	55°C
Humidity		-	100%
Intake temperature, suction side		-	80°C
Intake temperature, water		-	60°C
Water pipe connection, dimension		1¼"	-
Water pipe connection, length		-	6 m
For all connections, it is recommended to use the pump's existing connection size as minimum size.			
Noise level		-	80 dB(A)
Water volume		-	52 L
Maximum radial load on drive shaft		-	14000 N
Heat input for cooler calculation	1100 rpm	48 kW	-
	1200 rpm	57 kW	-
	1300 rpm	68 kW	-
	1400 rpm	80 kW	-
Revolutions		800 rpm	1400 rpm
Pressure		150 mbar abs.	0,75 bar(g)
Lubricating grease	Type of grease	SKF LGWA2	
	Automatic lubrication*	SKF LAGD 125/WA2	
Weight		531 kg	

It is required to install liquid separator to ensure the pump is supplied as much water as needed. See System layout Zone 0/1.

* -Automatic lubrication: Zone 0/1 – Requirement.

2.3 Power consumption and output

2.3.1 Vacuum

	Vacuum	[%]	80	70	60	50	40	30	20
1100 [rpm]	Flow _{Wet}	[m ³ /h]	2292	2706	2740	2839	2736	2572	2514
	Flow _{Dry}	[m ³ /h]	1711	2114	2383	2512	2510	2382	2350
	Consumption	[kW]	64						
	Torque	[Nm]	556						
1200 [rpm]	Flow _{Wet}	[m ³ /h]	2434	2964	2993	3078	2888	2837	2840
	Flow _{Dry}	[m ³ /h]	1816	2316	2603	2725	2650	2627	2654
	Consumption	[kW]	77						
	Torque	[Nm]	613						
1300 [rpm]	Flow _{Wet}	[m ³ /h]	2482	3196	3230	3347	3111	3069	3019
	Flow _{Dry}	[m ³ /h]	1852	2497	2808	2962	2855	2841	2822
	Consumption	[kW]	92						
	Torque	[Nm]	676						
1400 [rpm]	Flow _{Wet}	[m ³ /h]	2476	3415	3357	3323	3286	3304	3243
	Flow _{Dry}	[m ³ /h]	1848	2669	2919	2940	3015	3059	3031
	Consumption	[kW]	108						
	Torque	[Nm]	737						

2.3.2 Pressure

	Pressure	[bar(g)]	0	0.25	0.5	0.75
1100 [rpm]	Flow	[m ³ /h]	2102	1974	1871	1787
	Consumption	[kW]	56	65	72	82
	Torque	[Nm]	486	564	625	712
1200 [rpm]	Flow	[m ³ /h]	2387	2197	2133	2068
	Consumption	[kW]	74	80	89	98
	Torque	[Nm]	589	637	708	780
1300 [rpm]	Flow	[m ³ /h]	2560	2441	2351	2281
	Consumption	[kW]	90	96	105	117
	Torque	[Nm]	661	705	771	860
1400 [rpm]	Flow	[m ³ /h]	2766	2623	2570	2502
	Consumption	[kW]	104	110	123	133
	Torque	[Nm]	709	750	839	907

The data Flow_{Dry} is based on the following parameters:

- Air temperature 20°C
- Water temperature 15°C
- Test performed with dry air and 1,013 mbar absolute pressure
- Tolerance ±10%

2.3.3 Correction factor – Temperature



Suction pressure and water temperature to be adjusted in such way that cavitation cannot occur

When the temperature of the water exceeds 15°C, the pump’s capacity will be affected with respect to the specified values.

To determine the output at a higher temperature, the correction factor can be used.

Capacity at water temperature higher than 15°C :

$$Q_{t>15} = Q_{15} \times K_1$$

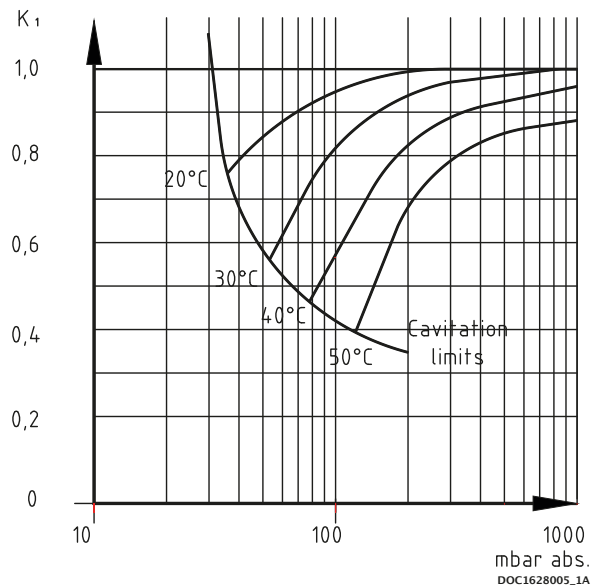

2.3.4 Correction factor – Wet and dry gas

Normal atmospheric air contains water vapor. In this case water will condense inside the pump and will create a higher flow.

Below you can find a correction factor table for the performance based on condensing gas with an inlet temperature of 50°C 100% saturated and service liquid temperature of 15°C.

Suction pressure % Vacuum	80	70	60	50	40	30	20
Correction factor wet gas K_{Wet}	1,34	1,28	1,15	1,13	1,09	1,08	1,07

The performance of the pump can thereby be calculated as:

$$V_{Wet} = V_{Dry} \times K_{Wet}$$

2.4 Handling and transport



The pump must not be used if it is damaged or the identification plate is missing
ATEX marking must correspond to the area the pump is operating in

The pump must be transported in such way that it is not exposed to vibrations and impacts that can overload the bearings.

The pump must be inspected for damages upon delivery. If the pump is damaged, it must not be used and the damage must be reported to the manufacturer.

Ensure that the pump's identification plate is intact and that the marking of the pump corresponds to its use.

The pump must only be handled using approved lifting eyes, in accordance with nationally applicable regulations and only in a vertical motion.

The pump can be transported in the following ways:

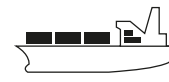
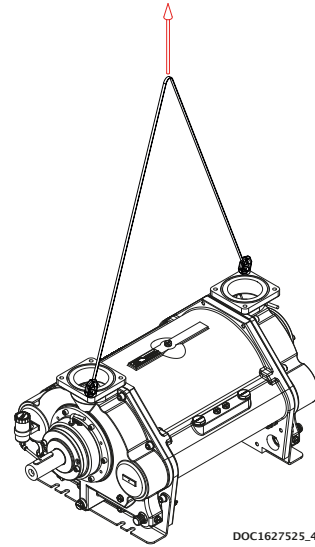

2.5 Pump storage and draining procedure



A failure to comply with the requirements for storing the pump may result in internal damage to the device



If the temperature is below freezing point of the service liquid, it could damage the pump. Under these conditions, the pump must be drained completely.



All plugs and protective covers must be fitted during storage.

The pump's water is drained on delivery, and the pump can be immediately stored in accordance with the technical specifications.

After operation, the pump can be stored for 30 days without further action.

If the pump remains out of operation for a longer period of time after use, its water must be drained, and the water supply to the pump must be shut off.

When emptying the pump, it is important that all chambers inside the pump are emptied.

To empty the correct chambers (X) depends on the rotation of the pump (CW or CCW). See table below.

The pump can be fitted with valves in the draining connections. See below.

Chamber \ Rotation	A	B	C ₁ or C ₂	D ₁ or D ₂ or D ₃ or D ₄
CW	X		X	X
CCW		X	X	X

Draining during normal operation, see chapter 5.

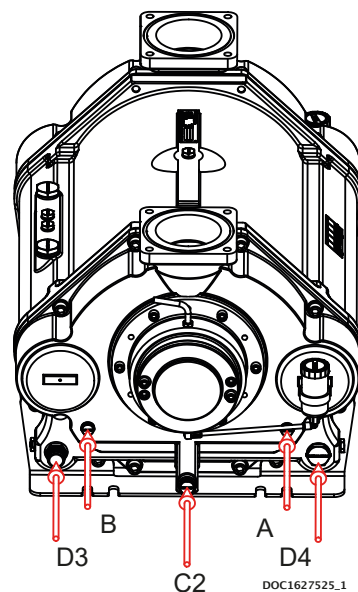
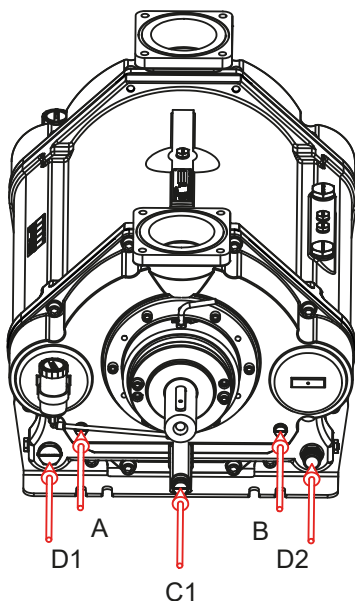

DOC1627525_1

3 DESIGN OF A SYSTEM

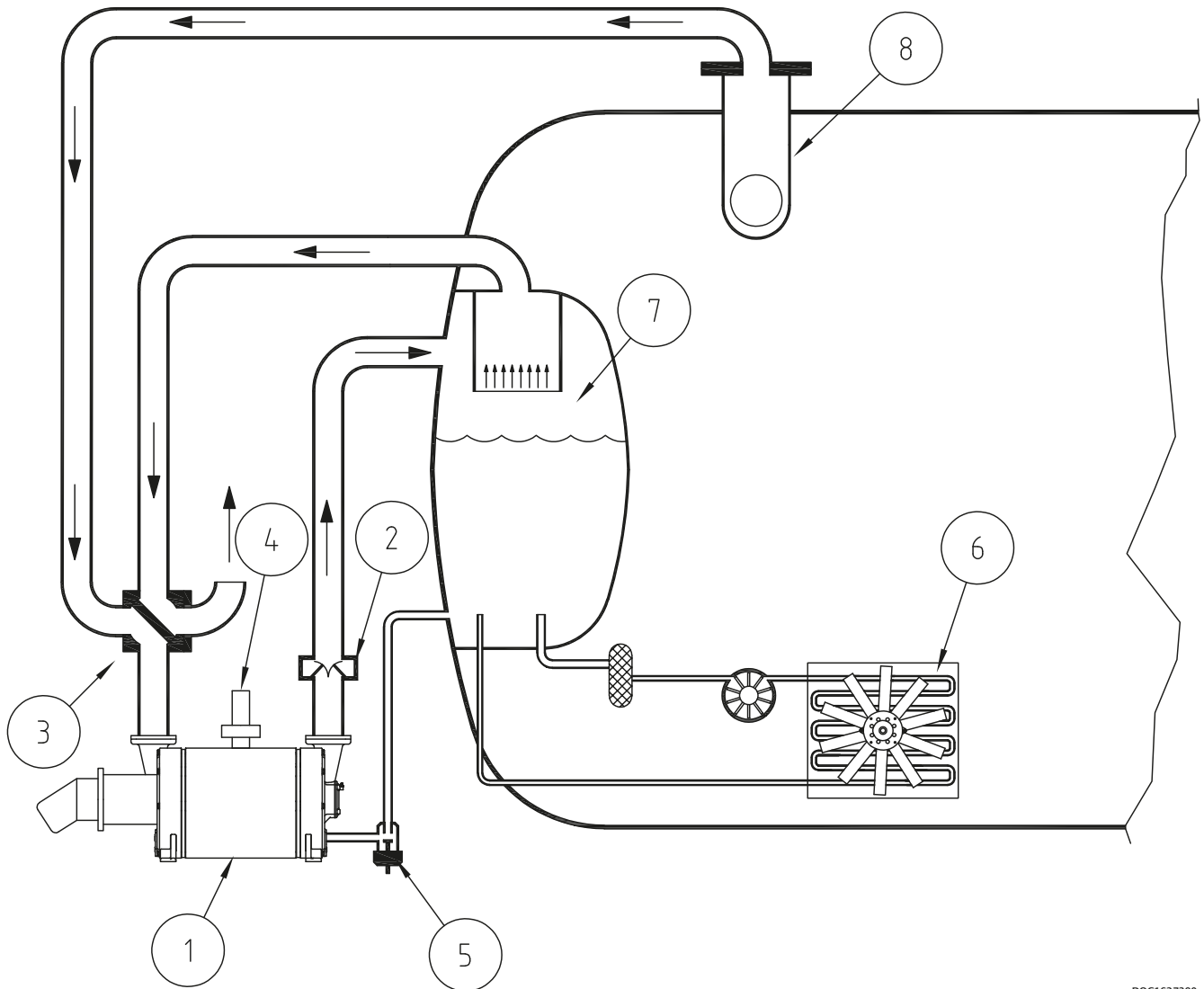

DOC1627390

Pos.	Description
1	Liquid ring pump
2	Non return valve
3	4-way valve
4	Vacuum control valve
5	Water control valve
6	Fan cooler
7	Liquid separator
8	Dome valve

3.1 Function and design of a liquid separator

Together with the air there will be a water flow out of the pump up to 6 m³/h.

The water will be separated from the air in the liquid separator.

Depending of the size of particles, water will be carried with the water when the air velocity is more than 3-4 m/s.

The inlet speed to the separator can be more than 50 m/s and this must be reduced to 3 m/s.

Below you find an illustration showing how to reduce the speed and control that no water will be in contact with the high velocity air stream. The round velocity reducer can be placed inside any tank geometry.

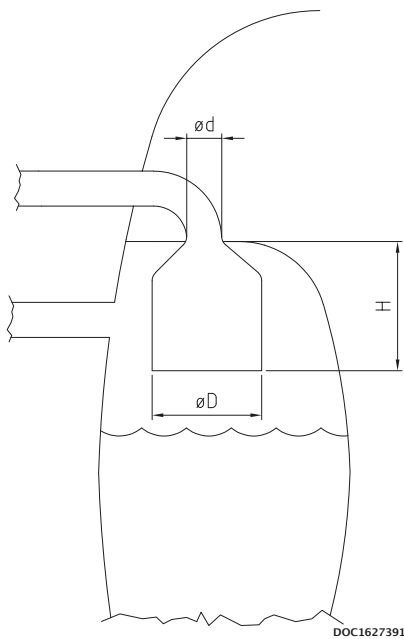

Air flow [m ³ /h]	øD minimum [mm]
3400	600
3300	590
3200	580
3100	570
3000	560
2900	550

øD so the velocity is below 3 m/s

H=4 to 6*ød depending on the geometry. A smooth diameter conversion will give a low factor.

3.2 Air cooling with fan cooler

Compression of air inside the liquid ring pump will create heat that is transferred to the water.

Therefore, it can be necessary to install a fan cooler depending on the expected use, the climate etc. The time it takes to heat up the water also depends on for example ambient temperature, suction pressure, amount of water and the cooling effect in the truck itself.

The operation temperature will go up until there is a balance between the heat input and the heat output. So basically, there are only two things that can lower the operation temperature. Reduce the heat input or increase the heat output.

The amount of water has no or only a little influence on the final operating temperature. The truck itself will work as a big radiator and if there is a huge amount of water in the liquid separator and thereby good contact area between the water and the steel tank, it will give a higher cooling effect. This in combination with low ambient temperature and short time of operation, could mean that the truck can operate without any additional cooling.

In general, the time it takes to heat up the water can be calculated from the formula below.

$$t_{\text{sec}} = \frac{C_p \times m \times \Delta t}{Q}$$

t_{sec} = Time in seconds

C_p = Heat capacity of the media. Water= 4,2

Δt = Temperature difference

m = Mass of the media heating up [Kg]

Q = Heat input in [kW] See specifications, chapter 2.2

Example:

We have a tank with 300 litres of water corresponding to 300 kg. The heat input is 30 kW. How long will it take to heat it up from 20°C to 40°C ?

$$t_{\text{sec}} = \frac{4,2 \times 300 \times 20}{30} = 840 \text{ s} = \underline{14 \text{ min}}$$

The temperature will continue to go up until the steel construction can absorb the heat and transfer it to the surroundings.

With a temperature difference on 20°C it is typical to have a radiator affect in a truck on somewhere between 5 to 20 kW depending on the construction.

The table below shows truck radiator effect at a temperature difference of 20°C.

5 kW	10 kW	20 kW
Small liquid separator mounted external from the truck tank Water content below 100 L	Small liquid separator inside slurry tank. Located with only minor contact to the product Water content 300 L	Normal liquid separator inside slurry tank with good contact to the product Water content 400 L

3.3 Fan cooler

The fan cooler will increase the heat output from the construction and thereby stabilize the temperature at a lower level. However, this cooler will use the air to cool down the water and therefore we will always see that the temperature will be stabilized above the ambient temperature. It's very simple to find the right cooler based on the curves from the cooler manufacturer. Typically you will find the cooler capacity as kW/Δt meaning for example 1.5 kW cooler capacity each °C in temperature difference between the water and the air. Note that the water flow through the cooler will also affect the cooling capacity.

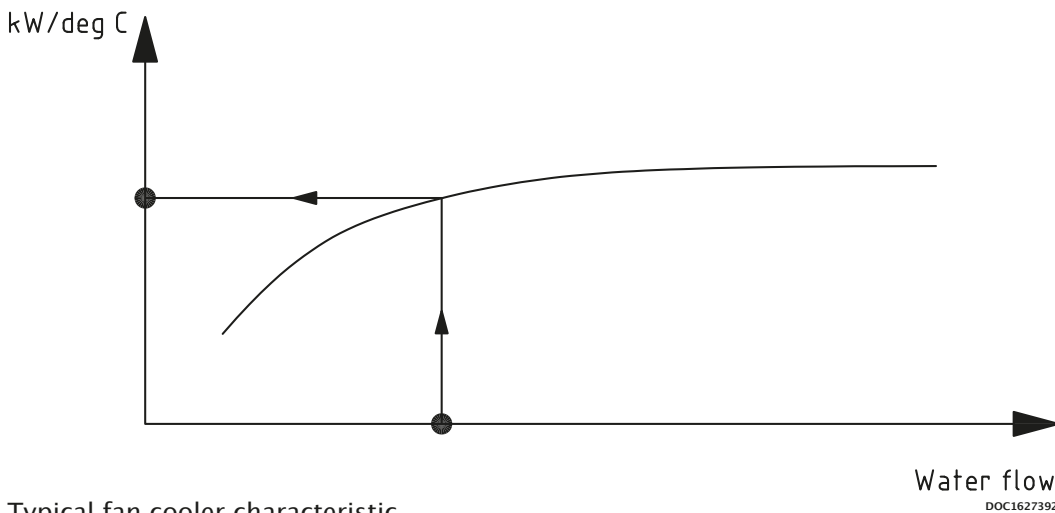

Typical fan cooler characteristic.

Practical calculation example:

The truck is used mostly to work with an operation pressure around 70% vacuum. From the technical data sheet, we find the heat input from the pump to be 68 kW.

The liquid separator is built inside the slurry tank with a good contact to the product and a radiator effect estimated to 20 kW with a temperature difference of 20°C.

The truck will work with ambient temperature up to 28°C during the summer and we will accept a maximum temperature on 40°C.

First, we have to reduce the radiator effect based on a temperature difference of 12°C.

$$Q_{\text{out Truck}} = 20 \times \frac{12}{20} = 12 \text{ kW}$$

The total cooling effect required is thereby:

$$Q_{\text{out Pump}} - Q_{\text{out Truck}} = 68 - 12 = \underline{56 \text{ kW}}$$

Summary

Pump model	Description	Truck Master 3400
Heat input from technical specifications	$Q_{in Pump}$	68 kW
Ambient temperature	t_{amb}	28°C
Maximum Working Temperature of the water. This is determined by you. The temperature has influence on the pump performance	t_{op}	40°C
Temperature difference	Δ_t	$t_{Op} - t_{amb} = 12^\circ C$
Truck radiator effect based on 20 °C in temperature difference	$Q_{out Truck 20}$	20 kW
Truck radiator effect based on 12 °C in temperature difference	$Q_{out Truck 12}$	$12/20*20 = 12 \text{ kW}$
Total cooling requirement from fan cooler	$Q_{fan cooler}$	$Q_{in Pump} - Q_{out Truck 12} = 68 - 12 = 56 \text{ kW}$

We need to find a fan cooler that can transfer 23 kW with a temperature difference on 12°C. That is 1,92 kW/°C.

If we for example accept a higher temperature, for instance 48°C, we will have full cooling effect from the truck on 20 kW and a cooling requirement on 15 kW. The fan cooler we need to find is thereby on $15/20 = 0,75 \text{ kW/}^\circ C$ and a big difference to the bigger model calculated above.

3.4 Water consumption

It is possible to design the liquid separator so that almost 100% of the water is separated from the air. However, the air will be heated up and thereby it can content more water. Also, the relative humidity will go up and end near 100%.

So, the air will flow into the pump with maybe 50% relative humidity at a low temperature and be discharged at a higher temperature and humidity. Therefore, there will be an evaporation from the system.

Choose your water temperature

Temp. \ Vacuum	20°C	30°C	40°C	50°C	55°C
50%	32	50	86	140	220
70%	17	22	43	75	124
80%	12	20	34	56	88

Water consumption Liters per hour

3.5 Dome valve system

The liquid ring pump can handle liquid and particles in the inlet but it is of course recommendable to avoid this.

A dome valve or floating valve will ensure that the suction will be closed when the liquid level reaches the top of the tank.

In many situations there will be foam on the liquid surface inside the tank. It can be difficult to avoid that this will be transported into the suction line before the dome valve will close.

Therefore, it will be recommended to make a combination of a filter and dome valve as illustrated below.

The filter will prevent particles lifted by the foam to enter the pump.

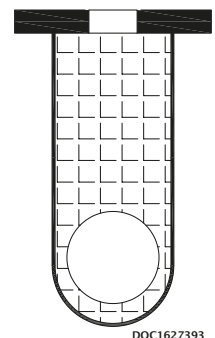

DOC1627393

3.6 System layout (Zone 0/1)



To safeguard the pump so that it can operate in potentially explosive areas, the components used in the safety device must stop the pump in the event of abnormal operation



The maximum working pressure must not exceed specifications, by installing a safety valve

The pump must be fitted with the safety device components specified in drawing below.

The water connection that feeds water to the pump must be fitted with flow meters in positions 8 and 9, on both valve inlets.

To prevent the loss of water, stop valves should be installed between the liquid separator and the pump. See Pos. 10 and 11. These valves must be closed when the pump is not in operation. The opening of the valves must be performed automatically when the pump starts.

Max. 1 m after the pump, a temperature sensor must be installed in position 7, which also serves as a safety device and which must stop the pump if the output temperature exceeds the limit.

The water level in the liquid separator must be monitored by a level sensor at position 6, which also stops the pump in the event of an insufficient level of water.

The 2 temperature sensors are placed in existing M10x1 threaded holes in the bearing housings. This is done by unscrewing existing plugs and mounting sensors instead. See illustration below.

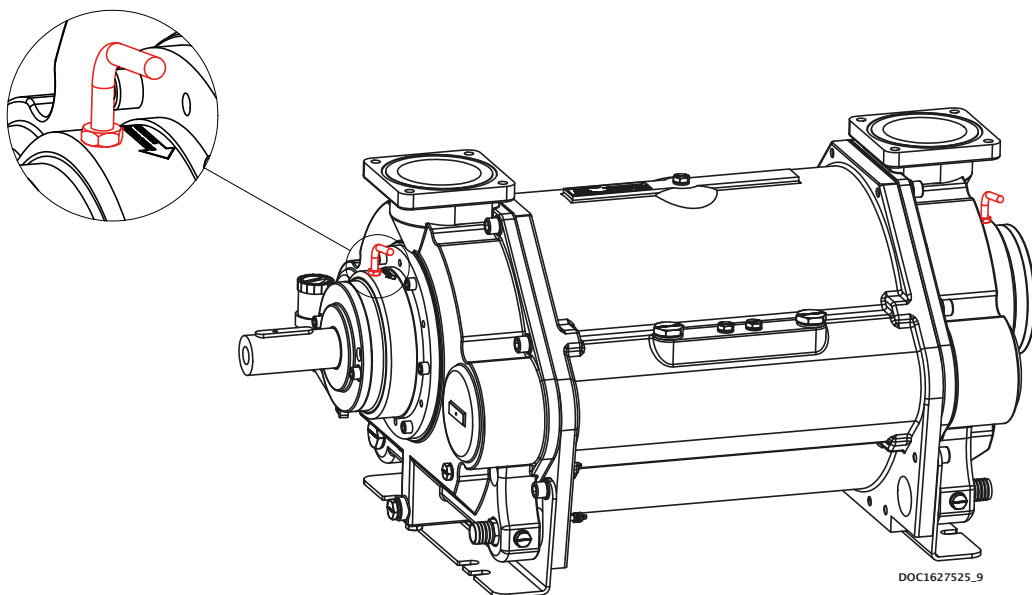

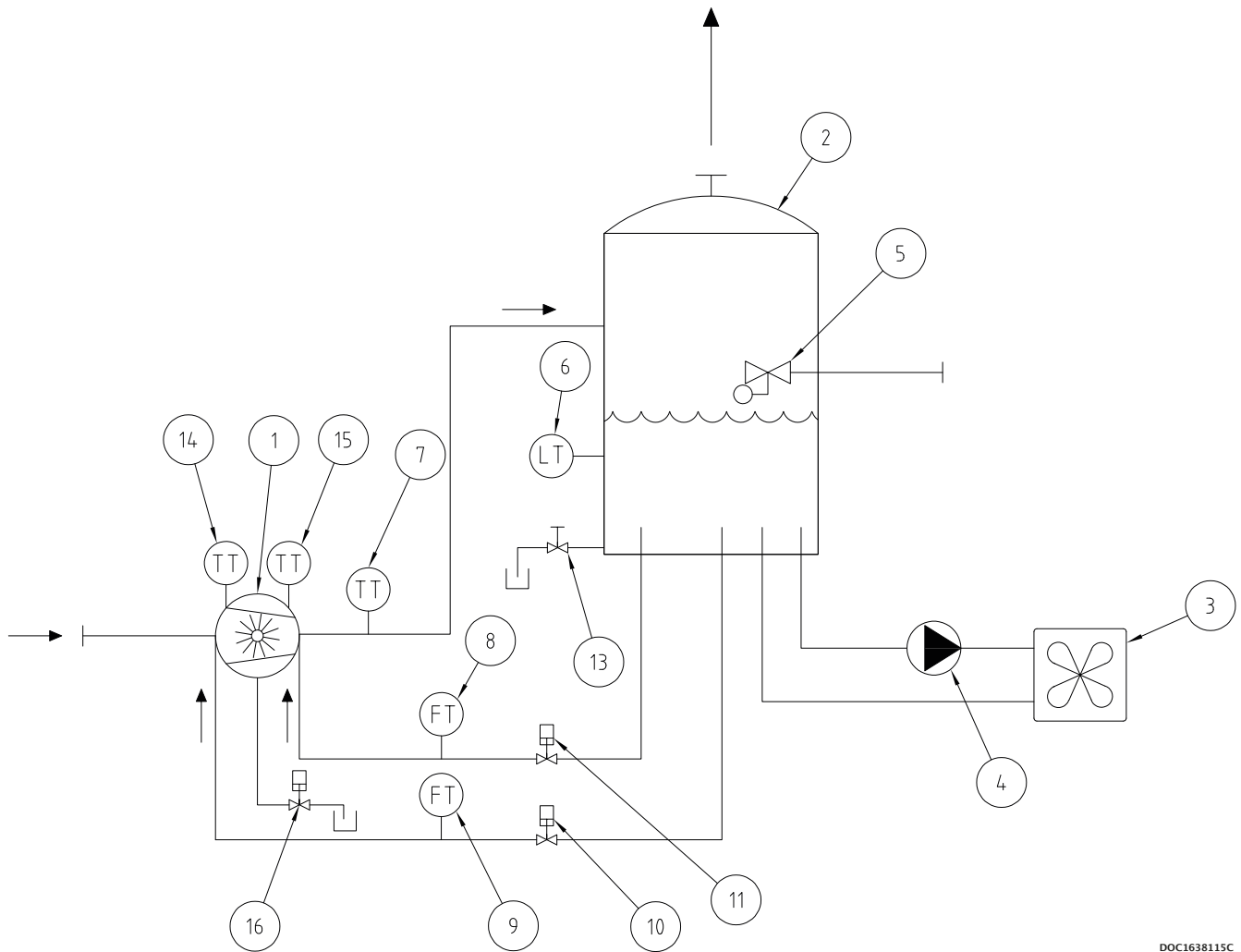

DOC1638115C

Pos.	Description		Set
1	Vacuum pump		-
2	Liquid separator		-
3	Cooler or heat exchanger		-
4	Circulation pump		-
5	Float valve		-
6	Level switch	safety device	Min. 50 L
7	Temperature transmitter	safety device	Max. 80°C
8	Flow meter	safety device	Min. 2 L/min. max. delay 10 sec.
9	Flow meter	safety device	Min. 2 L/min. max. delay 10 sec.
10	Stop valve		-
11	Stop valve		-
13	Drain valve		-
14	Temperature transmitter DE	safety device	Max. 105°C
15	Temperature transmitter NDE	safety device	Max. 95°C
16	Drain valve		-

* - Maximum pipe length from liquid ring pump 2 m.

See specifications from chapter 2.2 - Water pipe connection, dimension and length.

3.6.1 Safety Integrity Level (SIL) according IEC 61508

Description of Hazard	Position (Sensor)	Safety action required	SIL requirement to safety function
Increased temperature due to absence of water for mechanical shaft seal, NDE	Pos 6 (Level) & pos 8 (Flow)	Stop of pump	SIL2
Increased temperature due to absence of water for mechanical shaft seal, DE	Pos 6 (Level) & pos 9 (Flow)	Stop of pump	SIL2
Unacceptably elevated temperature in pump due to increased temperature of media	Pos 7 (Temperature in media)	Stop of pump	SIL2
Unacceptably elevated temperature of bearing, DE	Pos 14 (Temperature in bearing)	Stop of pump	SIL2
Unacceptably elevated temperature of bearing, NDE	Pos 15 (Temperature in bearing)	Stop of pump	SIL2

See page 21 for diagram.

3.6.2 Priming of the pump

If the pump is stopped due to missing flow signal from flow sensors pos 8 or pos 9 the control system must be designed to prime the pump before any restart is possible.

The priming procedure shall open stop valve pos 10 and pos 11 and stay open until the flow sensors pos 8 and pos 9 has positive flow for a continuously period of 10 seconds.

Only after this period the system can be started.

3.6.3 Draining the pump



When operating the drain valves, the outlet may contain explosive gases, corresponding to the classification of the pump's suction side

The pump can be equipped with a drain valve pos 16 according to system layout page 21.

The valve must be activated from the control panel with the following control philosophy.

- The drain valve must be installed in connection C₁ or C₂
- Activation of the valve must only be possible when the pump is stopped.
- When the draining procedure is activated the drain valve will be open for 60 seconds. After this interval the drain valve will close.
- Any start of the pump after draining must activate a priming sequence according to 3.6.2

3.7 Liquid separator



Liquid separator must be mounted in such way that the minimum level of water is minimum 0,5 m above the pump's shaft



When operating the drain valves, the outlet may contain explosive gases, corresponding to the classification of the pump's suction side

The liquid separator must be located in immediate proximity to the pump, so that the length of the outlet pipe from the pump is minimised. Due to potential pressure loss, the length may not exceed 2 metres. The level of water in the liquid separator is recommended to be kept at 1–1.5 metres above the pump's shaft. This ensures the correct influx pressure and the correct flow of water.

The water supply between the liquid separator and pump must be implemented with a permanent pipe connection with a dimension and length specified in specifications.

It may be advantageous to fit the liquid separator with a float valve which automatically supplies water and maintains a constant level.

The liquid separator can be fitted with a drain valve at the lowest place in the tank. The valve can be operated when the separator needs to be drained to remove contaminants.

3.8 Cavitation

When the temperature reaches the boiling point of the water, steam bobbles will be created in the liquid ring.

These bobbles cannot exist when they enter the discharge side of the pump and therefore they will collapse. The impact force on the surface of the rotor and flow plate will damage the pump and can lead to a total breakdown. It is a very harmful situation that must be avoided.

It is the combination of the pressure and the temperature that will lead to the cavitation. Therefore, it is recommended to install 2 vacuum control valves, see illustration below that shows a clockwise rotating pump. If counter-clockwise rotating pump, mount in opposite manifold.

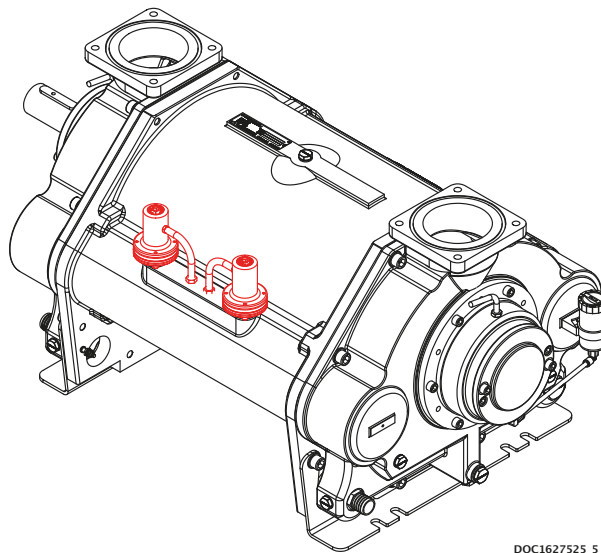

DOC1627525_5

Below you find the boiling point of water as a function of the pressure.

Vacuum	50%	75%	80%	90%
Temperature °C	80	64	59	44
Maximum discharge temperature	70	50	40	30

Note that the temperature of the gas inside the pump will heat up the water and the water surface therefore will become a higher temperature than the measured temperature on the discharge side of the pump. Cavitation will therefore start at a lower temperature and the maximum discharge temperature of the water must be kept lower.

3.9 Water requirement

During operation it is normal that small amount of product will enter the pump, or the gas will react with the water which can become aggressive.

Drain the liquid separator and refill with fresh water, if the water has become aggressive.

3.10 Pipe system



The exhaust from the liquid separator will have the same zone classification as the pump's suction side

The pipes that are connected to the pump's suction and outlet sides must be at least the same dimension as the pump. The length of the pipe system affects the pump's capacity and should be calculated to account for pressure drop in longer pipe installations.

Depending on the operating pressure, longer pipe lengths may affect the pump's output. For pipe lengths greater than 20 metres, a pressure drop calculation should be made, and the pipe dimensions should be increased so that the pressure loss is held to an acceptable level.

The pipe system should be mounted so that the horizontal pipes have a min. of 1% decline back towards the liquid separator.

Table below can be used for reference values.

Connection	Length < 20 metres	Length 20–50 metres	Length 50–100 metres
Suction side	Min. DN 125	Min. DN 150	Min. DN 200
Outlet side	Min. DN 125	Min. DN 150	Min. DN 200

The outlet from the liquid separator should be led outside of the building because the outlet air is warm and humid.

With respect to the exhaust, measures must be put in place to account for damp air that may form ice in cold surroundings.

3.11 Suction filter

In installations where there is a risk of sucking foreign elements into the pump, a filter must be mounted on the pump's suction side with a maximum mesh size of 2 mm.

4 INSTALLATION AND START-UP

4.1 Securing the pump



Installation requirements must be observed, otherwise there is a risk of damage and of potential explosion

The pump must be installed on a stable foundation, which must be level and stable, so that the pump is not twisted or exposed to a profile distortion.

The pump must be installed with 4 pcs. M16 bolts, 2 pcs. in front and 2 pcs. in back. The bolts must be tightened to 180 Nm (A).

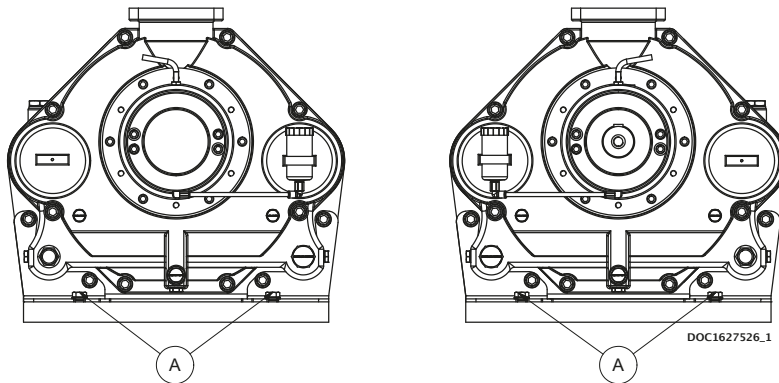

4.2 Connections to the pump



- Check for foreign objects in the pump and physical damage on pump
- Gaskets to be handled with highest degree of caution
- Gasket and sealing surfaces must be cleaned before assembly



External effects on the pump may lead to leakage and, as a result, a potential risk of explosion

Immediate before connecting the pipes, remove protective covers. Connection of the pump's suction and pressure pipe connections must be made with a gasket in between (C).

The M16 bolts must be tightened with 180 Nm (B).

In order to prevent tensions in the pump, the pipe connections (A) must be tensionless while tightening the bolts.

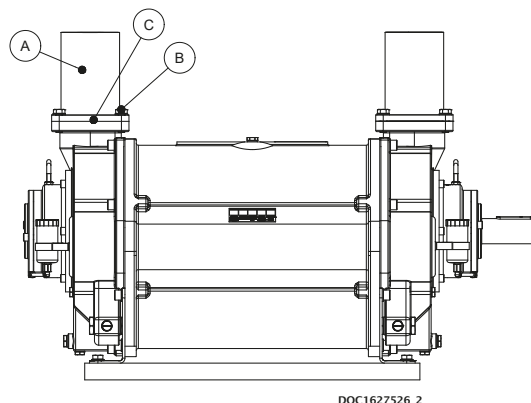

4.3 Connecting the water

The water must be connected to the pump at the hose connections, see illustration below.

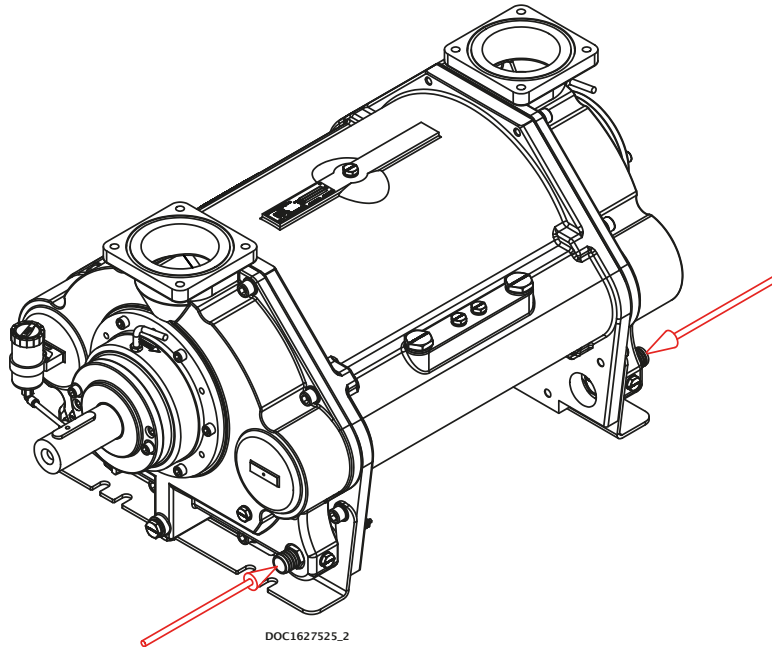

4.4 Transmission

The pump can be connected direct or through belt transmission. For belt transmission, it must be ensured that the permissible radial force is not exceeded. See specifications.

For belt transmission, note the direction of rotation, see illustration below.

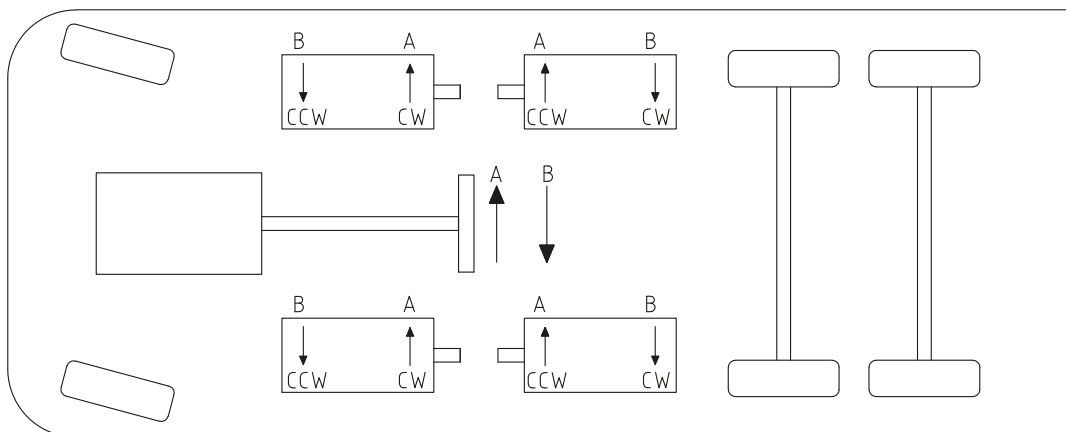

4.5 Earth connection requirements



The pump must be connected to earth to prevent static electricity. Static electricity is a potential source of ignition.

The pump must be protected from the creation of sparks in connection with static electricity, in accordance with the applicable regulations for use in the current categories.

The pump is prepared for earth connection with an M8 bolt.

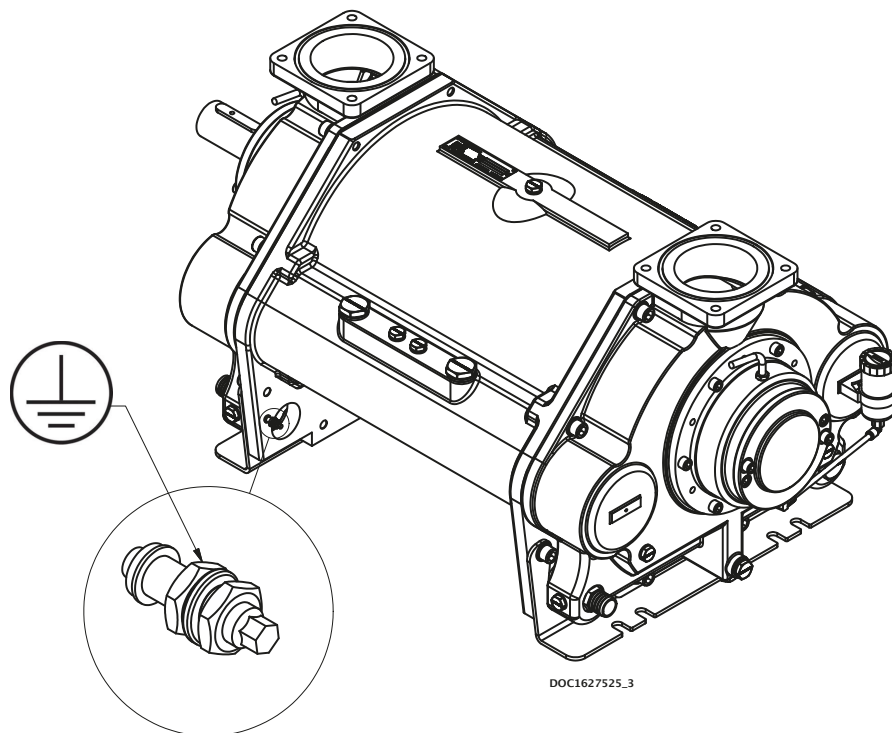

4.6 Prior to start-up



- Do not start the pump without water, as this will damage the mechanical shaft seals
- Do not start the pump if it is completely filled with water
- Do not start the pump before the grease cartridges have been activated, as this can damage the pump (if equipped)
- Stop the pump immediately if the rotational direction does not correspond to the directional arrow
- A failure to follow the above guidelines may result in damage to the pump

Activating the grease cartridges

Turn the handle in NDE clockwise to position 12.
 Turn the handle in DE clockwise to position 12.
 The pump has been lubricated from factory and is ready to start.



DOC3707

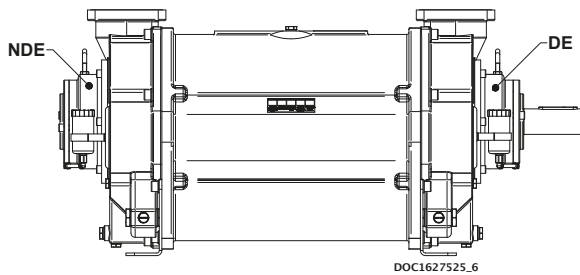

DOC1627525_6

4.7 Direction of rotation

Check the direction of rotation by briefly starting the pump.

The direction of rotation of the rotor must correspond to the direction arrow!

Below left, a right-side pump is shown which has a clockwise direction of rotation (CW)

Below right, a left-side pump is shown which has a counter-clockwise direction of rotation (CCW)

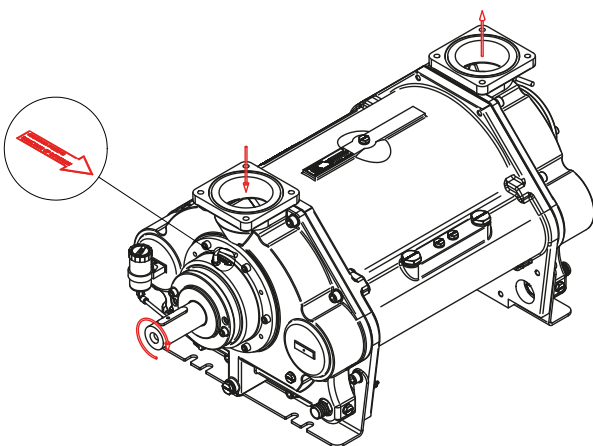

DOC1627525_7

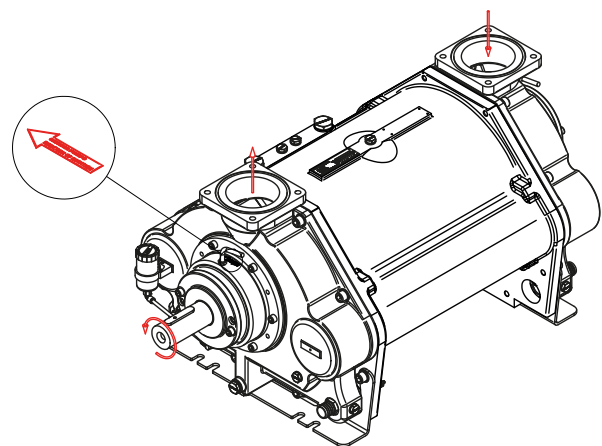

DOC1627527_1

5 SERVICE, OPERATION, MAINTENANCE AND INSPECTION INTERVALS



A failure to observe the inspection intervals described in table below may result in damage to the pump and a potential risk of explosion

Section	Operation	Interval
5.1	Inspection of bearings	Daily
5.2	Visually inspect for leakage	Weekly
5.3	Drain liquid separator and pump to remove contaminants	Daily
5.4	Check grease cartridges	Weekly
5.5	Inspection of ATEX safety device	Monthly
5.6	Inspection and cleaning (if necessary) of water supply pipe	Monthly
5.7	Calibration of ATEX safety device	Annually
5.8	Overhaul of pump	10,000 duty hours
5.9	Winterization	When below 0°C
6	Troubleshooting	As required

5.1 Inspection of bearings

The bearings of pump must be inspected once a day.

Be alert of unfamiliar sounds from bearing.

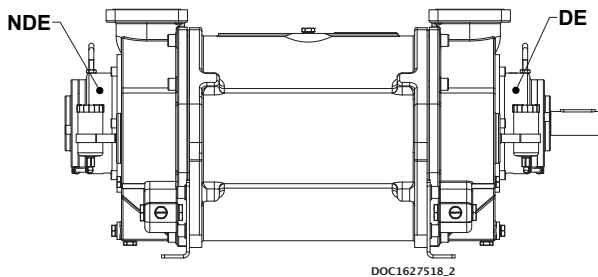

5.2 Inspecting for leakage

The pump and pipe system around the pump must be inspected for leakage once a week. The inspection must be performed when the pump is both operating and idle. Any leaks must be repaired before operation may continue.

5.3 Draining the liquid separator and the pump

While the pump is stopped, the liquid separator must be drained to remove contaminants. Drain the pump in C₁ or C₂, see chapter 2.5.

5.4 Check grease cartridges



To prevent electrostatic discharge in hazardous areas, only wet cleaning is permitted. Appropriate measures must be taken to prevent electric discharge.

Automatic lubrication must be inspected and replaced as needed.

When the pump is commissioned for the first time, the cartridges must be activated by turning the arrow in the clockwise direction.

The cartridge is set to 12, which corresponds to an emptying time of 12 months. The cartridge must be replaced when empty.

It is only allowed to use automatic lubricator of type **LAGD 125/WA2**.



5.5 Inspection of ATEX safety device



ATEX safety device must be inspected in accordance with table to ensure proper functionality. A failure to perform the required inspections will result in the discontinuation of the pump's approval.

Safety devices to be inspected in accordance with applicable regulations.

The components that make up the safety device can be found in the system layout.

5.6 Inspection and cleaning of water supply pipe

The pipe connection between the liquid separator and pump must be inspected at least once a month, and any contaminants must be removed.

5.7 Calibration of ATEX safety device

The flow and level meter must be calibrated once a year in accordance with the applicable requirements. The pump may not be started before the instruments have been re-installed.

5.8 Overhaul of pump

The pump must be serviced after 10,000 duty hours. This is done by sending the pump to Samson Pumps, or approved and certified partner, upon agreement. The pump must be cleaned before shipment.

Repairs carried out on ATEX pumps may only be performed by Samson Pumps, or approved and certified partner. If this requirement is not observed, and the pump's seal is broken, the pump's declaration of conformity is not valid and Samson Pumps is no longer responsible for any resulting consequences.

5.9 Winterization

If the pump needs to be used at a temperature below freezing point of the water, it is necessary to protect the water from freezing by adding anti freeze liquid.

6 TROUBLESHOOTING

Problem	Cause	Effect	Corrective measure
The pump is unable to create a vacuum	<ul style="list-style-type: none"> • Water control valve is closed • The pump is not receiving enough water • The temperature of the water is too high 	<ul style="list-style-type: none"> • Reduced output • The pump can become damaged during cavitation 	<ul style="list-style-type: none"> • Check water control valve • Check the water supply • Stop the pump and wait until the temperature has dropped to a sufficient level, or lower the temperature of the water inlet
The start-up power is too high	<ul style="list-style-type: none"> • Too much water in the pump prior to start-up 	<ul style="list-style-type: none"> • Noise at start-up and possible overload of the power supply 	<ul style="list-style-type: none"> • Check the stop valves in the water supply for leakage
Noise during operation	<ul style="list-style-type: none"> • Cavitation 	<ul style="list-style-type: none"> • Severe damage to the pump and potential risk of breakdown 	<ul style="list-style-type: none"> • Increase the suction pressure or lower the temperature of the water
Leakage from the bearing housing's drain holes	<ul style="list-style-type: none"> • Damaged shaft seal 	<ul style="list-style-type: none"> • Bearings may become damaged • Potential risk of explosive gas leak 	<ul style="list-style-type: none"> • Stop the pump and contact the manufacturer

7 SPARE PARTS AND TOOLS

7.1 Marking and identification

The pump is equipped with an identification plate as shown below.

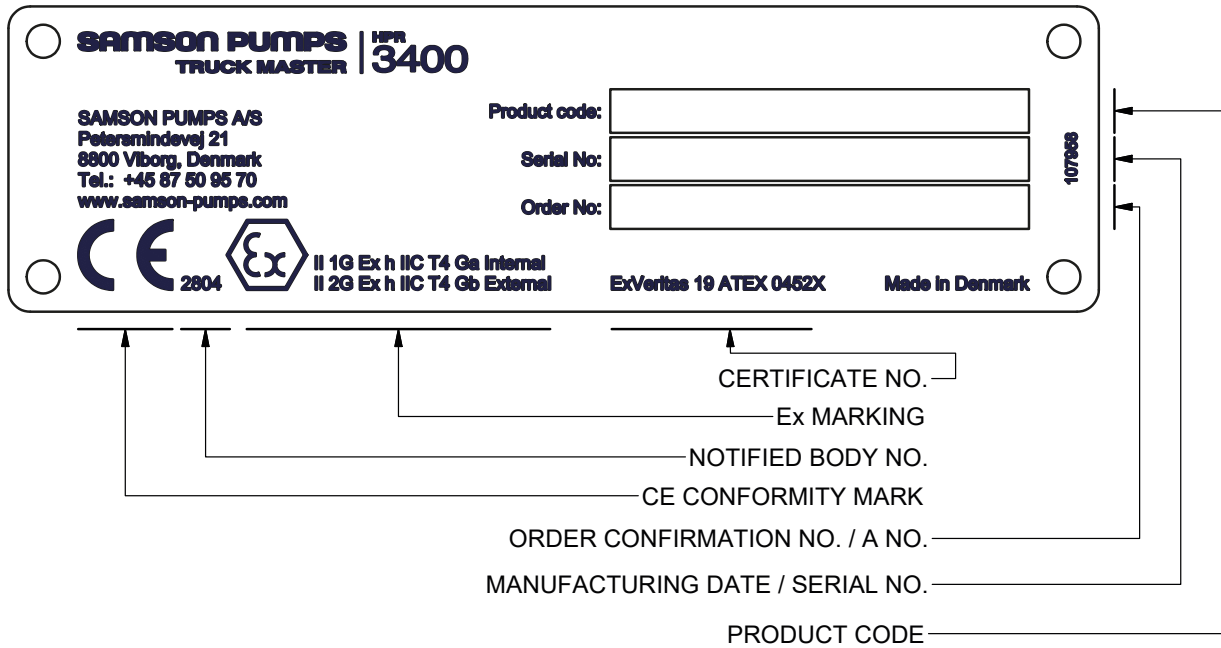

Configuration example:

TM 3400 R 0 S S B 1 0 T X5

- Type: ←
- Model: ←
- Rotation: ←
- Rotor type: ←
- Pump housing: ←
- Shell: ←
- Flow plates: ←
- Generation of pump: ←
- Gaskets: ←
- Colour: ←
- Documentation: ←

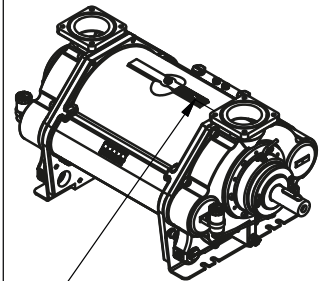

Location of ID plate

DOC107958D

7.2 How to order

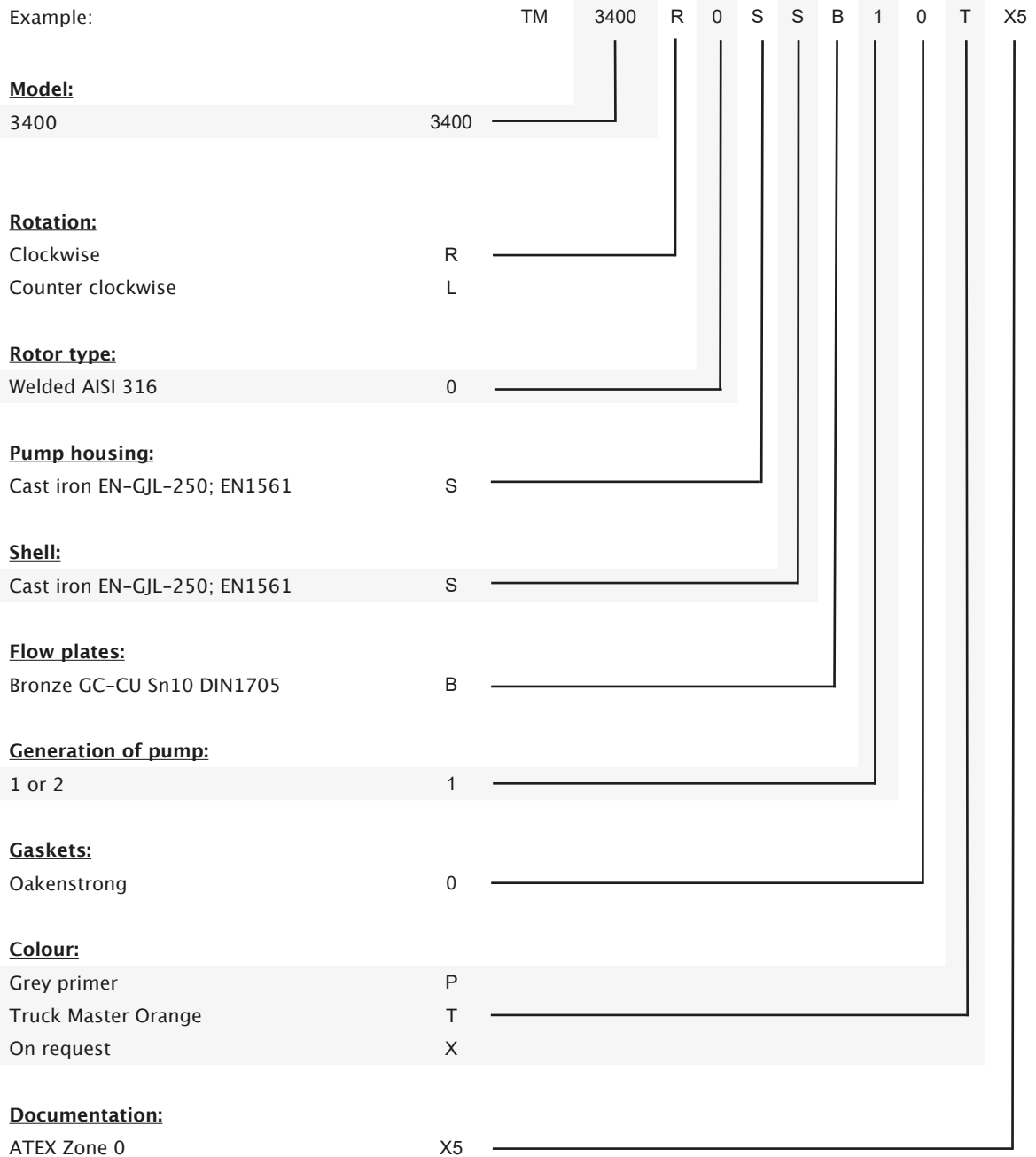

7.3 Spare parts - GENERATION 1

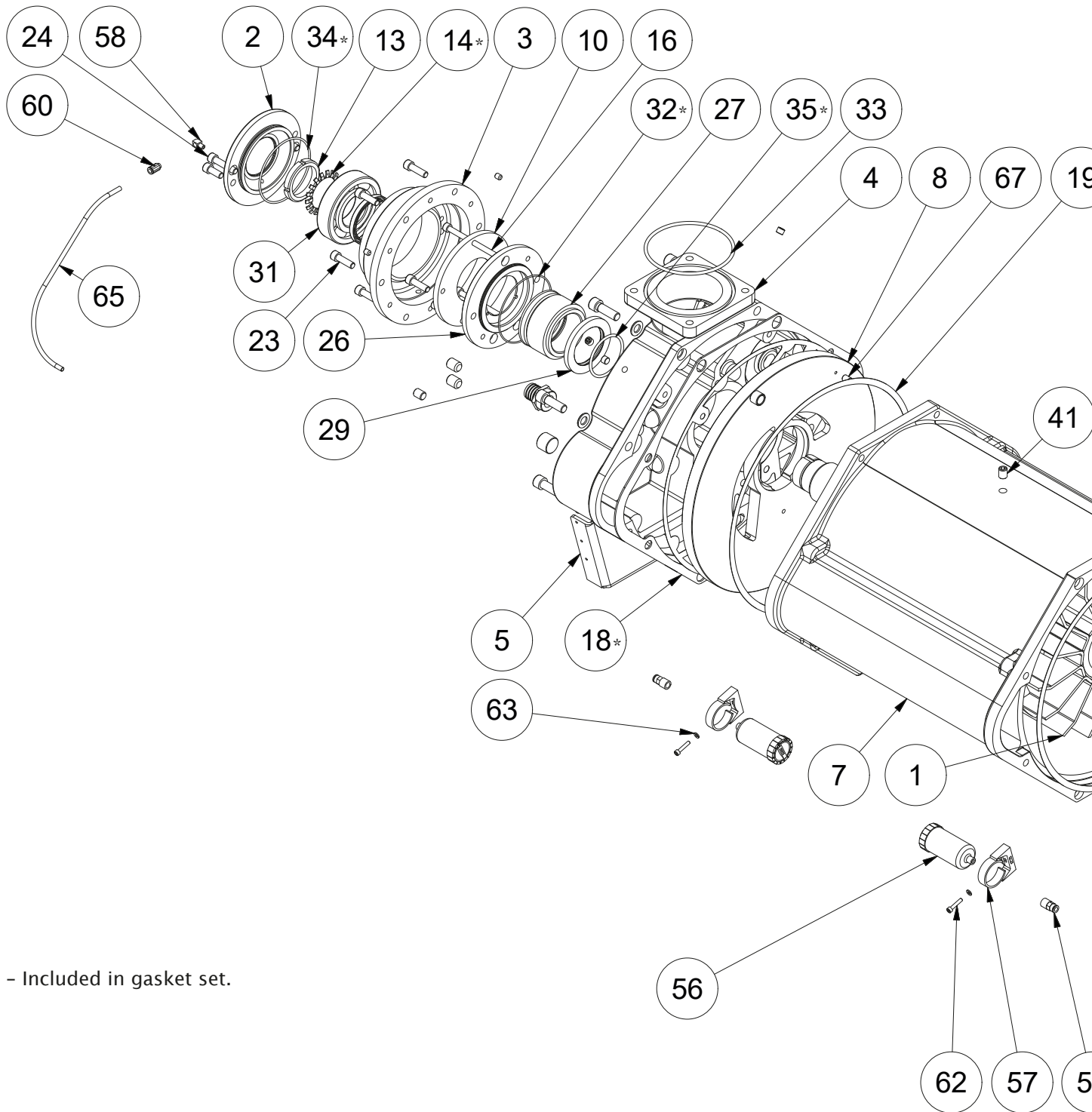

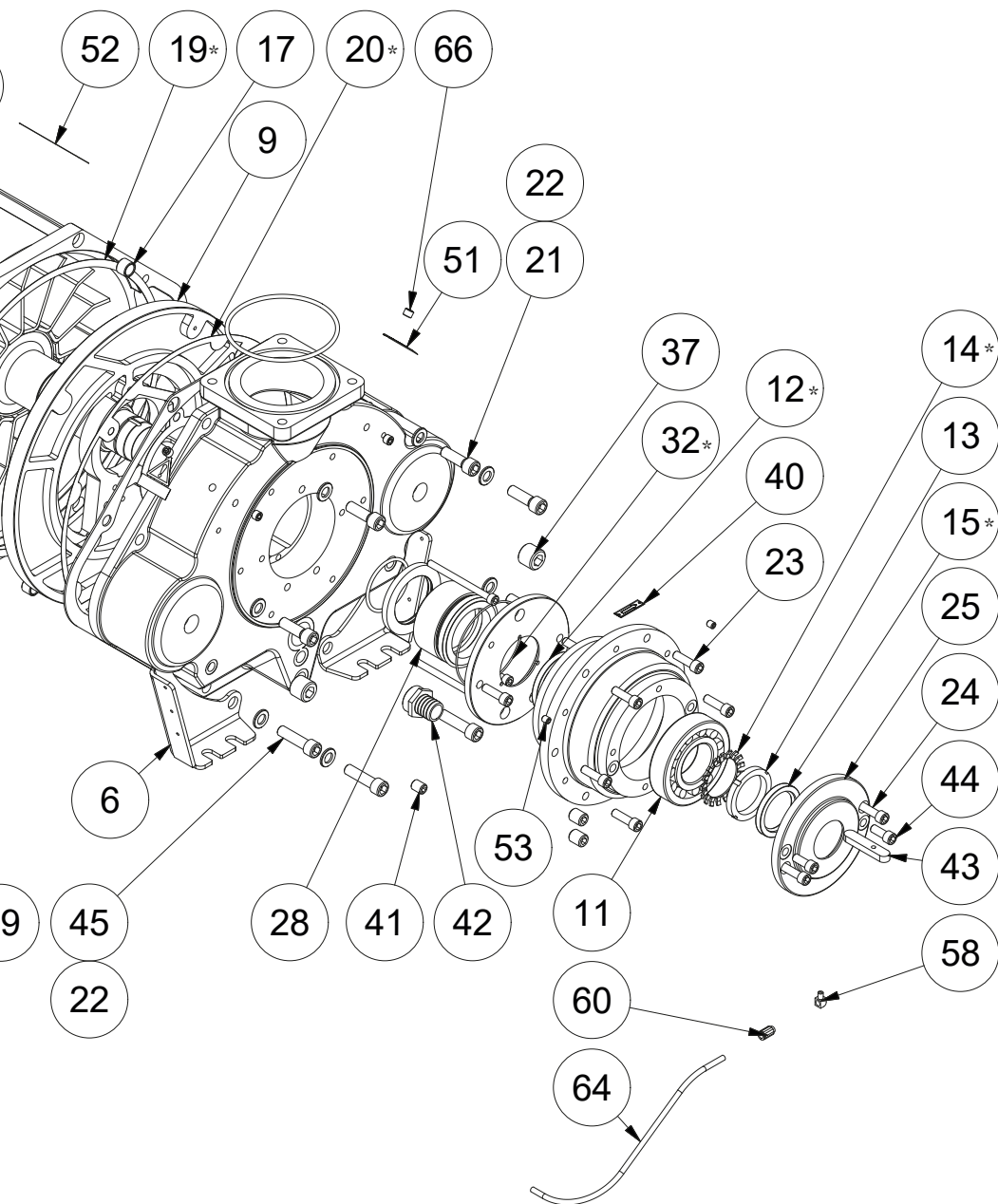

DOC1627439

Pos.	Part number	Description	Qty.	Material
1*	1620266	Rotor R	1	SS EN 1.4418 / AISI 316L
	1620270	Rotor L	1	SS EN 1.4418 / AISI 316L
2	1620181	Bearing cover NDE	1	Cast iron EN-GJL-250, EN 1561
3	1620179	Bearing housing	2	Cast iron EN-GJL-250, EN 1561
4	1620173	Pump housing	2	Cast iron EN-GJL-250, EN 1561
5	1620060	Foot bracket	2	Steel St. 37
6	1620059	Foot bracket	2	Steel St. 37
7	1620177	Shell	1	Cast iron EN-GJL-250, EN 1561
8	1620229	Flow plate	1	Bronze CuSn10-C EN 1982
9	1620231	Flow plate	1	Bronze CuSn10-C EN 1982
10	1620036	Rear cap	2	SS AISI 304
11	930000297	Roler bearing spherical	1	Chrome steel W.Nr. 1.3505
12	1620208	Gasket set Truck Master 3400	1	-
13	930200022	Shaft nut	2	Steel GB/T 8162-Q
14	1620208	Gasket set Truck Master 3400	1	-
15	1620208	Gasket set Truck Master 3400	1	-
16	910300455	Allen screw	6	Steel DIN 912 FZB
17	1620203	Bush	4	Sintered Bronze DIN 1850
18	1620208	Gasket set Truck Master 3400	1	-
19	1620208	Gasket set Truck Master 3400	1	-
20	1620208	Gasket set Truck Master 3400	1	-
21	910300102	Allen screw	8	Steel DIN 912 FZB
22	910100022	Washer	16	Steel DIN 125B FZB
23	910300076	Allen screw	16	Steel DIN 912 FZB
24	910300080	Allen screw	4	Steel DIN 912 FZB
25	1620182	Bearing cover DE	1	Cast iron EN-GJL-250, EN 1561
26	1620052	Retainer	2	SS AISI 316
27	922000259	Mechanical shaft seal	2	Viton / AISI 316 / Carbon
29	1620193	Stop ring	2	SS W.Nr. 1.4404
31	930000296	Ball bearing	1	Chrome steel W.Nr. 1.3505
32	1620208	Gasket set Truck Master 3400	1	-
33	922100330	O-ring	2	Rubber NBR
34	1620208	Gasket set Truck Master 3400	1	-
35	1620208	Gasket set Truck Master 3400	1	-
36	910300184	Plug	4	Steel DIN 906
37	910300182	Plug	4	Steel DIN 906

* -See section 7.1 for identification of pump.

Pos.	Part number	Description	Qty.	Material
40	-	Direction arrow	1	Aluminum
41	910300188	Plug	5	Steel DIN 906
42	925000477	Hose nipple	3	Brass
43	915000196	Parallel key	1	Steel DIN 6885A
44	910300072	Allen screw	4	Steel DIN 912 FZB
45	910000480	Allen screw	8	Steel DIN 912 FZB
46	925200063	Elbow	1	SS AISI 316
47	927000161	Hose	0,4 m	Rubber EPDM
48	925000712	Barrel nipple	2	SS AISI 316
49	925000788	Tee	1	SS AISI 316
50	1620257	Service liquid supply pipe	1	SS AISI 304
51	1624020	Sticker Warning!	2	Plastic foil FasCal 400
52	-	Identification plate	1	SS AISI 316
53	910300281	Plug	4	Steel DIN 906
54	925000842	Pipe clamp	2	Plastic PA
55	910300471	Allen screw	4	SS AISI 316
56	915000225	Automatic lubricator LAGD 125/WA2	2	Plastic PA6 / grease
57	915000232	Clamp for automatic lubricator	2	Plastic PA6
58	944600173	Elbow	2	Steel S235
59	915000214	Push-in nipple	2	Brass
60	944600239	Push-in nipple	2	Brass
61	918000276	Spring band hose clip	4	Steel CK75
62	910300448	Allen screw	2	SS AISI 316
63	910100125	Washer	4	SS AISI 316
64	915000217	Plastic pipe	0,1 m	Plastic PA6
65	915000217	Plastic pipe	0,1 m	Plastic PA6
66	910300185	Plug	8	Steel DIN 906
67	910300183	Plug	2	SS AISI 316

7.4 Spare parts - GENERATION 2

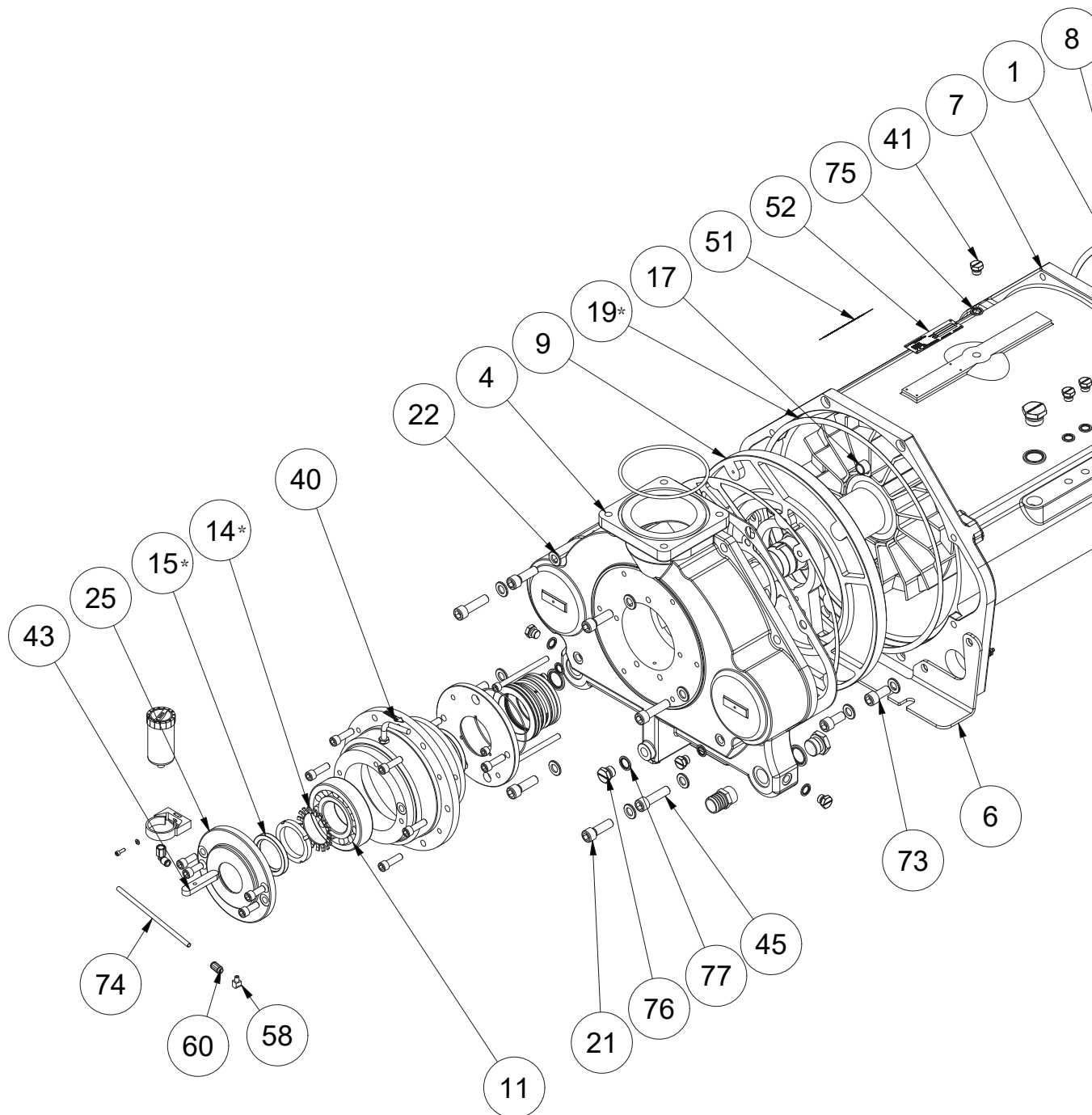

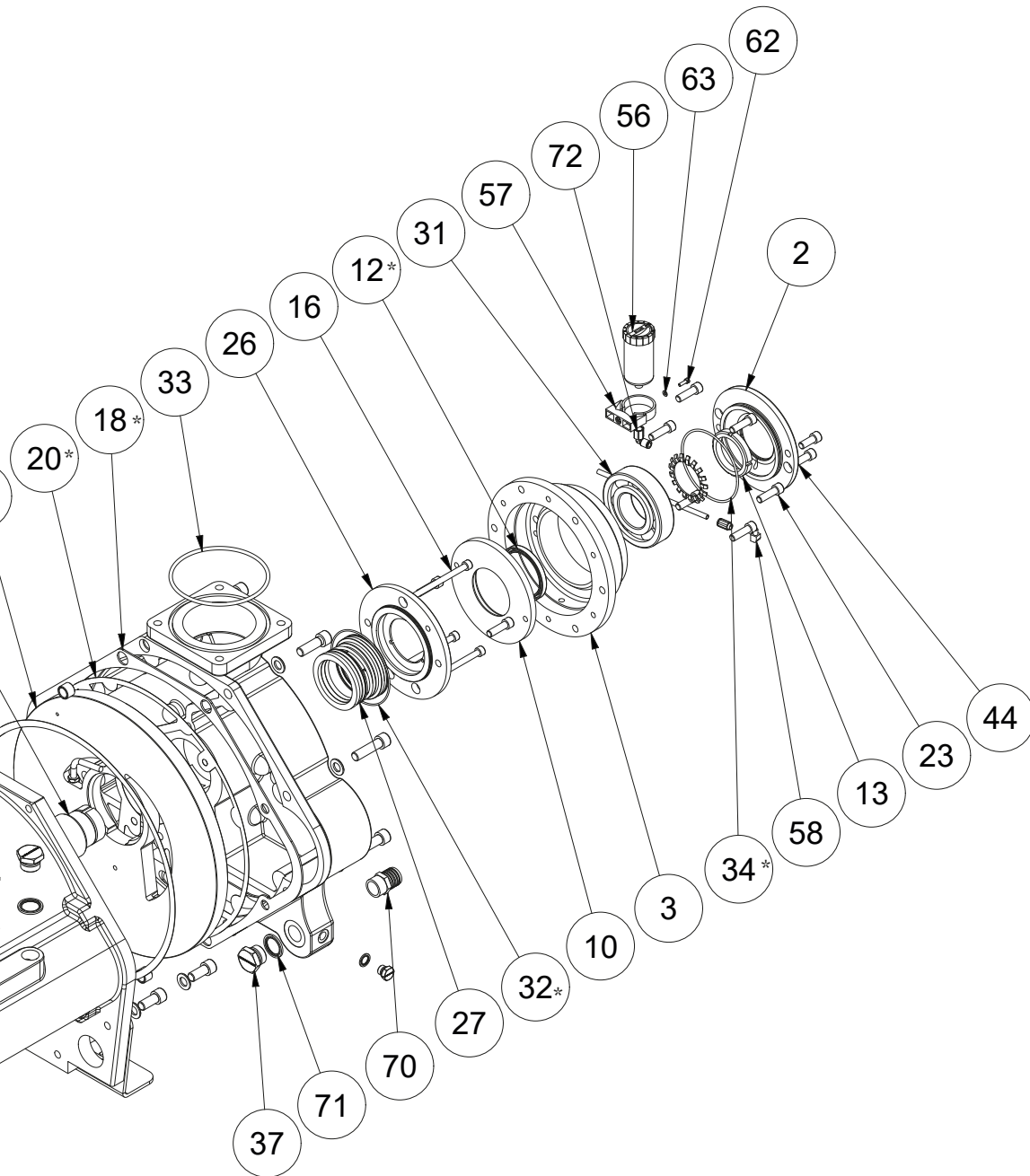

* - Included in gasket set.

Pos.	Part number	Description	Qty.	Material
1*	1620284	Rotor R	1	Stainless steel
	1620287	Rotor L	1	Stainless steel
2	1620181	Bearing cover NDE	1	Cast iron
3	1620179	Bearing housing	2	Cast iron
4	1620274	Pump housing	2	Cast iron
6	1620303	Foot bracket	2	Stainless steel
7	1620276	Shell	1	Cast iron
8	1620229	Flow plate NDE	1	Bronze
9	1620231	Flow plate DE	1	Bronze
10	1620036	Rear cap	2	Stainless steel
11	930000297	Roler bearing spherical	1	Steel
12	1620208	Gasket set Truck Master 3400	1	-
13	930200022	Shaft nut	2	Steel
14	1620208	Gasket set Truck Master 3400	1	-
15	1620208	Gasket set Truck Master 3400	1	-
16	910300479	Allen screw	6	Steel
17	1620203	Bush	4	Sintered Bronze
18	1620208	Gasket set Truck Master 3400	1	-
19	1620208	Gasket set Truck Master 3400	1	-
20	1620208	Gasket set Truck Master 3400	1	-
21	910300480	Allen screw	8	Steel
22	910100148	Washer	24	Steel
23	910300482	Allen screw	16	Steel
25	1620182	Bearing cover DE	1	Cast iron
26	1620052	Retainer	2	Stainless steel
27	922000277	Mechanical shaft seal	2	Viton / AISI 316 / Carbon
31	930000296	Ball bearing	1	Steel
32	1620208	Gasket set Truck Master 3400	1	-
33	922100330	O-ring	2	Rubber
34	1620208	Gasket set Truck Master 3400	1	-
37	1634812	Plug	7	Stainless steel
40	-	Direction arrow	1	Plastic foil
41	1634809	Plug	15	Stainless steel
43	915000196	Parallel key	1	Steel
44	910300074	Allen screw	8	Stainless steel
45	910300466	Allen screw	8	Stainless steel
51	1624074	Label	1	Plastic foil
52	-	Identification plate	1	Stainless steel

* -See section 7.1 for identification of pump.

Pos.	Part number	Description	Qty.	Material
56	915000225	Automatic lubricator LAGD 125/WA2	2	Plastic / grease
57	915000232	Clamp for automatic lubricator	2	Plastic
58	944600173	Elbow	2	Brass
60	944600239	Push-in nipple	2	Brass
62	910300487	Allen screw	2	Stainless steel
63	910100191	Washer	2	Stainless steel
70	925000478	Hose nipple	1	Brass
71	922000267	Bonded seal	7	Stainless steel
72	944600240	Push-in elbow 90°	2	Brass
73	910300488	Allen screw	8	Stainless steel
74	915000217	Plastic pipe	1 m	Plastic
75	922000269	Bonded seal washer	15	Steel
76	1634810	Plug	2	Stainless steel
77	922000268	Bonded seal	2	Stainless steel
78	910300477	Earth threaded stud.	1	Stainless steel

7.5 Gasket set

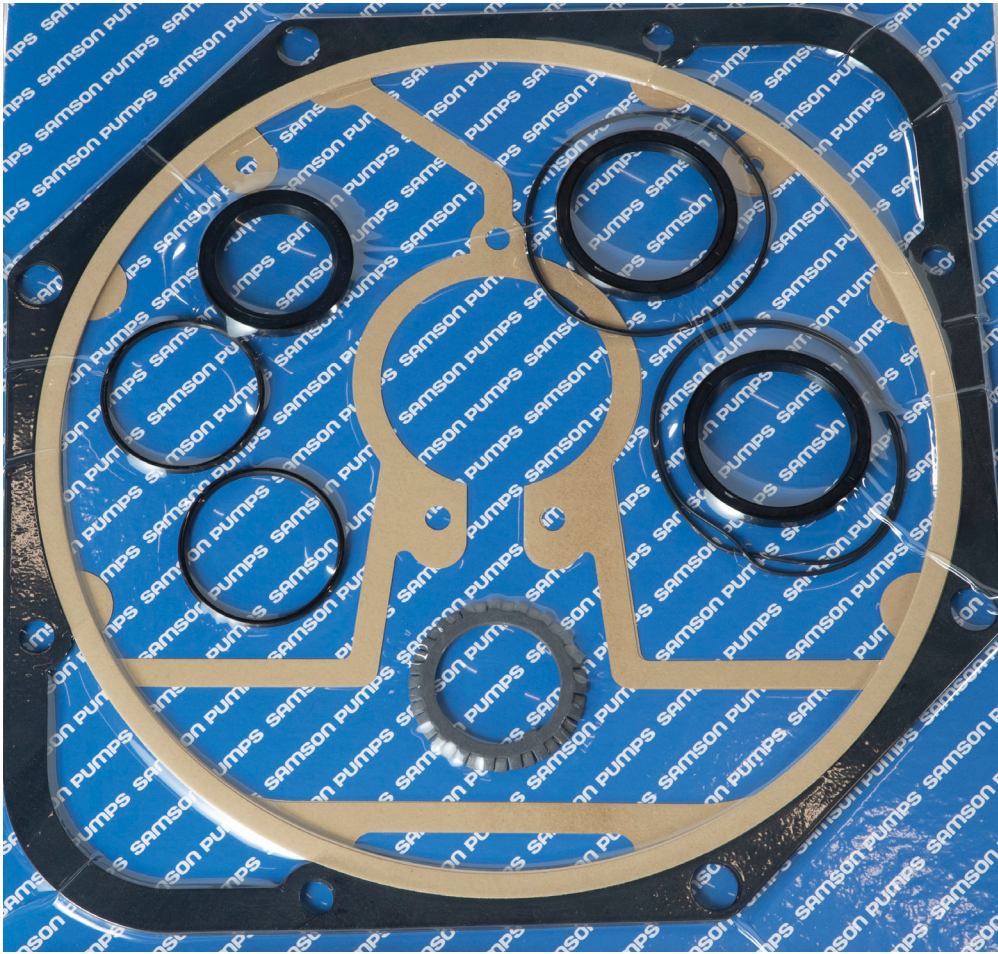

DOC11587A

Pos.	Part number	Description	Qty.	Material
12	922200155	Radial shaft seal 80x100x10	2	Rubber NBR DIN 3760A
14	930200025	Lock washer	2	Steel DC01 SS-EN 10130
15	922200075	Radial shaft seal 62x85x10	1	Rubber NBR DIN 3760A
18	1620202	Gasket for pump housing / shell 3 mm	2	Rubber NBR
	1620072	Gasket for shell / flow plate 0,5 mm	2	Paper Oakenstrong
19	1620233	Gasket for shell / flow plate 0,8 mm	2	Paper Oakenstrong
	1620171	Gasket for shell / flow plate 1,0 mm	2	Paper Oakenstrong
20	1620183	Gasket for pump housing / flow plate 0,4 mm	2	Paper Oakenstrong
32	922100331	O-ring Ø134x2,5	2	Rubber NBR
34	922100332	O-ring Ø129,77x3,53	1	Rubber NBR
35	922100348	O-ring Ø80x5	2	Rubber NBR

See spare parts drawing (DOC1627439 OR DOC1627524) for positions.

7.6 Special tool set

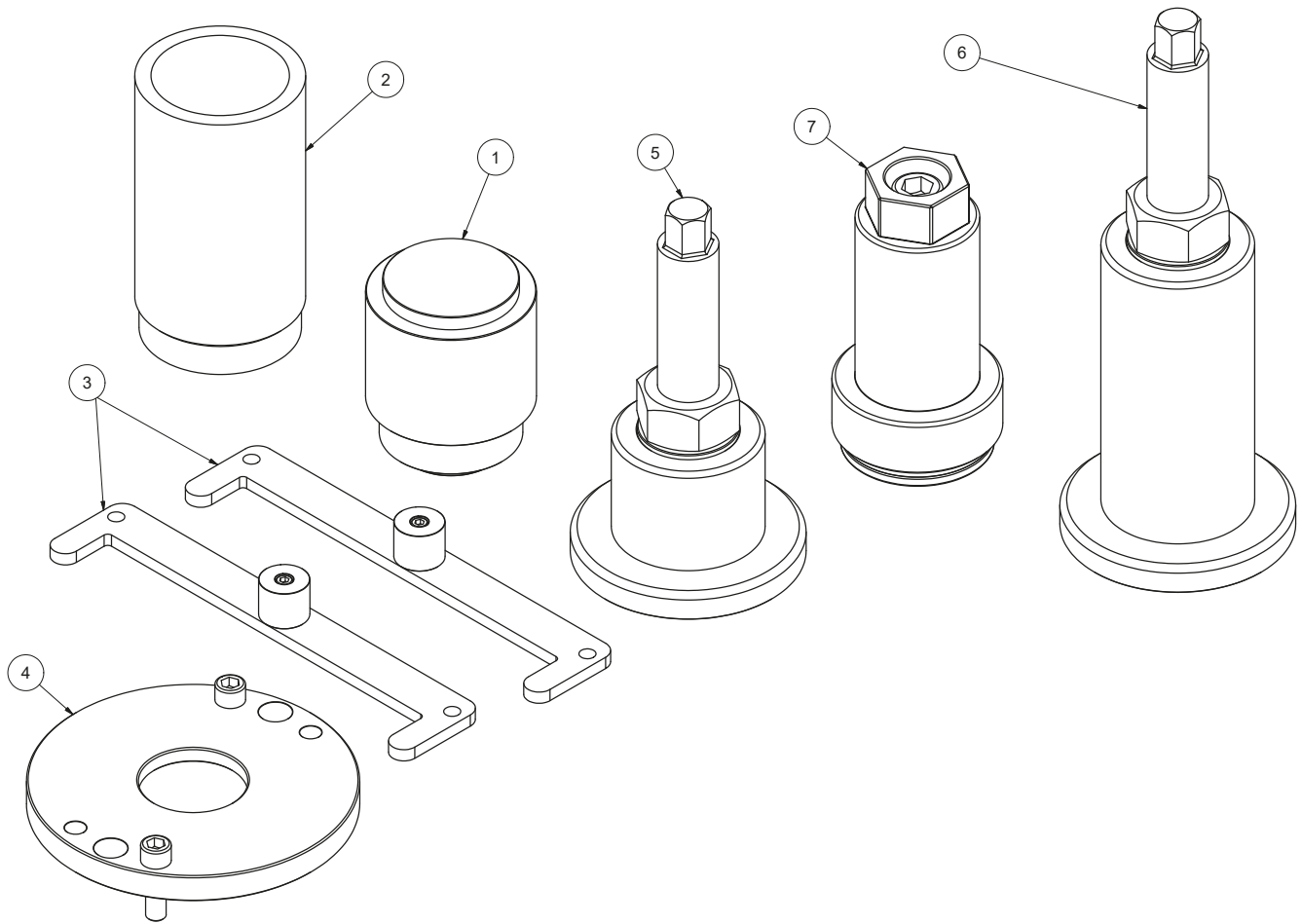

Pos.	Part number	Description	Qty.	Material
1	1629171	Mandrel radial shaft seal Ø85 + Ø100	1	Plastic POM
2	1629117	Mechanical shaft seal tool	1	Plastic POM
3	1629134	Alignment tool	2	Steel AISI 304
4	1629173	Machined bearing cap set	1	Steel S235
5	1629115	Bearing mounting tool set NDE	1	Steel / Brass / Al
6	1629116	Bearing mounting tool set DE	1	Steel / Brass / Al
7	1629175	Bearing tool set	1	Steel / Al

Notes:

SAMSON PUMPS

Samson Pumps is the only company in the world to specialize in liquid ring vacuum pumps. The pumps are made in Denmark and used all around the globe.

Truck Master, Ocean Master and Industrial Series Gamma are the company's three brands. Truck Master Series is designed and optimized for the vacuum truck market. Ocean Master Series is meant for the fish industry where the pumps are usually installed onboard fishing vessels. Gamma Series is designed to handle the harshest industrial vacuum jobs.

At the core of Samson Pumps' activity is the strong belief that our liquid ring vacuum pumps must be of superlative quality for our customers to focus on what they do best. We always improve the quality and design of our pumps to better suit the vacuum units built by OEMs all around the globe.

Strength and durability are our hallmarks! Time and time again we hear from our satisfied customers that our pumps continue operating year after year and in most cases without the need for maintenance or repair. Samson Pumps is your reliable liquid ring vacuum pump supplier.