

INSTRUCTION MANUAL

LIQUID RING PUMP



ATEX APPROVED



Zone 1 Internal / Zone 1 External

TRUCK MASTER® 600

INSTRUCTION MANUAL FOR SAMSON LIQUID RING PUMP
TRUCK MASTER 600

-
- Technical data
 - Design of a system
 - System layout
 - Installation and start-up
 - Service
 - Troubleshooting

CONTENTS

1	Introduction	4
1.1	Declaration of conformity.....	4
1.2	Explanation of warning symbols.....	5
1.3	Disposal.....	5
1.4	ATEX Directive 2014/34/EU	6
1.5	Field of application.....	7
2	Technical data.....	8
2.1	Dimensions.....	8
2.2	Specifications.....	9
2.3	Power consumption and output.....	10
2.3.1	Vacuum	10
2.3.2	Pressure.....	10
2.3.3	Correction factor - Temperature	11
2.3.4	Correction factor - Wet and dry gas.....	11
2.4	Handling and transport	12
2.5	Pump storage and draining procedure.....	13
3	Design of a system	14
3.1	Function and design of a liquid separator.....	15
3.2	Air cooling with fan cooler	16
3.3	Fan cooler	17
3.4	Water consumption	18
3.5	Dome valve system	18
3.6	System layout (Zone 1/1)	19
3.7	Liquid separator.....	20
3.8	Cavitation	21
3.9	Service liquid requirement.....	21
3.10	Pipe system.....	22
3.11	Suction filter	22

4	Installation and start-up	23
4.1	Securing the pump	23
4.2	Connections to the pump	23
4.3	Connecting the service liquid	24
4.4	Transmission	24
4.5	Earth connection requirements	25
4.6	Prior to start-up	26
4.7	Direction of rotation	26
5	Service, operation, maintenance and inspection intervals	27
5.1	Inspection of bearings	27
5.2	Inspecting for leakage	27
5.3	Draining the liquid separator	28
5.4	Check grease cartridges (Category 2 pumps with grease cartridges)	28
5.5	Lubrication of bearings (Category 2 pumps without grease cartridges)	28
5.6	Inspection of ATEX safety device	29
5.7	Inspection and cleaning of service liquid's supply pipe	29
5.8	Calibration of ATEX safety device	29
5.9	Overhaul of pump	29
5.10	Inspection and cleaning of internal channels	30
5.11	Winterization	30
6	Troubleshooting	31
7	Spare parts and tools	32
7.1	Marking and identification	32
7.2	How to order	33
7.3	Spare parts	34
7.4	Gasket set	38
7.5	Special tool set	39

1 INTRODUCTION

1.1 Declaration of conformity

SAMSON PUMPS

Declaration of Conformity

Annex IIA

Samson Pumps A/S

Petersmindevej 21
DK-8800 Viborg

Hereby declares that the following products:

Liquid ring pumps

**TM3400, TM2500, TM1700, TM1600, TM600, TM350, SLP2100, SLP2700, SLP3100
OM1000, OM700, OM500, OM450, OM250**

Conforms to the following directives:

Machinery Directive 2006/42/EC

ATEX Directive 2014/34/EU

Explosion protection as follows on nameplate:

 II 2G Ex h IIC T4 Gb Internal

 II 2G Ex h IIC T4 Gb External

I hereby declare, that the machine are in conformity with the following harmonized standards:

DS/EN ISO 12100:2011	Safety of machinery - General principles for design - Risk assessment and risk reduction
DS/EN 1012-2 + A1:2009	Compressors and Pumps - Safety requirements - Part 2: Vacuum pumps
DS/EN 1127-1:2011	Explosive atmospheres - Explosion prevention and protection - part 1: Basic concepts and methodology
DS/EN ISO 80079-36:2016	Explosive atmospheres - Part 36: Non-electrical equipment for explosive atmospheres - Basic method and requirements
DS/EN ISO 80079-37:2016	Explosive atmospheres - Part 37: Non-electrical equipment for explosive atmospheres - Non-electrical type of protection constructional safety "c", control of ignition sources "b", liquid immersion "k"

The standard above only applies to the extent that it is relevant for the purpose of the pump. The product must not be used before the complete system, which it must be incorporated in, has been conformity assessed and found to comply with all relevant health and safety requirements of 2006/42/EC and other relevant directives. The product must be included in the overall risk assessment.

ATEX Conformity Certificate Number **ExVeritas 19 ATEX 0582**

Viborg, 28.04.2020



Jan S. Christiansen – Manager, Technical dept.

DOC4047F

E-Mail | info@samson-pumps.com | Samson Pumps A/S | Petersmindevej 21
Web | www.samson-pumps.com | Phone | +45 87 50 95 70 | DK-8800 Viborg

1.2 Explanation of warning symbols

Important technical and safety instructions are shown by symbols. If the instructions are not performed correctly, it can lead to personnel injuries or incorrect function of the pump.



To be used with all safety instructions that must be followed. A failure to follow the instructions may result in injuries and/or incorrect machine operation



This symbol stands for safety instructions which – if they are not observed – may lead to a risk of explosion. You must therefore always follow these instructions.

1.3 Disposal

Samson's liquid ring pump is manufactured so that most of the device can be reused/recycled.

Samson Pumps offer users of the company's pumps the option of returning used pumps to be restored or scrapped.

Alternatively, the pump must be taken apart and sorted into its separate components, by the customer (see section 7 for the pump's material).

These components must be disposed of in accordance with national regulations.

1.4 ATEX Directive 2014/34/EU

The pump may be incorporated into a larger system, if the internal atmosphere has an area classification of:
Zone 1 (for ATEX category 2 pumps)

These systems will be certified in accordance with the ATEX Directive 2014/34/EU

For the certification to be valid, the pump must be installed as described in this manual.



II 2G Ex h IIC T4 Gb X Internal

II 2G Ex h IIC T4 Gb X External

ExVeritas 19 ATEX 0452X

Explanation of symbols and characters used in ATEX marking:



The European Commission's mark for Ex products

- II Equipment group II (non-mining)
- 2 Equipment category
- G Type of explosive atmosphere (G = Gas)
- Ex Indication of equipment for use in potentially explosive atmospheres
- h Explosion protection
- IIC Gas group (explosion group)
- T4 Temperature class (T4 = 135°C)
- Gb Equipment protection level

ExVeritas 19 ATEX 0452X is the certificate number.

- X Special conditions for safe use only applies to Zone 0 liquid ring pumps.

1.5 Field of application



Inlet of foreign objects, including condensing gases can damage the pump



The pump is designed exclusively to pump gases, including atmospheric air



WARNING!
Do not operate the pump so that cavitation can occur! For further information see instruction manual for the Samson Pumps vacuum limiter

It must be ensured that the inlet gas cannot react with the service liquid and create aggressive bonds that break down the pump's components.

For other operating data, see specifications.

- The pump may only be used with media that are not aggressive to the pump's materials. See section 7.3 for components and appertaining materials.
- When using ATEX-approved pumps, refer to the marking on the pump and the areas of application specified in the ATEX Directive.

2 TECHNICAL DATA

2.1 Dimensions

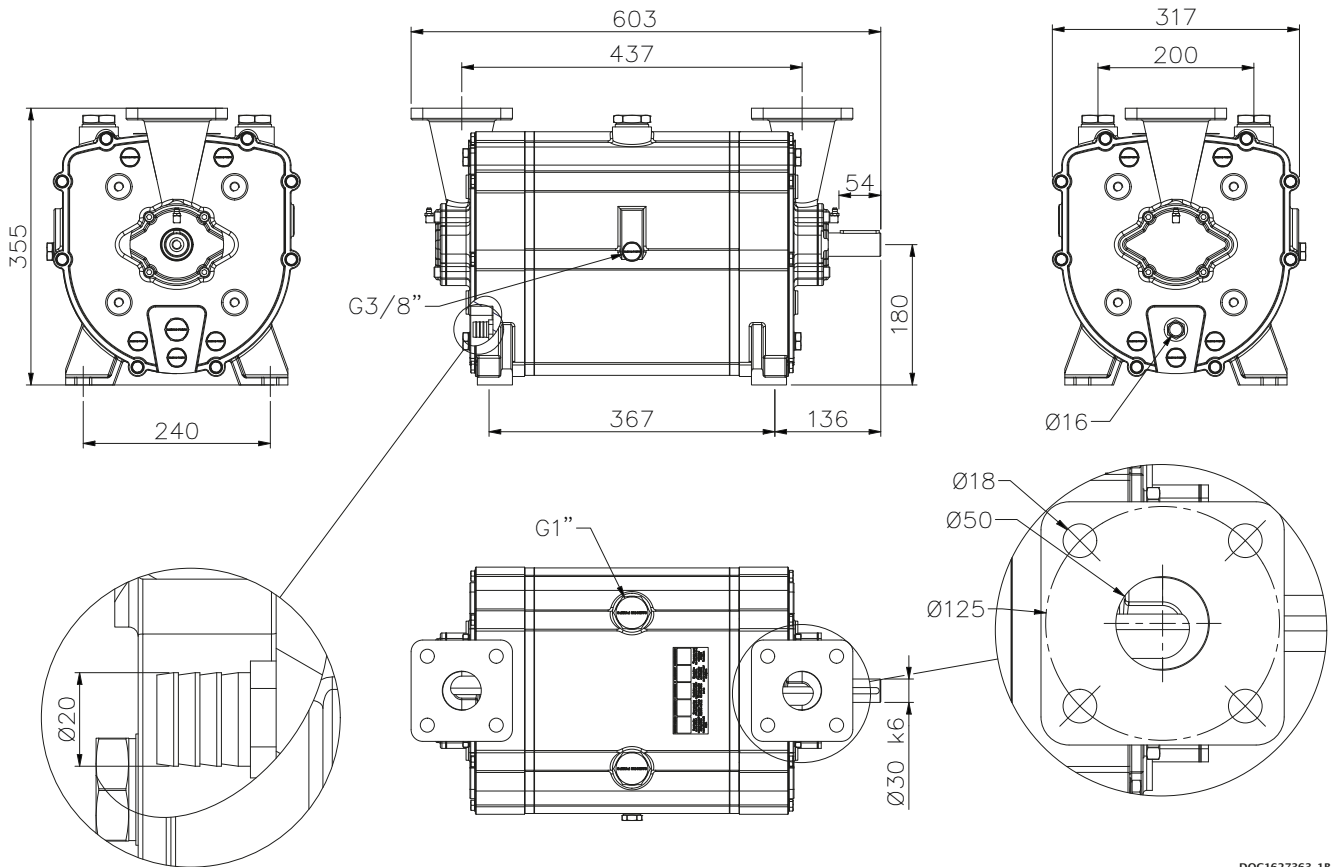

DOC1627363_1B

2.2 Specifications



A failure to meet these specifications may result in damage to the pump and a potential risk of explosion

Description		Minimum	Maximum
Ambient temperature, operation	Below 0°C – see chapter 5.11	-20°C	55°C
Ambient temperature, storage		-20°C	55°C
Humidity		-	100%
Intake temperature, suction side		-	60°C
Intake temperature, service liquid		-	60°C
Service liquid pipe connection, dimension		½"	-
Service liquid pipe connection, length		-	6 m
For all connections, it is recommended to use the pump's existing connection size as minimum size.			
Noise level		-	70 dB(A)
Water volume		-	9 L
Maximum radial load on drive shaft		-	2000 N
Heat input for cooler calculation	1500 rpm	8 kW	-
	1600 rpm	10 kW	-
	1700 rpm	11 kW	-
	1800 rpm	14 kW	-
Revolutions		1200 rpm	1800 rpm
Pressure		150 mbar abs.	1 bar(g)
Lubricating grease	Type of grease	SKF LGWA2	
	Automatic lubrication	SKF LAGD 125/WA2	
Weight		117 kg	

It is required to install liquid separator to ensure the pump is supplied as much water as needed. See System layout Zone 1/1.

* -Automatic lubrication: Zone 1/1 - Optional.

2.3 Power consumption and output

2.3.1 Vacuum

	Vacuum	[%]	80	70	60	50	40	30	20
1500 [rpm]	Flow _{Wet}	[m ³ /h]	228	329	348	368	356	423	436
	Flow _{Dry}	[m ³ /h]	171	257	303	326	327	392	407
	Consumption	[kW]	10						
	Torque	[Nm]	53						
1600 [rpm]	Flow _{Wet}	[m ³ /h]	382	411	414	430	507	524	527
	Flow _{Dry}	[m ³ /h]	285	321	360	381	465	485	493
	Consumption	[kW]	13						
	Torque	[Nm]	69						
1700 [rpm]	Flow _{Wet}	[m ³ /h]	447	455	452	547	549	563	572
	Flow _{Dry}	[m ³ /h]	333	355	393	484	504	521	535
	Consumption	[kW]	15						
	Torque	[Nm]	80						
1800 [rpm]	Flow _{Wet}	[m ³ /h]	500	494	493	583	585	604	598
	Flow _{Dry}	[m ³ /h]	373	386	429	516	537	559	559
	Consumption	[kW]	18						
	Torque	[Nm]	96						

2.3.2 Pressure

	Pressure	[bar(g)]	0	0.25	0.5	0.75	1
1500 [rpm]	Flow	[m ³ /h]	396	385	382	378	376
	Consumption	[kW]	9	11	15	18	22
	Torque	[Nm]	57	70	92	115	140
1600 [rpm]	Flow	[m ³ /h]	450	448	418	405	384
	Consumption	[kW]	11	12	17	20	23
	Torque	[Nm]	66	72	101	119	137
1700 [rpm]	Flow	[m ³ /h]	488	449	418	414	402
	Consumption	[kW]	7	13	18	21	26
	Torque	[Nm]	37	73	101	118	146
1800 [rpm]	Flow	[m ³ /h]	496	462	459	448	445
	Consumption	[kW]	10	14	21	23	28
	Torque	[Nm]	53	74	111	122	149

The data Flow_{Dry} is based on the following parameters:

- Air temperature 20°C
- Service liquid temperature 15°C
- Test performed with dry air and 1,013 mbar absolute pressure
- Tolerance ±10%

2.3.3 Correction factor – Temperature



Suction pressure and service liquid temperature to be adjusted in such way that cavitation cannot occur

When the temperature of the service liquid exceeds 15°C, the pump's capacity will be affected with respect to the specified values.

To determine the output at a higher temperature, the correction factor can be used.

Capacity at service liquid temperature higher than 15°C :

$$Q_{t>15} = Q_{15} \times K_1$$

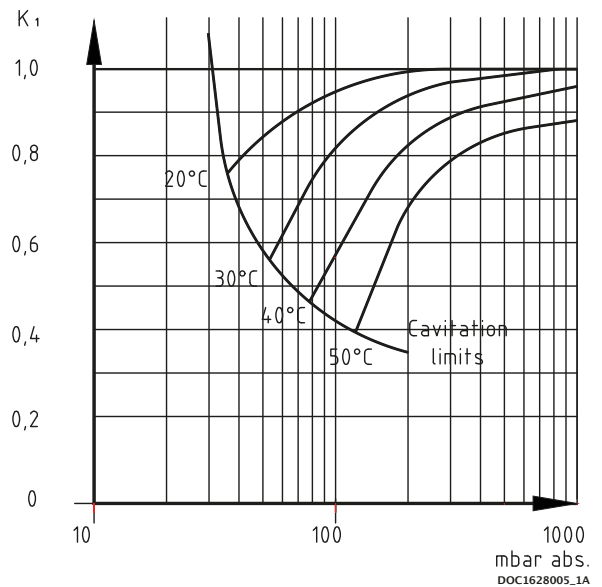

2.3.4 Correction factor – Wet and dry gas

Normal atmospheric air contains water vapor. In this case water will condense inside the pump and will create a higher flow.

Below you can find a correction factor table for the performance based on condensing gas with an inlet temperature of 50°C 100% saturated and service liquid temperature of 15°C.

Suction pressure % Vacuum	80	70	60	50	40	30	20
Correction factor wet gas K_{Wet}	1,34	1,28	1,15	1,13	1,09	1,08	1,07

The performance of the pump can thereby be calculated as:

$$V_{Wet} = V_{Dry} \times K_{Wet}$$

2.4 Handling and transport



The pump must not be used if it is damaged or the identification plate is missing
ATEX marking must correspond to the area the pump is operating in

The pump must be transported in such way that it is not exposed to vibrations and impacts that can overload the bearings.

The pump must be inspected for damages upon delivery. If the pump is damaged, it must not be used and the damage must be reported to the manufacturer.

Ensure that the pump's identification plate is intact and that the marking of the pump corresponds to its use.

The pump must only be handled using approved lifting eyes, in accordance with nationally applicable regulations and only in a vertical motion.

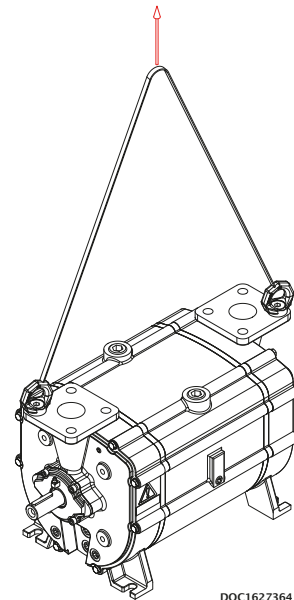

DOC1627364_1

The pump can be transported in the following ways:

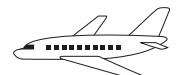

DOC11093A

2.5 Pump storage and draining procedure



A failure to comply with the requirements for storing the pump may result in internal damage to the device



If the temperature is below freezing point of the service liquid, it could damage the pump. Under these conditions, the pump must be drained completely.



All plugs and protective covers must be fitted during storage.

The pump's service liquid is drained on delivery, and the pump can be immediately stored in accordance with the technical specifications.

After operation, the pump can be stored for 30 days without further action.

If the pump remains out of operation for a longer period of time after use, its service liquid must be drained, and the liquid supply to the pump must be shut off.

When emptying the pump, it is important that all chambers inside the pump are emptied.

The pump can be fitted with valves in the draining connections. See below.

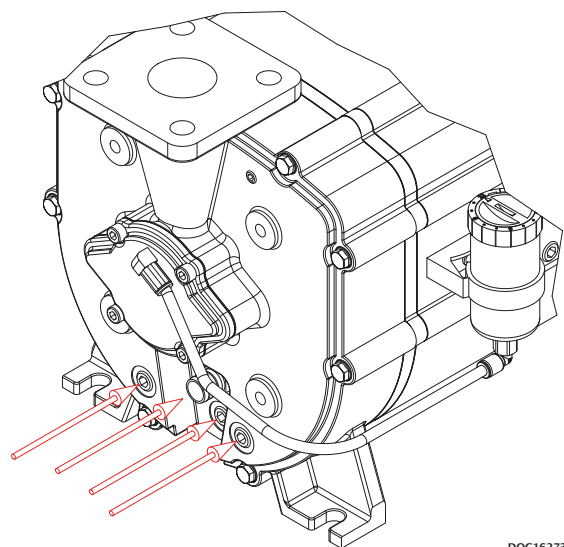
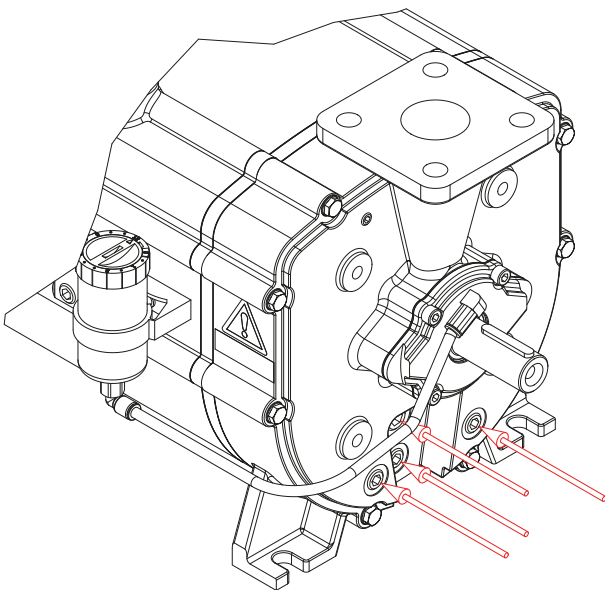

DOC1627365

3 DESIGN OF A SYSTEM

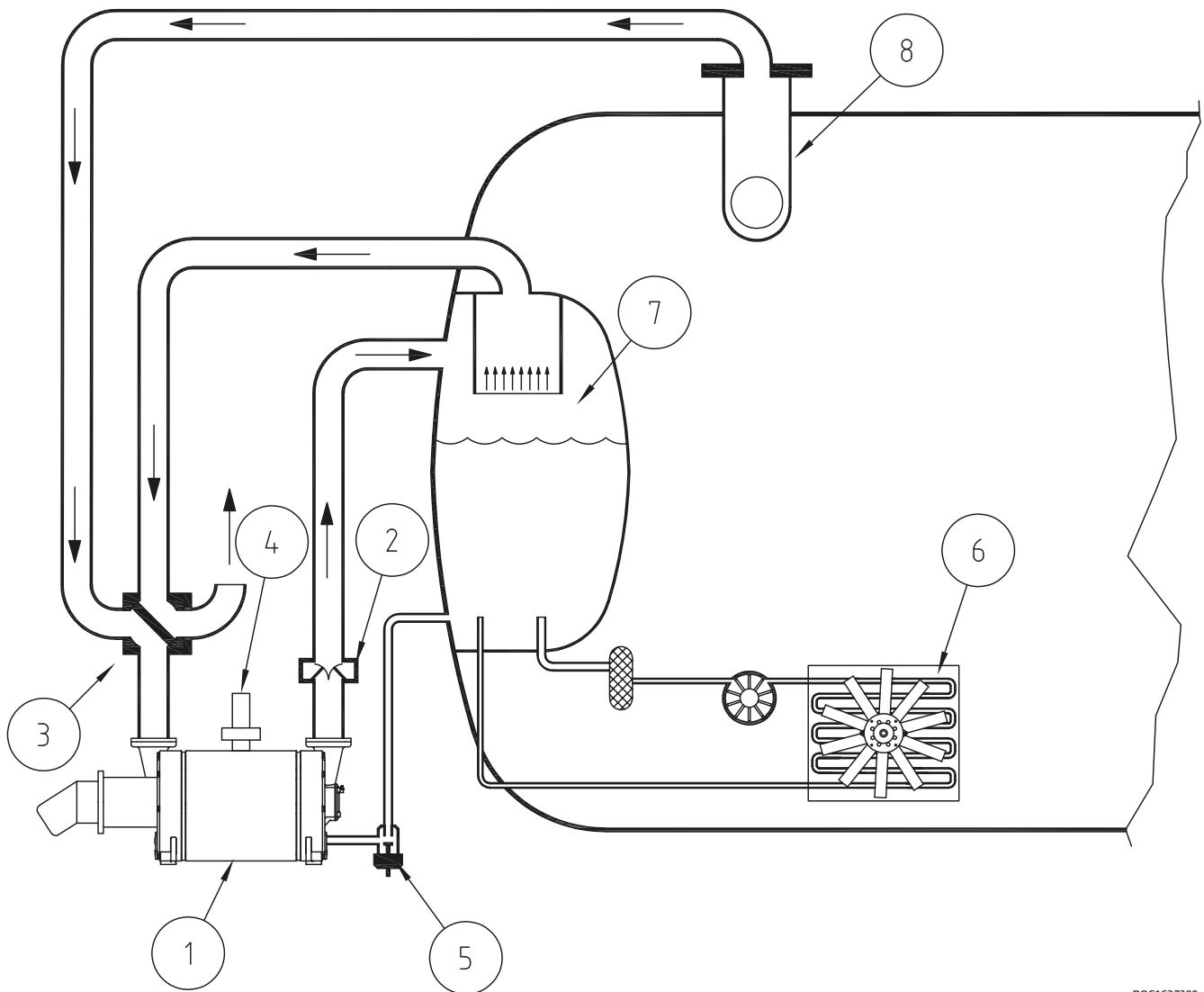

DOC1627390

Pos.	Description
1	Liquid ring pump
2	Non return valve
3	4-way valve
4	Vacuum limiter
5	Service liquid valve
6	Fan cooler
7	Liquid separator
8	Dome valve

3.1 Function and design of a liquid separator

Together with the air there will be a water flow out of the pump up to 6 m³/h.

The water will be separated from the air in the liquid separator.

Depending of the size of particles, water will be carried with the water when the air velocity is more than 3-4 m/s.

The inlet speed to the separator can be more than 50 m/s and this must be reduced to 3 m/s.

Below you find an illustration showing how to reduce the speed and control that no water will be in contact with the high velocity air stream. The round velocity reducer can be placed inside any tank geometry.

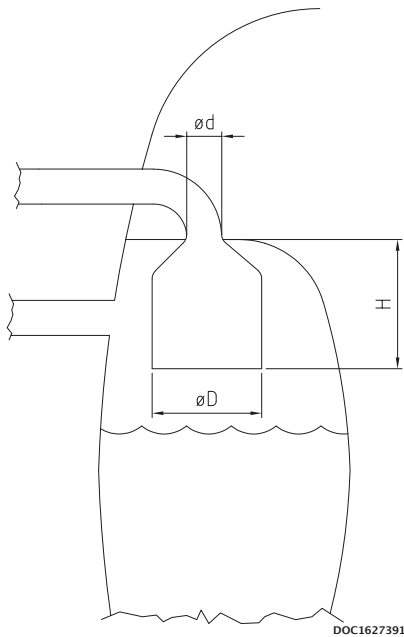

Air flow [m ³ /h]	øD minimum [mm]
600	270
550	255
500	240
450	230
400	220
350	200

øD so the velocity is below 3 m/s

H=4 to 6*ød depending on the geometry. A smooth diameter conversion will give a low factor.

3.2 Air cooling with fan cooler

Compression of air inside the liquid ring pump will create heat that is transferred to the service liquid. Therefore, it can be necessary to install a fan cooler depending on the expected use, the climate etc. The time it takes to heat up the water also depends on for example ambient temperature, suction pressure, amount of water and the cooling effect in the truck itself.

The operation temperature will go up until there is a balance between the heat input and the heat output. So basically, there are only two things that can lower the operation temperature. Reduce the heat input or increase the heat output.

The amount of water has no or only a little influence on the final operating temperature. The truck itself will work as a big radiator and if there is a huge amount of water in the liquid separator and thereby good contact area between the water and the steel tank, it will give a higher cooling effect. This in combination with low ambient temperature and short time of operation, could mean that the truck can operate without any additional cooling.

In general, the time it takes to heat up the water can be calculated from the formula below.

$$t_{\text{sec}} = \frac{C_p \times m \times \Delta t}{Q}$$

t_{sec} = Time in seconds

C_p = Heat capacity of the media. Water= 4,2

Δt = Temperature difference

m = Mass of the media heating up [Kg]

Q = Heat input in [kW] See specifications, chapter 2.2

Example:

We have a tank with 150 litres of water corresponding to 150 kg. The heat input is 14 kW. How long will it take to heat it up from 20°C to 40°C ?

$$t_{\text{sec}} = \frac{4,2 \times 150 \times 20}{14} = 900 \text{ s} = \underline{15 \text{ min}}$$

The temperature will continue to go up until the steel construction can absorb the heat and transfer it to the surroundings.

With a temperature difference on 20°C it is typical to have a radiator effect in a truck on somewhere between 2 to 10 kW depending on the construction.

The table below shows truck radiator effect at a temperature difference of 20°C.

2 kW	5 kW	10 kW
Small liquid separator mounted external from the truck tank Water content below 50 L	Small liquid separator inside slurry tank. Located with only minor contact to the product Water content 100 L	Normal liquid separator inside slurry tank with good contact to the product Water content 150 L

3.3 Fan cooler

The fan cooler will increase the heat output from the construction and thereby stabilize the temperature at a lower level. However, this cooler will use the air to cool down the water and therefore we will always see that the temperature will be stabilized above the ambient temperature. It's very simple to find the right cooler based on the curves from the cooler manufacturer. Typically you will find the cooler capacity as kW/Δt meaning for example 1.5 kW cooler capacity each °C in temperature difference between the water and the air. Note that the water flow through the cooler will also affect the cooling capacity.

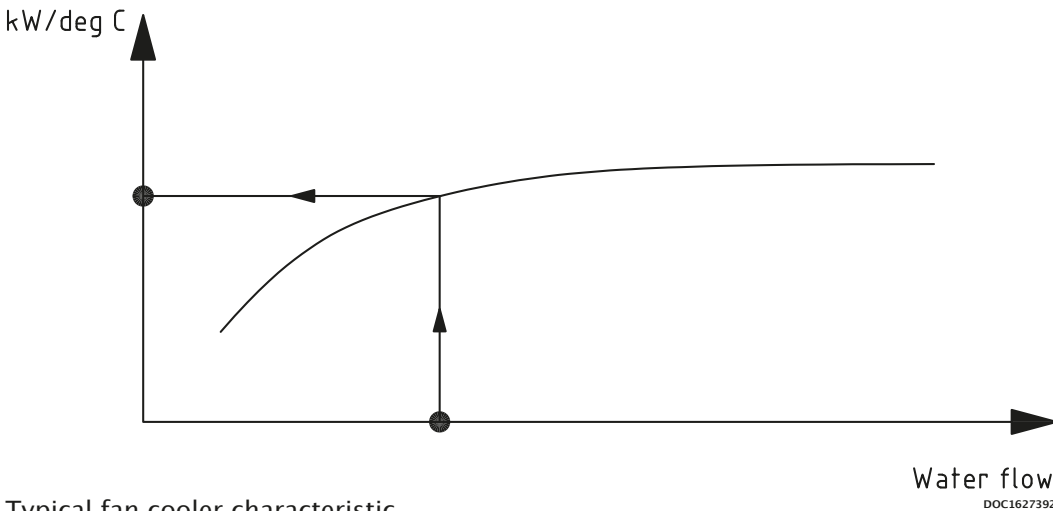

Typical fan cooler characteristic.

Practical calculation example:

The truck is used mostly to work with an operation pressure around 70% vacuum. From the technical data sheet, we find the heat input from the pump to be 11 kW.

The liquid separator is built inside the slurry tank with a good contact to the product and a radiator effect estimated to 10 kW with a temperature difference of 20°C.

The truck will work with ambient temperature up to 28°C during the summer and we will accept a maximum temperature on 40°C.

First, we have to reduce the radiator effect based on a temperature difference of 12°C.

$$Q_{\text{out Truck}} = 10 \times \frac{12}{20} = 6 \text{ kW}$$

The total cooling effect required is thereby:

$$Q_{\text{out Pump}} - Q_{\text{out Truck}} = 11 - 6 = \underline{5 \text{ kW}}$$

Summary

Pump model	Description	Truck Master 600
Heat input from technical specifications	$Q_{in Pump}$	11 kW
Ambient temperature	t_{amb}	28°C
Maximum Working Temperature of the water. This is determined by you. The temperature has influence on the pump performance	t_{op}	40°C
Temperature difference	Δ_t	$t_{op} - t_{amb} = 12^\circ\text{C}$
Truck radiator effect based on 20 °C in temperature difference	$Q_{out Truck 10}$	10 kW
Truck radiator effect based on 12 °C in temperature difference	$Q_{out Truck 6}$	$12/20 * 10 = 6 \text{ kW}$
Total cooling requirement from fan cooler	$Q_{fan cooler}$	$Q_{in Pump} - Q_{out Truck 12} = 11 - 6 = 5 \text{ kW}$

We need to find a fan cooler that can transfer 5 kW with a temperature difference on 12°C. That is 0,42 kW/°C.

If we for example accept a higher temperature, for instance 48°C, we will have full cooling effect from the truck on 10 kW and a cooling requirement on 1 kW. The fan cooler we need to find is thereby on $1/10 = 0,1 \text{ kW/}^\circ\text{C}$ and a big difference to the bigger model calculated above.

3.4 Water consumption

It is possible to design the liquid separator so that almost 100% of the water is separated from the air. However, the air will be heated up and thereby it can content more water. Also, the relative humidity will go up and end near 100%.

So, the air will flow into the pump with maybe 50% relative humidity at a low temperature and be discharged at a higher temperature and humidity. Therefore, there will be an evaporation from the system.

Choose your water temperature

Temp. \ Vacuum	20°C	30°C	40°C	50°C	55°C
50%	6	10	20	35	58
70%	3	6	12	22	36
80%	2	3	5	9	15

Water consumption Liters per hour

3.5 Dome valve system

The liquid ring pump can handle liquid and particles in the inlet but it is of course recommendable to avoid this.

A dome valve or floating valve will ensure that the suction will be closed when the liquid level reaches the top of the tank.

In many situations there will be foam on the liquid surface inside the tank. It can be difficult to avoid that this will be transported into the suction line before the dome valve will close.

Therefore, it will be recommended to make a combination of a filter and dome valve as illustrated below.

The filter will prevent particles lifted by the foam to enter the pump.

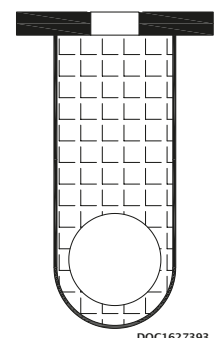

DOC1627393

3.6 System layout (Zone 1/1)



Install an automatic service liquid supply, for example the shown float valve pos 5 - OR provide the liquid separator with an alarm for low level of service liquid pos 17



The maximum working pressure must not exceed specifications, by installing a safety valve.

Systems in this category can be built as illustrated below:

Use an automatic stop valve pos 10, which opens the service liquid supply to the pump when it starts.

Select only 1 safety device (SD), pos. 5 or pos. 17

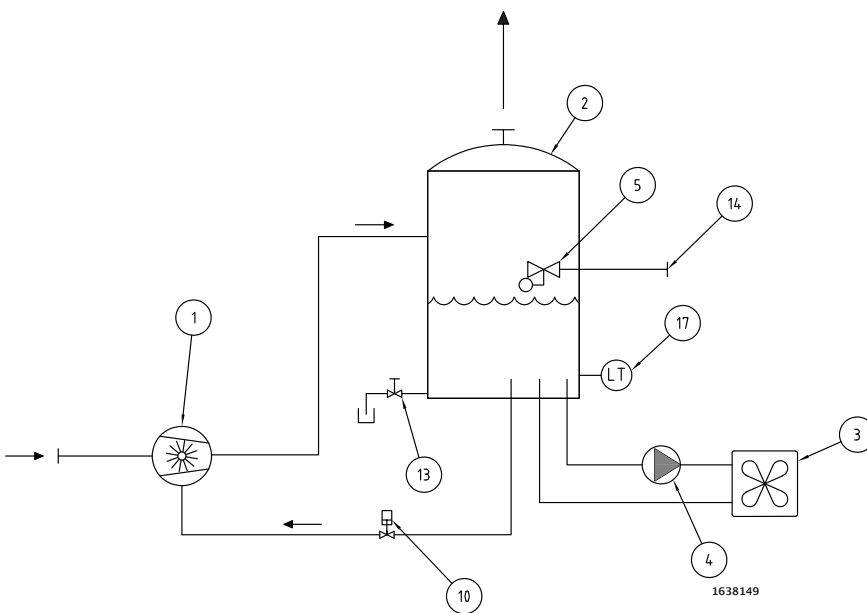

Pos.	Description
1	Vacuum pump
2	Liquid separator
3	Cooler
4	Circulation pump
5	Float valve SD
10	Stop valve
13	Drain valve
14	Service liquid connection
17	Level transmitter SD

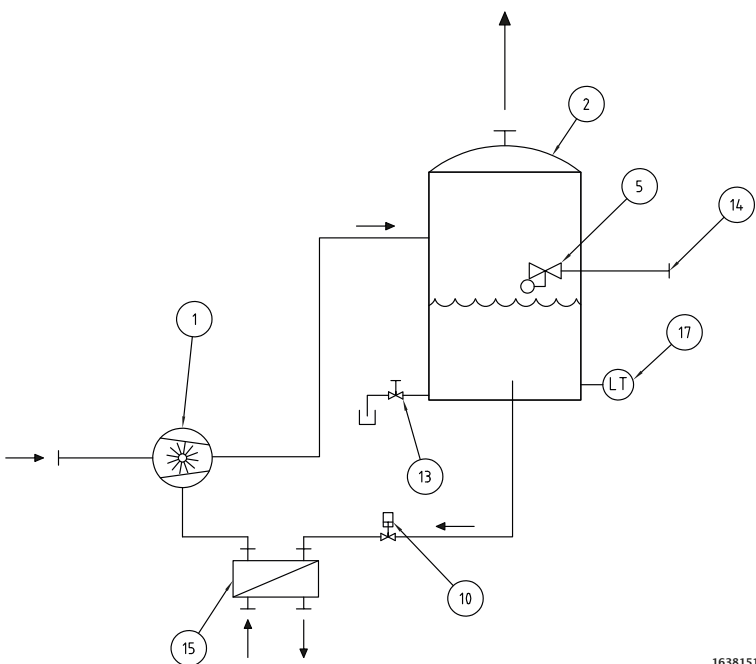

Pos.	Description
1	Vacuum pump
2	Liquid separator
5	Float valve SD
10	Stop valve
13	Drain valve
14	Service liquid connection
15	Plate heat exchanger
17	Level transmitter SD

3.7 Liquid separator



Liquid separator must be mounted in such way that the minimum level of service liquid is minimum 0,5 m above the pump´s shaft



When operating the drain valves, the outlet may contain explosive gases, corresponding to the classification of the pump´s suction side

The liquid separator must be located in immediate proximity to the pump, so that the length of the outlet pipe from the pump is minimised. Due to potential pressure loss, the length may not exceed 2 metres. The level of liquid in the liquid separator is recommended to be kept at 1-1.5 metres above the pump's shaft. This ensures the correct influx pressure and the correct flow of service liquid.

The liquid supply between the liquid separator and pump must be implemented with a permanent pipe connection with a dimension and length specified in specifications.

It may be advantageous to fit the liquid separator with a float valve which automatically supplies liquid and maintains a constant level.

The liquid separator can be fitted with a drain valve at the lowest place in the tank. The valve can be operated when the separator needs to be drained to remove contaminants.

3.8 Cavitation

When the temperature reaches the boiling point of the water, steam bobbles will be created in the liquid ring.

These bobbles cannot exist when they enter the discharge side of the pump and therefore they will collapse. The impact force on the surface of the rotor and flow plate will damage the pump and can lead to a total breakdown. It is a very harmful situation that must be avoided.

It is the combination of the pressure and the temperature that will lead to the cavitation. Therefore, it is recommended to install a cavitation valve, see illustration below that shows a clockwise rotating pump. If counter-clockwise rotating pump, mount in opposite hole.

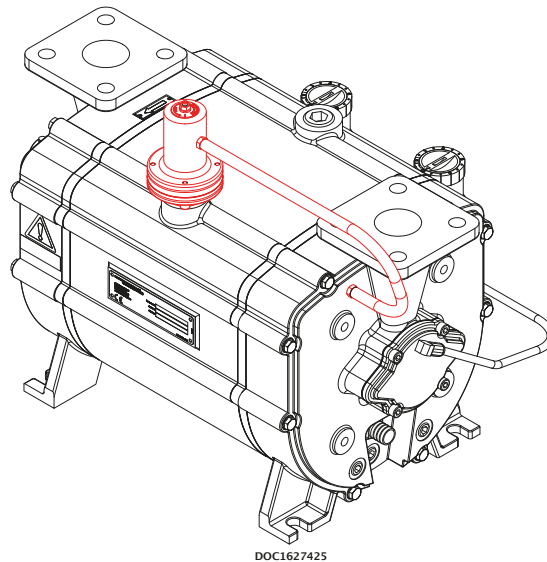

Below you find the boiling point of water as a function of the pressure.

Vacuum	50%	75%	80%	90%
Temperature °C	80	64	59	44
Maximum discharge temperature	70	50	40	30

Note that the temperature of the gas inside the pump will heat up the water and the water surface therefore will become a higher temperature than the measured temperature on the discharge side of the pump. Cavitation will therefore start at a lower temperature and the maximum discharge temperature of the water must be kept lower.

3.9 Service liquid requirement

During operation it is normal that small amount of product will enter the pump, or the gas will react with the water which becomes aggressive.

A normal recommendation is to add glycol to the water in order to protect the liquid ring pump. Glycol will protect the pump and for example the aluminum cooler, but shall only be used in periods with temperature below freezing point.

Due to economical aspect it is more efficient to drain the liquid separator and refill with fresh water instead of protecting with glycol and drain the separator more rarely.

3.10 Pipe system



The exhaust from the liquid separator will have the same zone classification as the pump's suction side

The pipes that are connected to the pump's suction and outlet sides must be at least the same dimension as the pump. The length of the pipe system affects the pump's capacity and should be calculated to account for pressure drop in longer pipe installations.

Depending on the operating pressure, longer pipe lengths may affect the pump's output. For pipe lengths greater than 10 metres, a pressure drop calculation should be made, and the pipe dimensions should be increased so that the pressure loss is held to an acceptable level.

The pipe system should be mounted so that the horizontal pipes have a min. of 1% decline back towards the liquid separator.

Table below can be used for reference values.

Connection	Length < 10 metres	Length 10–50 metres	Length 50–100 metres
Suction side	Min. DN 50	Min. DN 65	Min. DN 100
Outlet side	Min. DN 50	Min. DN 65	Min. DN 100

The outlet from the liquid separator should be led outside of the building because the outlet air is warm and humid.

With respect to the exhaust, measures must be put in place to account for damp air that may form ice in cold surroundings.

3.11 Suction filter

In installations where there is a risk of sucking foreign elements into the pump, a filter must be mounted on the pump's suction side with a maximum mesh size of 2 mm.

4 INSTALLATION AND START-UP

4.1 Securing the pump



Installation requirements must be observed, otherwise there is a risk of damage and of potential explosion

The pump must be installed on a stable foundation, which must be level and stable, so that the pump is not twisted or exposed to a profile distortion.

The pump must be installed with M12 bolts on all four legs, which must be tightened to 60 Nm (A).

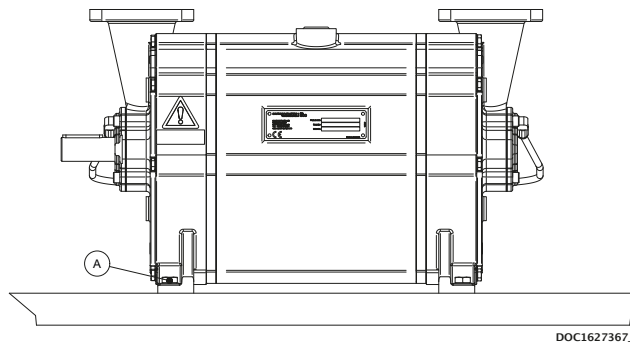

4.2 Connections to the pump



- Check for foreign objects in the pump and physical damage on pump
- Gaskets to be handled with highest degree of caution
- Gasket and sealing surfaces must be cleaned before assembly



External effects on the pump may lead to leakage and, as a result, a potential risk of explosion

Immediate before connecting the pipes, remove protective covers. Connection of the pump's suction and pressure pipe connections must be made with a gasket in between (C).

The M12 bolts must be tightened with 60 Nm (B).

In order to prevent tensions in the pump, the pipe connections (A) must be tensionless while tightening the bolts.

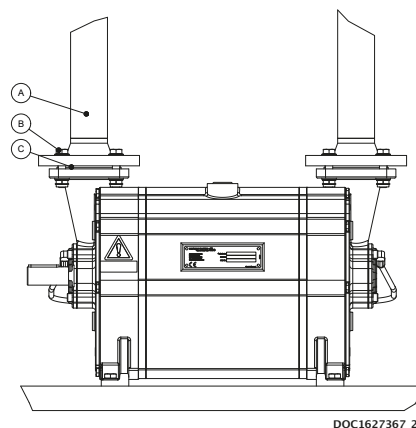

4.3 Connecting the service liquid

The service liquid must be connected to the pump at the hose connection, see illustration below.

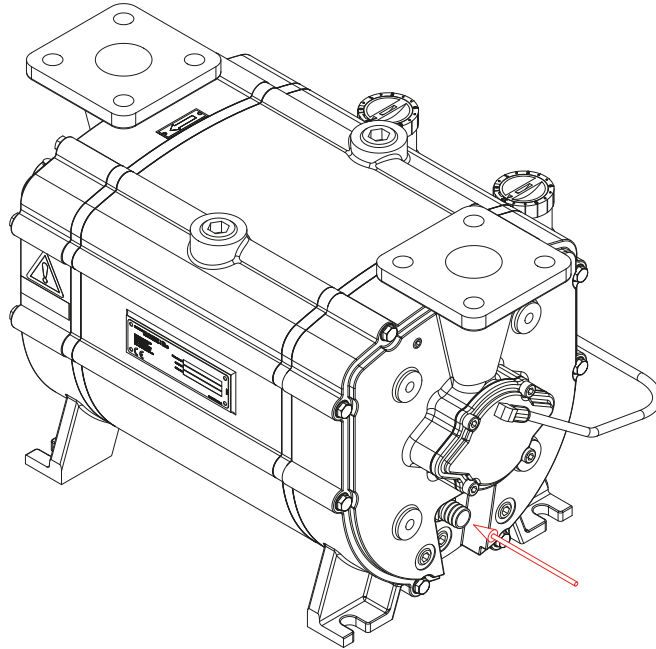

DOC1627365_1

4.4 Transmission

The pump can be connected direct or through belt transmission. For belt transmission, it must be ensured that the permissible radial force is not exceeded. See specifications.

For belt transmission, note the direction of rotation, see illustration below.

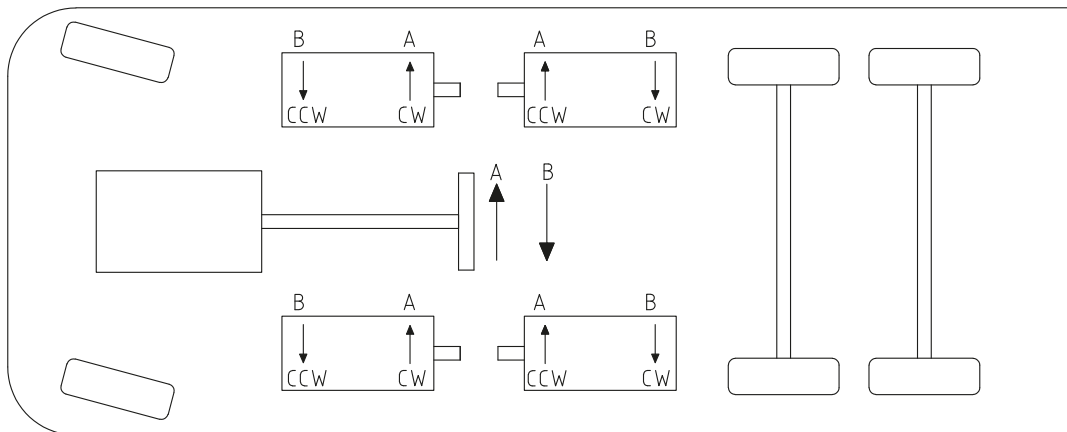

DOC1627416_1

4.5 Earth connection requirements



The pump must be connected to earth to prevent static electricity. Static electricity is a potential source of ignition.

The pump must be protected from the creation of sparks in connection with static electricity, in accordance with the applicable regulations for use in the current categories.

The pump is prepared for earth connection with an M8 bolt.

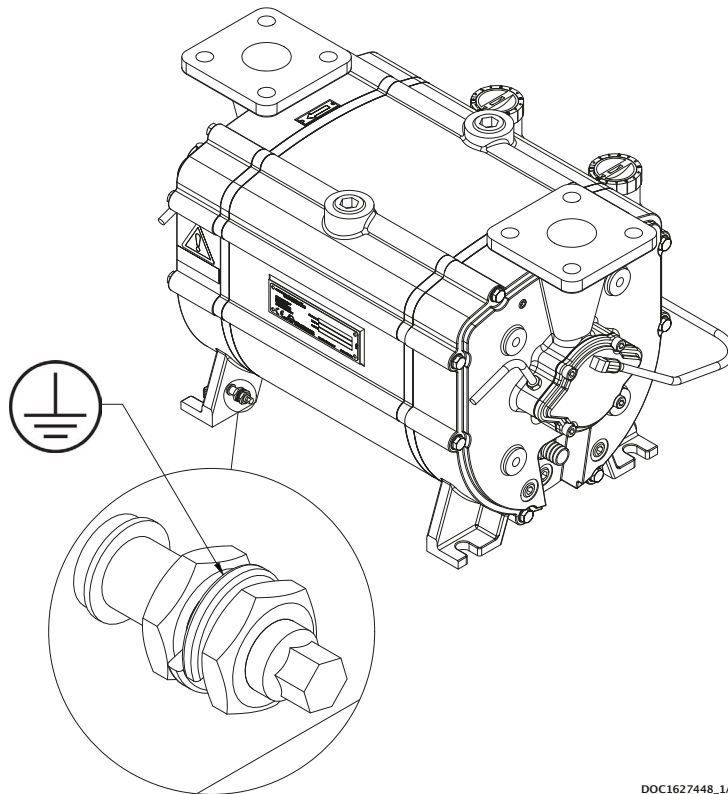

DOC1627448_1A

4.6 Prior to start-up



- Do not start the pump without service liquid, as this will damage the mechanical shaft seals
- Do not start the pump if it is completely filled with service liquid
- Do not start the pump before the grease cartridges have been activated, as this can damage the pump (if equipped)
- Stop the pump immediately if the rotational direction does not correspond to the directional arrow
- A failure to follow the above guidelines may result in damage to the pump

Activating the grease cartridges

Turn the handle in NDE clockwise to position 12.
Turn the handle in DE clockwise to position 12.
The pump has been lubricated from factory and is ready to start.



DOC3707

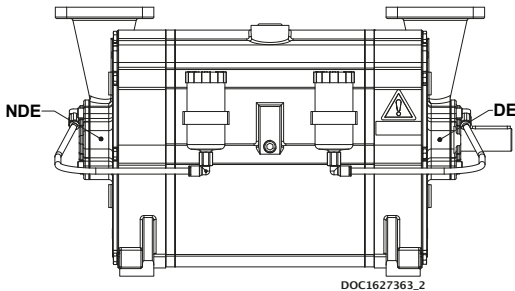

DOC1627363_2

4.7 Direction of rotation

Check the direction of rotation by briefly starting the pump.

The direction of rotation of the rotor must correspond to the direction arrow!

Below left, a right-side pump is shown which has a clockwise direction of rotation (CW)

Below right, a left-side pump is shown which has a counter-clockwise direction of rotation (CCW)

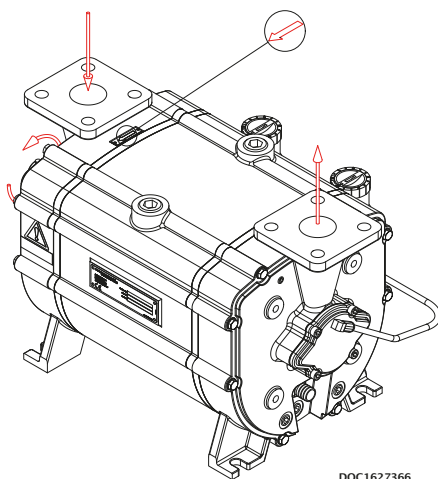

DOC1627366

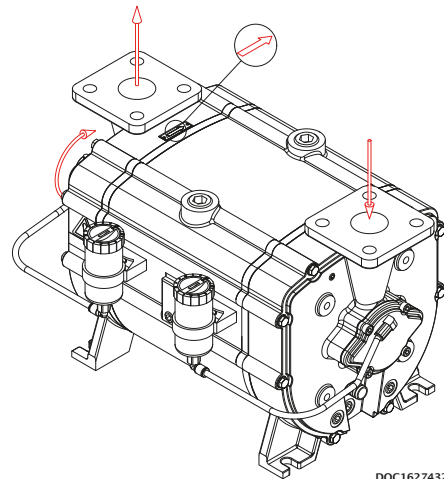

DOC1627432

5 SERVICE, OPERATION, MAINTENANCE AND INSPECTION INTERVALS



A failure to observe the inspection intervals described in table below may result in damage to the pump and a potential risk of explosion

Section	Operation	Interval
5.1	Inspection of bearings	Weekly
5.2	Visually inspect for leakage	Weekly
5.3	Drain liquid separator to remove contaminants	Weekly
5.4	Check grease cartridges (if equipped)	Weekly
5.5	Lubrication of bearings	Per 500 duty hours
5.6	Inspection of ATEX safety device	Monthly
5.7	Inspection and cleaning (if necessary) of service liquid's supply pipe	Monthly
5.8	Calibration of ATEX safety device	Annually
5.9	Overhaul of pump	10,000 duty hours
5.10	Inspection and cleaning of internal channels	Monthly
5.11	Winterization	When below 0°C
6	Troubleshooting	As required

5.1 Inspection of bearings

The bearings of pump must be inspected once a day.

Be alert of unfamiliar sounds from bearing.

The measurements are preformed after MIN. 30 min. of operation.

If operation time is less than 30 min., perform the measurements immediately after longest period of operation.

Temperature of bearings must not exceed the permitted temperature described in system layout.

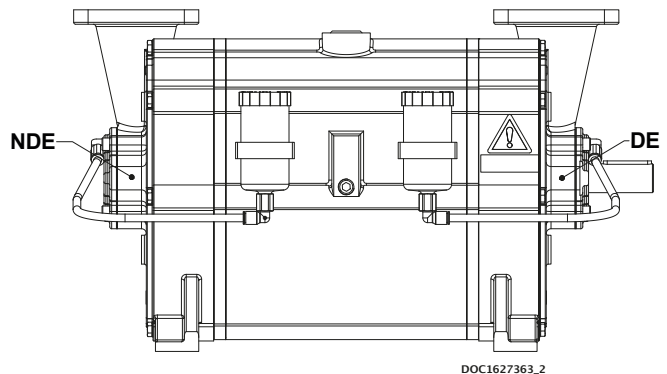

Pump	TM 600
Drive end (DE)	72°C
Non drive end (NDE)	72°C

5.2 Inspecting for leakage

The pump and pipe system around the pump must be inspected for leakage once a week. The inspection must be performed when the pump is both operating and idle. Any leaks must be repaired before operation may continue.

5.3 Draining the liquid separator

While the pump is stopped, the liquid separator must be drained to remove contaminants.

5.4 Check grease cartridges (Category 2 pumps with grease cartridges)



To prevent electrostatic discharge in hazardous areas, only wet cleaning is permitted. Appropriate measures must be taken to prevent electric discharge.

If the pump is equipped with an automatic lubrication feature, it must be inspected and replaced as needed.

When the pump is commissioned for the first time, the cartridges must be activated by turning the arrow in the clockwise direction.

The cartridge is set to 12, which corresponds to an emptying time of 12 months. The cartridge must be replaced when empty.



It is only allowed to use automatic lubricator of type **LAGD 125/WA2**.

5.5 Lubrication of bearings (Category 2 pumps without grease cartridges)



Over-lubrication of bearings may result in bearing damage! Do NOT exceed the amount of grease specified below!

The bearings must be lubricated with grease of type **SKF LGWA2**, per 500 duty hours. It is recommended to lubricate the bearings while pump is running.

Lubrication interval per 500 duty hours	
Drive end (DE)	3 g
Non drive end (NDE)	3 g

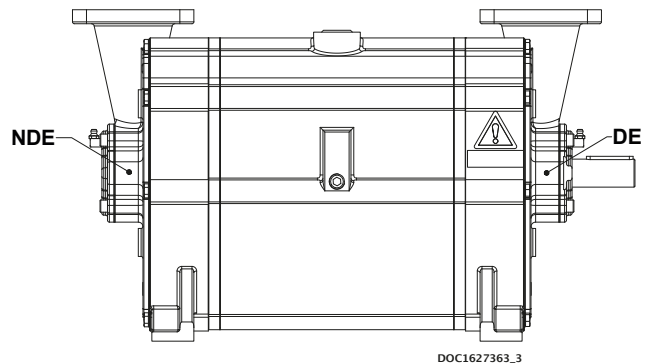

5.6 Inspection of ATEX safety device



ATEX safety device must be inspected in accordance with table to ensure proper functionality. A failure to perform the required inspections will result in the discontinuation of the pump's approval

Safety devices to be inspected in accordance with applicable regulations.
The components that make up the safety device can be found in the system layout.
Float valve must be cleaned.

5.7 Inspection and cleaning of service liquid's supply pipe

The pipe connection between the liquid separator and pump must be inspected at least once a month, and any contaminants must be removed.

5.8 Calibration of ATEX safety device

Level transmitter (if equipped) must be calibrated once a year in accordance with the applicable requirements.
The pump may not be started before the instruments have been re-installed.

5.9 Overhaul of pump

The pump must be serviced after 10,000 duty hours. This is done by sending the pump to Samson Pumps, or approved and certified partner, upon agreement. The pump must be cleaned before shipment.

Repairs carried out on ATEX pumps may only be performed by Samson Pumps, or approved and certified partner. If this requirement is not observed, and the pump's seal is broken, the pump's declaration of conformity is not valid and Samson Pumps is no longer responsible for any resulting consequences.

5.10 Inspection and cleaning of internal channels

The pump is designed with internal water channels for lubrication of the mechanical shaft seals. Remove the plug as illustrated below and clean the channel using a $\varnothing 5$ mm 150 mm long screw driver or similar.

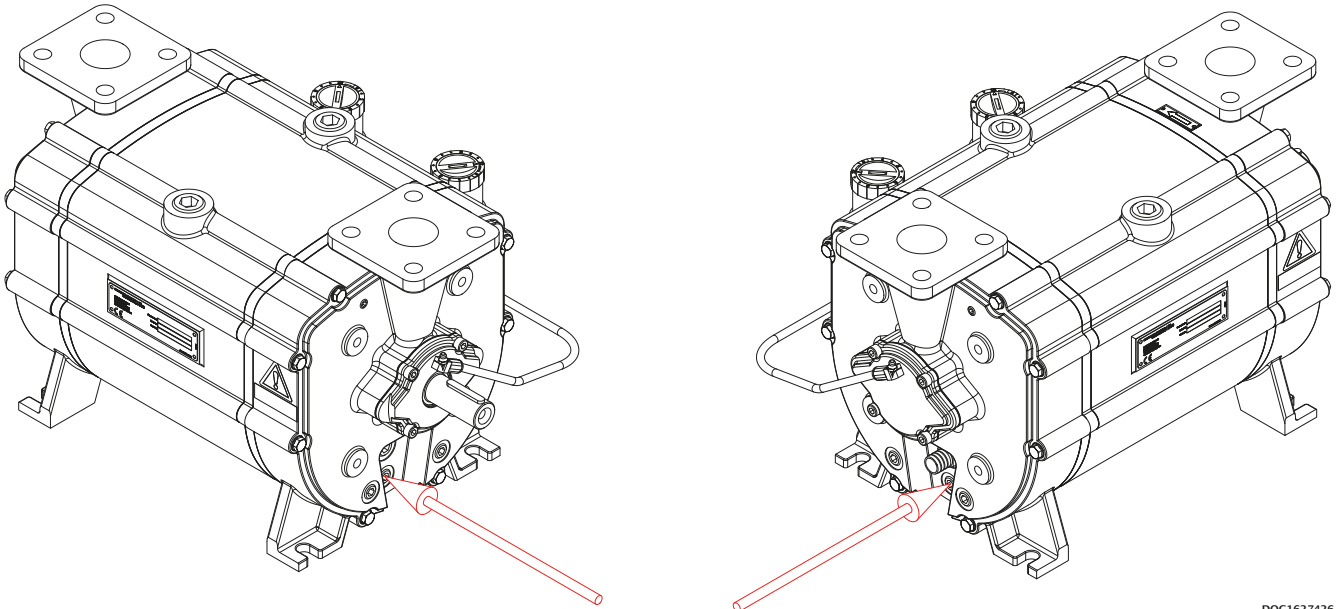

DOC1627426

5.11 Winterization

If the pump needs to be used at a temperature below freezing point of the service liquid, it is necessary to protect the liquid from freezing by adding anti freeze liquid.

6 TROUBLESHOOTING

Problem	Cause	Effect	Corrective measure
The pump is unable to create a vacuum	<ul style="list-style-type: none"> • Service liquid valve is closed • The pump is not receiving enough service liquid • The temperature of the service liquid is too high 	<ul style="list-style-type: none"> • Reduced output • The pump can become damaged during cavitation 	<ul style="list-style-type: none"> • Check service liquid valve • Check the liquid supply • Stop the pump and wait until the temperature has dropped to a sufficient level, or lower the temperature of the service liquid inlet
The start-up power is too high	<ul style="list-style-type: none"> • Too much service liquid in the pump prior to start-up 	<ul style="list-style-type: none"> • Noise at start-up and possible overload of the power supply 	<ul style="list-style-type: none"> • Check the stop valves in the liquid supply for leakage
Noise during operation	<ul style="list-style-type: none"> • Cavitation 	<ul style="list-style-type: none"> • Severe damage to the pump and potential risk of breakdown 	<ul style="list-style-type: none"> • Increase the suction pressure or lower the temperature of the service liquid
Leakage from the bearing housing's drain holes	<ul style="list-style-type: none"> • Damaged shaft seal 	<ul style="list-style-type: none"> • Bearings may become damaged • Potential risk of explosive gas leak 	<ul style="list-style-type: none"> • Stop the pump and contact the manufacturer

7 SPARE PARTS AND TOOLS

7.1 Marking and identification

The pump is equipped with an identification plate as shown below.

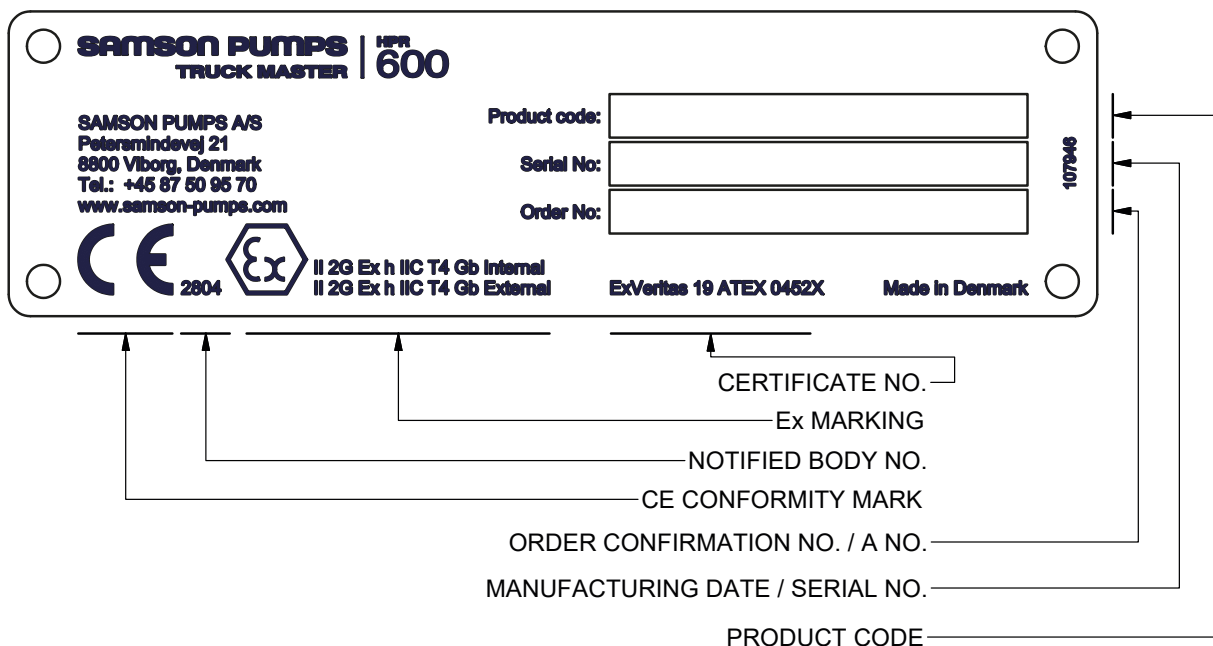

Configuration example:

TM 600 R 0 S S B 1 0 T X1

- Type: ←
- Model: ←
- Rotation: ←
- Rotor type: ←
- Pump housing: ←
- Shell: ←
- Flow plates: ←
- Generation of pump: ←
- Gaskets: ←
- Colour: ←
- Documentation: ←

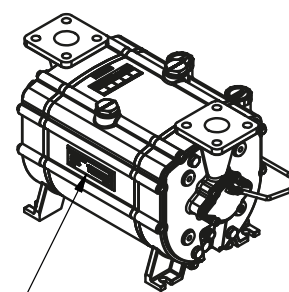

Location of ID plate

DOC107946C

7.2 How to order

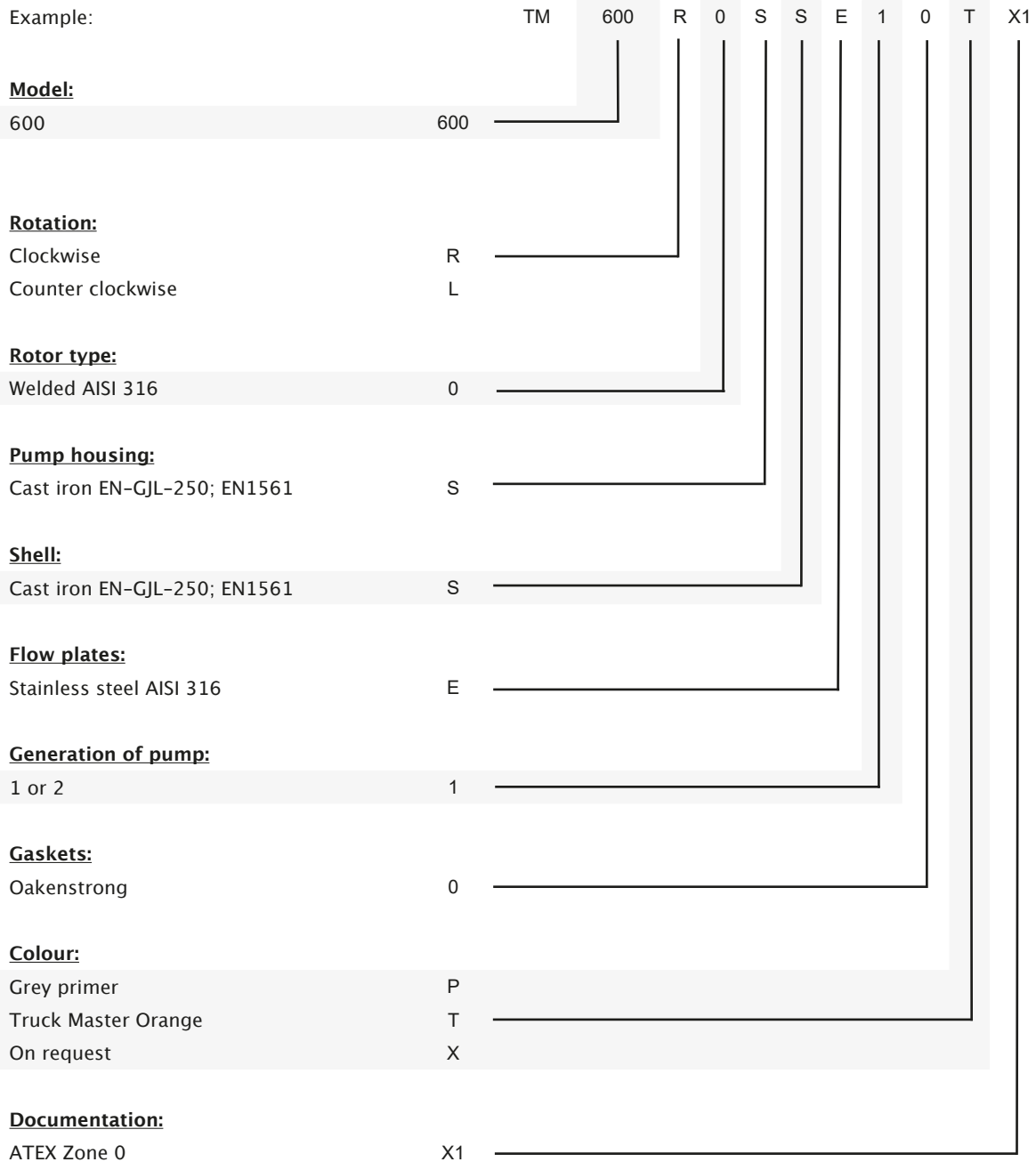

7.3 Spare parts

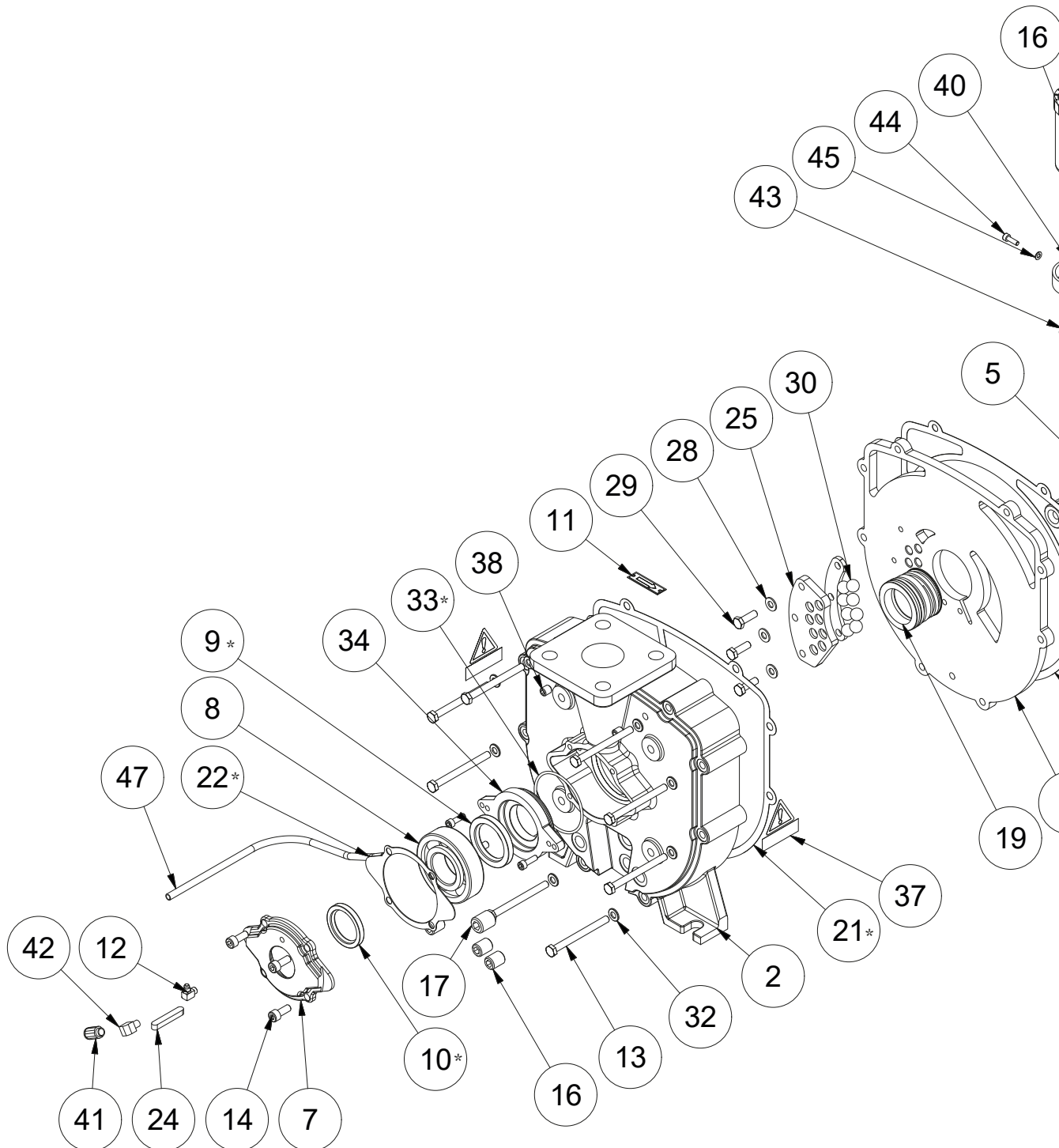

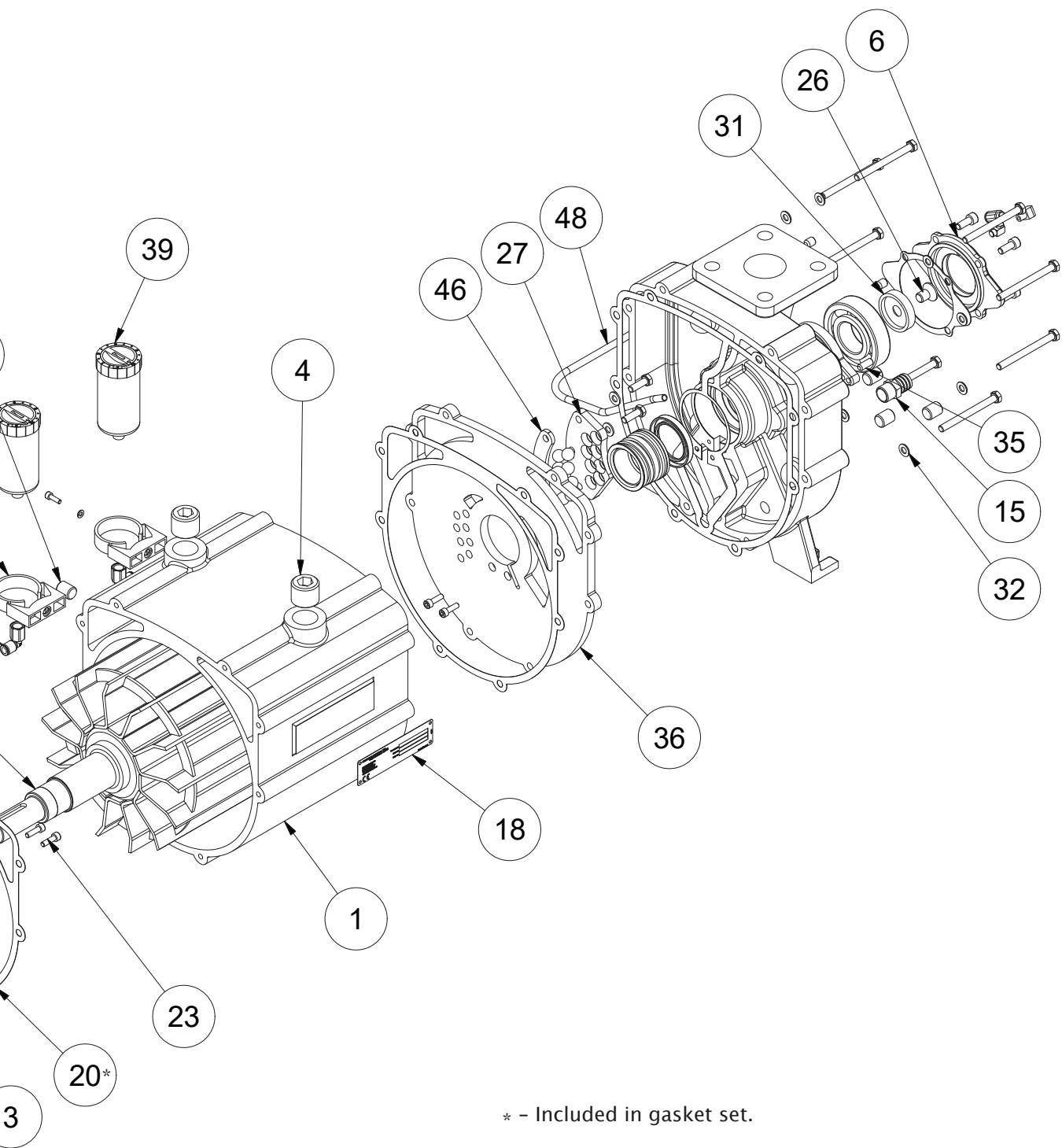

* - Included in gasket set.

DOC1623099

Pos.	Part number	Description	Qty.	Material
1	1623013	Shell	1	Cast iron EN-GJL-250, EN 1561
2	1623057	Pump housing	2	Cast iron EN-GJL-250, EN 1561
3	1623004	Flow plate	1	SS W.Nr. 1.4404
4	910300182	Plug	2	Steel DIN 906
5*	1623094	Rotor R	1	SS EN 1.4418 / AISI 316L
	1623097	Rotor L	1	SS EN 1.4418 / AISI 316L
6	1623061	Bearing cover NDE	1	Cast iron EN-GJL-250, EN 1561
7	1623062	Bearing cover DE	1	Cast iron EN-GJL-250, EN 1561
8	930000081	Ball bearing	2	Chrome steel W.Nr. 1.3505
9	1601003	Gasket set Truck Master 600	1	-
10	1601003	Gasket set Truck Master 600	1	-
11	-	Direction arrow	1	Aluminum
12	915000197	Grease nipple	2	Steel VFZ
13	910000020	Bolt	16	Steel DIN 931 FZB
14	910300024	Allen screw	8	Steel DIN 912 FZB
15	925000246	Hose nipple	1	Brass
16	910300188	Plug	7	Steel DIN 906
17	910300184	Plug	1	Steel DIN 906
18	-	Identification plate	1	SS AISI 316
19	922000042	Mechanical shaft seal	2	NBR / AISI 316 / Carbon
20	1601003	Gasket set Truck Master 600	1	-
21	1601003	Gasket set Truck Master 600	1	-
22	1601003	Gasket set Truck Master 600	1	-
23	910300447	Allen screw	6	SS AISI 316
24	915000210	Parallel key	1	Steel DIN 6885A
25	1623025	Ball guide	1	Plastic PEHD 1000
26	910300459	Allen screw	1	Steel DIN 7991 FZB
27	1623026	Ball guide	1	Plastic PEHD 1000
28	910100004	Washer	6	SS AISI 316 DIN D125A
29	910000487	Bolt	6	SS AISI 316 DIN 933
30	962000046	Valve Ball	16	Plastic PPH100NA-20M
31	1623063	Washer	1	SS AISI 316
32	910100007	Washer	16	Steel DIN 125B FZB
33	1601003	Gasket set Truck Master 600	1	-
34	1623065	Adjustment plate	2	Cast steel W.Nr. 1.0446
35	910300125	Socket set screw	2	Steel DIN 916

* -See section 7.1 for identification of pump.

** -Optional. Not equipped as standard.

Pos.	Part number	Description	Qty.	Material
36	1623015	Flow plate	1	SS W.Nr. 1.4404
37	1624020	Sticker Warning!	2	Plastic foil FasCal 400
38	910300281	Plug	4	Steel DIN 906
39**	915000225	Automatic lubricator LAGD 125/WA2	2	Plastic PA6 / grease
40**	915000232	Clamp for automatic lubricator	2	Plastic PA6
41**	944600239	Push-in nipple	2	Brass
42**	944600173	Elbow	2	Steel S235
43**	944600240	Elbow	2	Plastic PBT / Brass
44**	910300221	Allen screw	2	Steel DIN 912 FZB
45**	910100002	Washer	2	Steel D125B
46	1623027	Spacer for ball guide	2	SS W.Nr. 1.4401
47**	915000217	Plastic pipe	0,3 m	Plastic PA6
48**	915000217	Plastic pipe	0,3 m	Plastic PA6

* -See section 7.1 for identification of pump.

**-Optional. Not equipped as standard.

7.4 Gasket set



DOC11592

Pos.	Part number	Description	Qty.	Material
9	922200051	Radial shaft seal 45x65x8	2	Rubber NBR DIN 3760A
10	922200036	Radial shaft seal 40x55x7	1	Rubber NBR DIN 3760A
20	1623022	Gasket for shell / flow plate 0,4 mm	2	Paper Oakenstrong
	1623055	Gasket for shell / flow plate 0,8 mm	2	Paper Oakenstrong
21	1623023	Gasket for pump housing / flow plate 0,4 mm	2	Paper Oakenstrong
22	1623066	Gasket for bearing cover 1 mm	2	Rubber NBR
	1623024	Gasket for bearing cover 0,4 mm (<2012)	2	Paper Oakenstrong
33	922100359	O-ring Ø74,50x3,00	2	Rubber NBR

See spare parts drawing (DOC1623099) for positions.

7.5 Special tool set

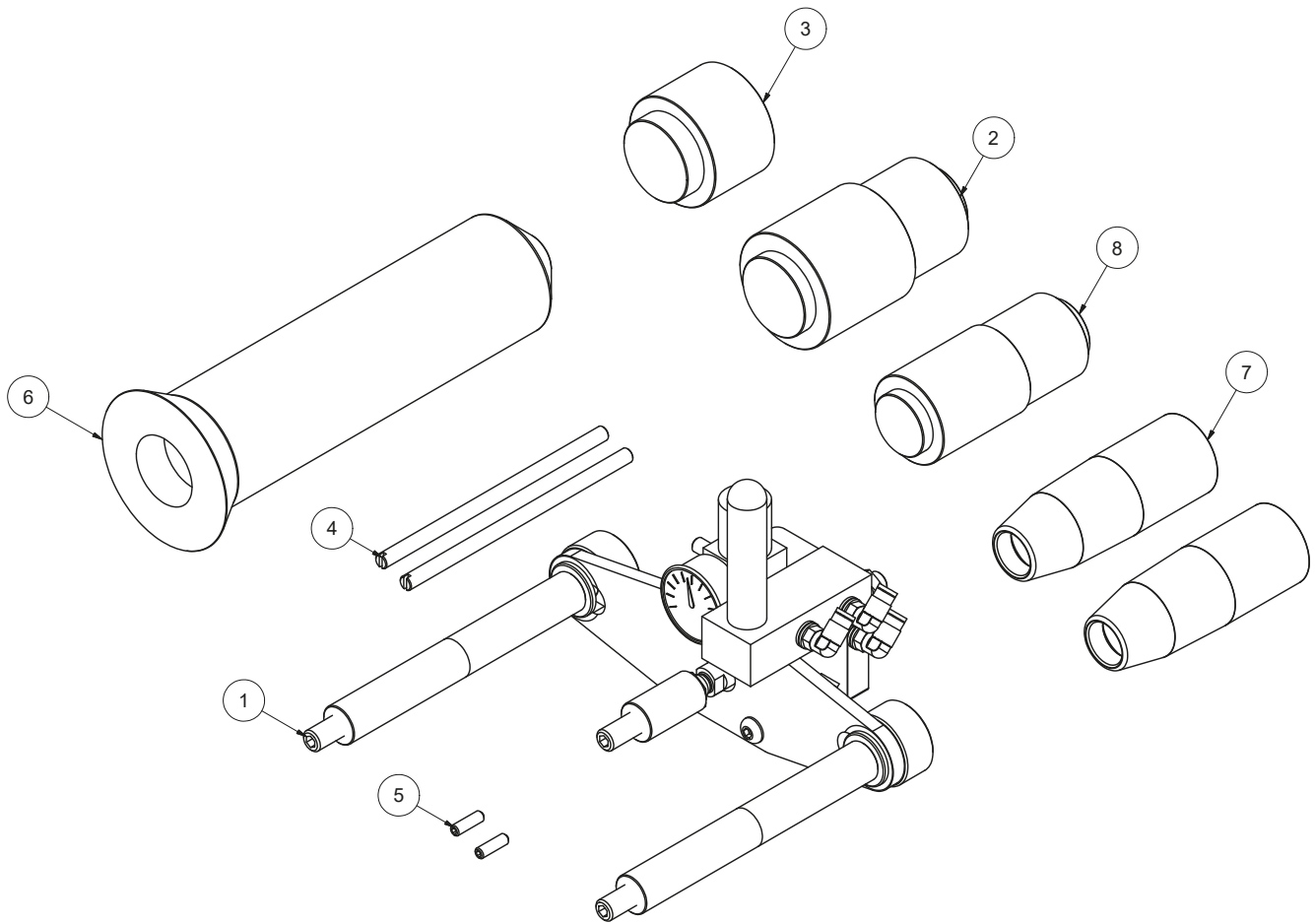

DOC1629268_1

Pos.	Part number	Description	Qty.	Material
1	1629136	Bearing tool	1	Steel / Brass / Al / PA
2	1629196	Mandrel radial shaft seal Ø30 + Ø45	1	Plastic POM
3	1629197	Mandrel mechanical shaft ring	1	Plastic POM
4	1629194	Guide pin M8	2	SS AISI 316
5	910300428	Socket set screw	2	SS DIN 916
6	1629193	Bearing mounting tool	1	Plastic / Aluminum
7	1629079	Assembly bush	2	Plastic POM
8	1629195	Mandrel radial shaft seal Ø35	1	Plastic POM

Notes:

Notes:

SAMSON PUMPS

Samson Pumps is the only company in the world to specialise exclusively in liquid ring vacuum pumps. Samson pumps are made in Denmark and used around the globe. We offer worldwide delivery, and we export to more than 80 countries around the world.

For over 40 years, our name has been synonymous with the strongest pumps for vacuum trucks and tankers. We constantly adapt our products to meet the changing needs of our customers. Today, it is not enough to simply produce a pump. Products must be refined so the customer can concentrate on what they do best. We therefore offer a wide range of standardised components that allow our customers to build vacuum systems without the need for specialist in-house expertise.

Strength and durability are our hallmarks! We have often heard from customers that our pumps are working in many years, and in most cases without the need for maintenance or repair. This emboldens us to say that we have the strongest program of pumps on the market.