

## INSTRUCTION MANUAL

LIQUID RING PUMP

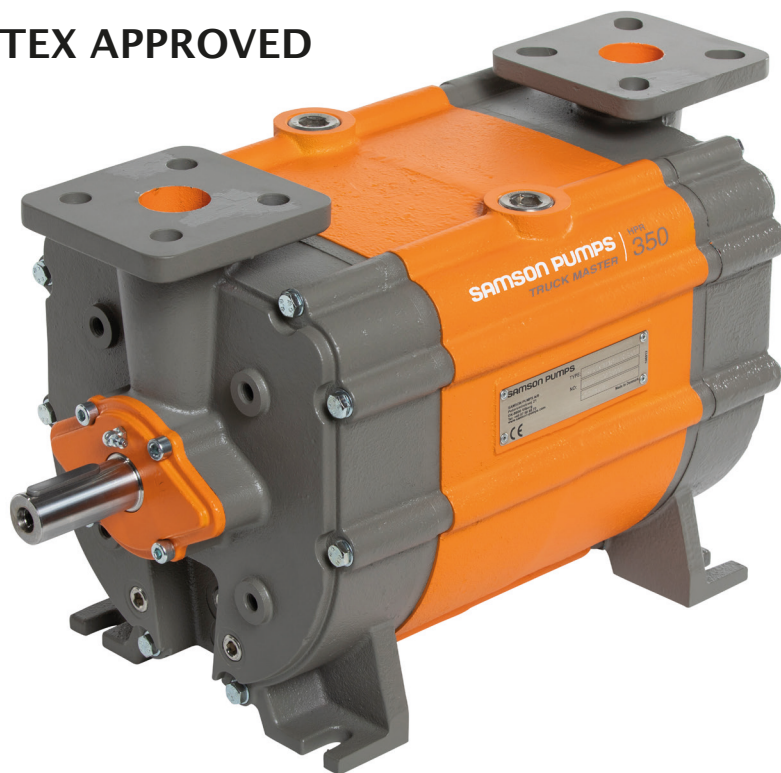

ATEX APPROVED



Zone 0 Internal / Zone 1 External

# TRUCK MASTER® 350

INSTRUCTION MANUAL FOR SAMSON LIQUID RING PUMP  
TRUCK MASTER 350

- 
- Technical data
  - Design of a system
  - System layout
  - Installation and start-up
  - Service
  - Troubleshooting

---

# CONTENTS

<b>1</b>	<b>Introduction .....</b>	<b>4</b>
1.1	Declaration of conformity.....	4
1.2	Explanation of warning symbols.....	5
1.3	Disposal.....	5
1.4	ATEX Directive 2014/34/EU .....	6
1.5	Field of application.....	7
<b>2</b>	<b>Technical data.....</b>	<b>8</b>
2.1	Dimensions.....	8
2.2	Specifications.....	9
2.3	Power consumption and output.....	10
2.3.1	Vacuum .....	10
2.3.2	Pressure.....	10
2.3.3	Correction factor - Temperature .....	11
2.3.4	Correction factor - Wet and dry gas.....	11
2.4	Handling and transport .....	12
2.5	Pump storage and draining procedure.....	13
<b>3</b>	<b>Design of a system .....</b>	<b>14</b>
3.1	Function and design of a liquid separator.....	15
3.2	Air cooling with fan cooler .....	16
3.3	Fan cooler .....	17
3.4	Water consumption .....	19
3.5	Dome valve system .....	19
3.6	System layout (Zone 0/1) .....	20
3.6.1	Safety Integrity Level (SIL) according IEC 61508.....	22
3.7	Liquid separator.....	22
3.8	Cavitation .....	23
3.9	Service liquid requirement.....	23
3.10	Pipe system.....	24
3.11	Suction filter .....	24

---

<b>4</b>	<b>Installation and start-up.....</b>	<b>25</b>
4.1	Securing the pump.....	25
4.2	Connections to the pump.....	25
4.3	Connecting the service liquid.....	26
4.4	Transmission.....	26
4.5	Earth connection requirements.....	27
4.6	Prior to start-up.....	28
4.6	Direction of rotation.....	28
<b>5</b>	<b>Service, operation, maintenance and inspection intervals.....</b>	<b>29</b>
5.1	Inspection of bearings.....	29
5.2	Inspecting for leakage.....	29
5.3	Draining the liquid separator.....	29
5.4	Check grease cartridges.....	30
5.5	Inspection of ATEX safety device.....	30
5.6	Inspection and cleaning of service liquid's supply pipe.....	30
5.7	Calibration of ATEX safety device.....	30
5.8	Overhaul of pump.....	30
5.9	Winterization.....	30
<b>6</b>	<b>Troubleshooting.....</b>	<b>31</b>
<b>7</b>	<b>Spare parts and tools.....</b>	<b>32</b>
7.1	Marking and identification.....	32
7.2	How to order.....	33
7.3	Spare parts.....	34
7.4	Gasket set.....	38
7.5	Special tool set.....	39

# 1 INTRODUCTION

## 1.1 Declaration of conformity

**SAMSON PUMPS**

### Declaration of Conformity

Annex IIA

#### Samson Pumps A/S

Petersmindevej 21  
DK-8800 Viborg

Hereby declares that the following products:

#### Liquid ring pumps

**TM3400, TM2500, TM1700, TM1600, TM600, TM350, SLP2100, SLP2700, SLP3100**

Conforms to the following directives:

**Machinery Directive 2006/42/EC**  
**ATEX Directive 2014/34/EU**

Explosion protection as follows on nameplate:

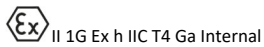
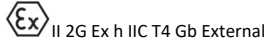
I hereby declare, that the machine are in conformity with the following harmonized standards:

DS/EN ISO 12100:2011	Safety of machinery - General principles for design - Risk assessment and risk reduction
DS/EN 1012-2 + A1:2009	Compressors and Pumps - Safety requirements - Part 2: Vacuum pumps
DS/EN 1127-1:2011	Explosive atmospheres - Explosion prevention and protection - part 1: Basic concepts and methodology
DS/EN ISO 80079-36:2016	Explosive atmospheres - Part 36: Non-electrical equipment for explosive atmospheres - Basic method and requirements
DS/EN ISO 80079-37:2016	Explosive atmospheres - Part 37: Non-electrical equipment for explosive atmospheres - Non-electrical type of protection constructional safety "c", control of ignition sources "b", liquid immersion "k"

The standard above only applies to the extent that it is relevant for the purpose of the pump. The product must not be used before the complete system, which it must be incorporated in, has been conformity assessed and found to comply with all relevant health and safety requirements of 2006/42/EC and other relevant directives. The product must be included in the overall risk assessment.

EU TYPE-Examination Certificate Number **ExVeritas 19 ATEX 0452X**  
Certification body Identification Number **2804**

Viborg, 06.02.2020

  
Jan S. Christiansen – Manager, Technical dept.

DOC4046C

E-Mail | info@samson-pumps.com | Samson Pumps A/S | Petersmindevej 21  
Web | www.samson-pumps.com | Phone | +45 87 50 95 70 | DK-8800 Viborg

---

## 1.2 Explanation of warning symbols

Important technical and safety instructions are shown by symbols. If the instructions are not performed correctly, it can lead to personnel injuries or incorrect function of the pump.



To be used with all safety instructions that must be followed. A failure to follow the instructions may result in injuries and/or incorrect machine operation



This symbol stands for safety instructions which – if they are not observed – may lead to a risk of explosion. You must therefore always follow these instructions.

## 1.3 Disposal

Samson's liquid ring pump is manufactured so that most of the device can be reused/recycled.

Samson Pumps offer users of the company's pumps the option of returning used pumps to be restored or scrapped.

Alternatively, the pump must be taken apart and sorted into its separate components, by the customer (see section 7 for the pump's material).

These components must be disposed of in accordance with national regulations.

---

## 1.4 ATEX Directive 2014/34/EU

The pump may be incorporated into a larger system, if the internal atmosphere has an area classification of:  
Zone 0 (for ATEX category 1 pumps)

These systems will be certified in accordance with the ATEX Directive 2014/34/EU

For the certification to be valid, the pump must be installed as described in this manual.



II 1G Ex h IIC T4 Ga Internal

II 2G Ex h IIC T4 Gb External

ExVeritas 19 ATEX 0452X

Explanation of symbols and characters used in ATEX marking:



The European Commission's mark for Ex products

- II     Equipment group II (non-mining)
- 1     Equipment category
- G     Type of explosive atmosphere (G = Gas)
- Ex    Indication of equipment for use in potentially explosive atmospheres
- h     Explosion protection
- IIC    Gas group (explosion group)
- T4    Temperature class (T4 = 135°C)
- Ga    Equipment protection level

ExVeritas 19 ATEX 0452X is the certificate number.

Special Conditions for Safe Use:

For pumps classified Ga (Zone 0), temperature monitoring is required on the bearings to initiate a shutdown of the equipment in case bearings exceed the temperature, listed under Section "System layout (Zone 0/1) in the Instruction Manual. The temperature sensors must be connected to a monitoring and shutdown system which is sufficiently reliable and compliant with the requirements for ATEX safety related devices and systems as defined in Annex II, clause 1.5.1 of Directive 2014/34/EU (i.e. b1 (SIL1) as defined by EN ISO 80079-37 cl. 6.5).

Refer to manufacturer's Instruction Manual for correct installation and maintenance.

---

## 1.5 Field of application



Inlet of foreign objects, including condensing gases can damage the pump



The pump is designed exclusively to pump gases, including atmospheric air



**WARNING!**  
Do not operate the pump so that cavitation can occur! For further information see instruction manual for the Samson Pumps vacuum limiter

It must be ensured that the inlet gas cannot react with the service liquid and create aggressive bonds that break down the pump's components.

For other operating data, see specifications.

- The pump may only be used with media that are not aggressive to the pump's materials. See section 7.3 for components and appertaining materials.
- When using ATEX-approved pumps, refer to the marking on the pump and the areas of application specified in the ATEX Directive.

# 2 TECHNICAL DATA

## 2.1 Dimensions

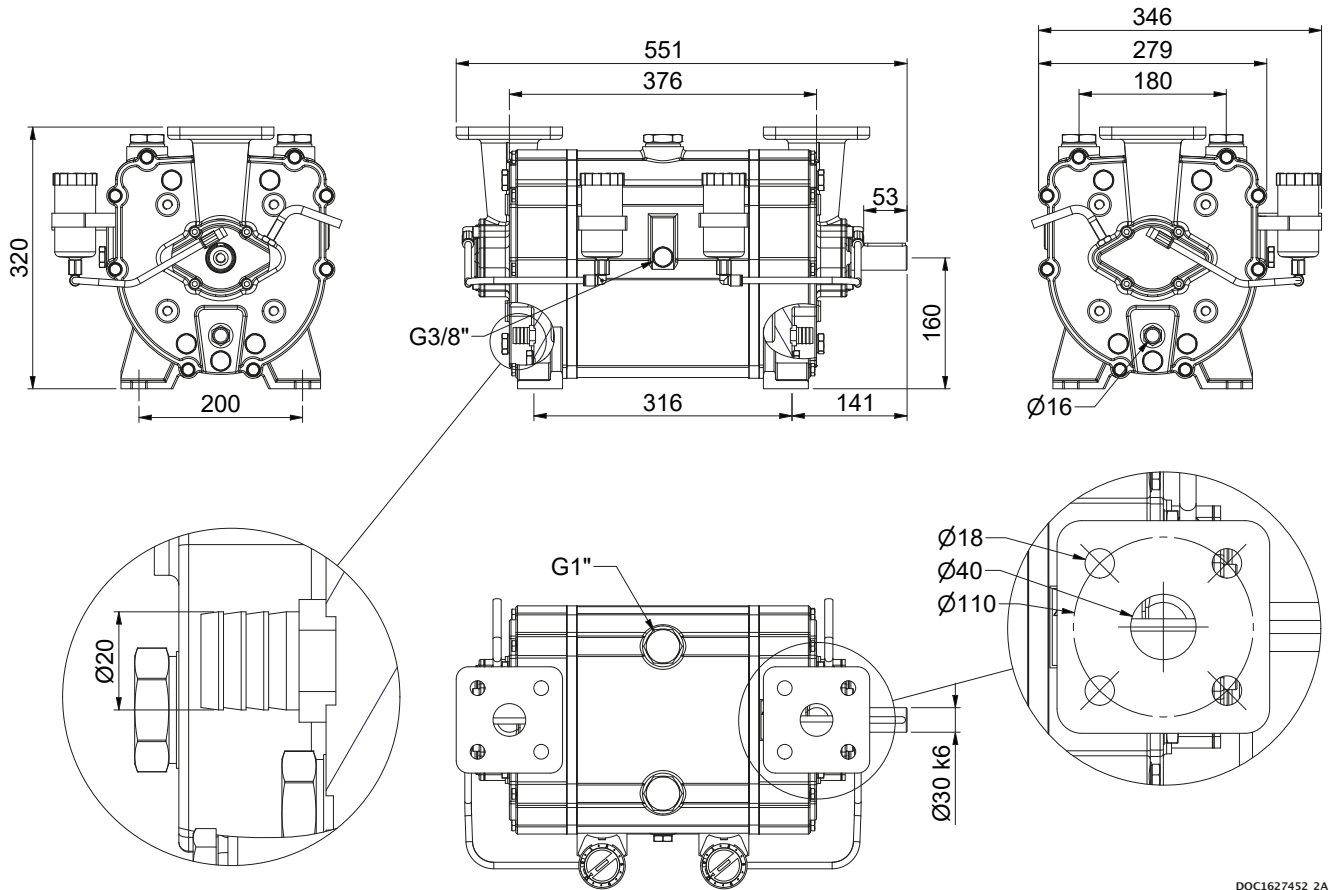

DOC1627452\_2A



## 2.2 Specifications



A failure to meet these specifications may result in damage to the pump and a potential risk of explosion

Description		Minimum	Maximum
Ambient temperature, operation	Below 0°C – see chapter 5.9	-20°C	55°C
Ambient temperature, storage		-20°C	55°C
Humidity		-	100%
Intake temperature, suction side		-	60°C
Intake temperature, service liquid		-	60°C
Service liquid pipe connection, dimension		½"	-
Service liquid pipe connection, length		-	6 m
For all connections, it is recommended to use the pump's existing connection size as minimum size.			
Noise level		-	70 dB(A)
Water volume		-	7 L
Maximum radial load on drive shaft		-	1400 N
Heat input for cooler calculation	1200 rpm	4 kW	-
	1500 rpm	5 kW	-
	1650 rpm	6 kW	-
	1800 rpm	7 kW	-
Revolutions		1200 rpm	1800 rpm
Pressure		150 mbar abs.	1 bar(g)
Lubricating grease	Type of grease	SKF LGWA2	
	Automatic lubrication*	SKF LAGD 125/WA2	
Weight		84 kg	

It is required to install liquid separator to ensure the pump is supplied as much water as needed. See System layout Zone 0/1.

\* -Automatic lubrication:           Zone 0/1 – Requirement.

## 2.3 Power consumption and output

### 2.3.1 Vacuum

	Vacuum	[%]	80	70	60	50	40	30	20
<b>1200 [rpm]</b>	Flow <sub>Wet</sub>	[m <sup>3</sup> /h]	106	177	192	190	199	202	212
	Flow <sub>Dry</sub>	[m <sup>3</sup> /h]	78	139	167	168	183	187	198
	Consumption	[kW]	6						
	Torque	[Nm]	44						
<b>1500 [rpm]</b>	Flow <sub>Wet</sub>	[m <sup>3</sup> /h]	193	230	220	240	242	253	254
	Flow <sub>Dry</sub>	[m <sup>3</sup> /h]	142	179	191	212	222	234	238
	Consumption	[kW]	7						
	Torque	[Nm]	41						
<b>1650 [rpm]</b>	Flow <sub>Wet</sub>	[m <sup>3</sup> /h]	226	259	234	260	269	276	334
	Flow <sub>Dry</sub>	[m <sup>3</sup> /h]	166	202	204	230	246	255	312
	Consumption	[kW]	8						
	Torque	[Nm]	43						
<b>1800 [rpm]</b>	Flow <sub>Wet</sub>	[m <sup>3</sup> /h]	244	280	253	276	289	291	359
	Flow <sub>Dry</sub>	[m <sup>3</sup> /h]	179	219	220	244	265	270	336
	Consumption	[kW]	9						
	Torque	[Nm]	48						

### 2.3.2 Pressure

	Pressure	[bar(g)]	0	0.25	0.5	0.75	1
<b>1200 [rpm]</b>	Flow	[m <sup>3</sup> /h]	182	165	148	120	83
	Consumption	[kW]	3	4	6	7.5	8.5
	Torque	[Nm]	24	32	48	60	68
<b>1500 [rpm]</b>	Flow	[m <sup>3</sup> /h]	277	260	244	219	151
	Consumption	[kW]	4	6	8	10	12
	Torque	[Nm]	25	38	51	64	76
<b>1650 [rpm]</b>	Flow	[m <sup>3</sup> /h]	300	282	272	256	239
	Consumption	[kW]	5.5	7.5	9.5	11	13.5
	Torque	[Nm]	32	43	55	64	78
<b>1800 [rpm]</b>	Flow	[m <sup>3</sup> /h]	325	309	287	277	266
	Consumption	[kW]	6.6	8.7	11	13	15
	Torque	[Nm]	35	46	58	69	80

The data Flow<sub>Dry</sub> is based on the following parameters:

- Air temperature 20°C
- Service liquid temperature 15°C
- Test performed with dry air and 1,013 mbar absolute pressure
- Tolerance ±10%

### 2.3.3 Correction factor – Temperature



Suction pressure and service liquid temperature to be adjusted in such way that cavitation cannot occur

When the temperature of the service liquid exceeds 15°C, the pump's capacity will be affected with respect to the specified values.

To determine the output at a higher temperature, the correction factor can be used.

Capacity at service liquid temperature higher than 15°C :

$$Q_{t>15} = Q_{15} \times K_1$$

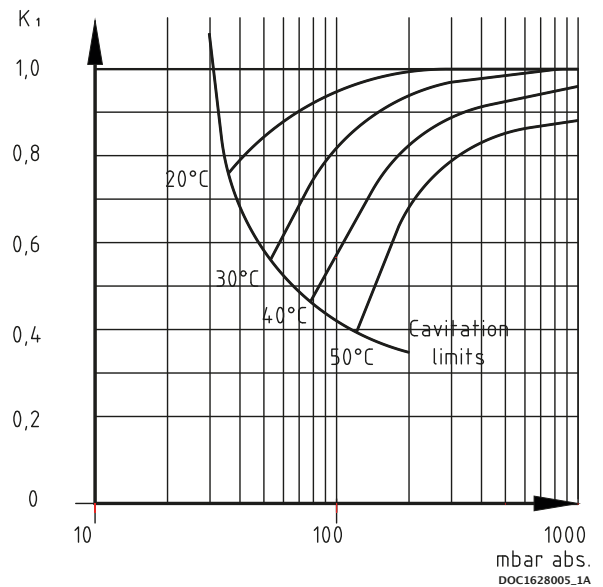

### 2.3.4 Correction factor – Wet and dry gas

Normal atmospheric air contains water vapor. In this case water will condense inside the pump and will create a higher flow.

Below you can find a correction factor table for the performance based on condensing gas with an inlet temperature of 50°C 100% saturated and service liquid temperature of 15°C.

Suction pressure % Vacuum	80	70	60	50	40	30	20
Correction factor wet gas $K_{Wet}$	1,34	1,28	1,15	1,13	1,09	1,08	1,07

The performance of the pump can thereby be calculated as:

$$V_{Wet} = V_{Dry} \times K_{Wet}$$

## 2.4 Handling and transport



The pump must not be used if it is damaged or the identification plate is missing  
ATEX marking must correspond to the area the pump is operating in

The pump must be transported in such way that it is not exposed to vibrations and impacts that can overload the bearings.

The pump must be inspected for damages upon delivery. If the pump is damaged, it must not be used and the damage must be reported to the manufacturer.

Ensure that the pump's identification plate is intact and that the marking of the pump corresponds to its use.

The pump must only be handled using approved lifting eyes, in accordance with nationally applicable regulations and only in a vertical motion.

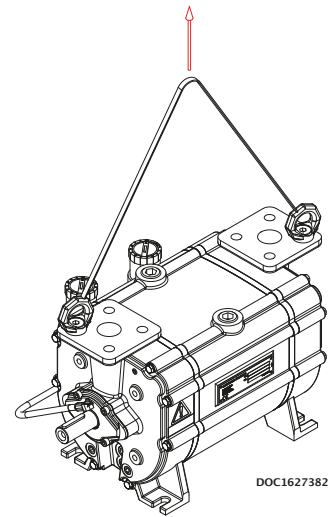

The pump can be transported in the following ways:

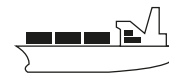

## 2.5 Pump storage and draining procedure



A failure to comply with the requirements for storing the pump may result in internal damage to the device



If the temperature is below freezing point of the service liquid, it could damage the pump. Under these conditions, the pump must be drained completely.



All plugs and protective covers must be fitted during storage.

The pump's service liquid is drained on delivery, and the pump can be immediately stored in accordance with the technical specifications.

After operation, the pump can be stored for 30 days without further action.

If the pump remains out of operation for a longer period of time after use, its service liquid must be drained, and the liquid supply to the pump must be shut off.

When emptying the pump, it is important that all chambers inside the pump are emptied.

The pump can be fitted with valves in the draining connections. See below.

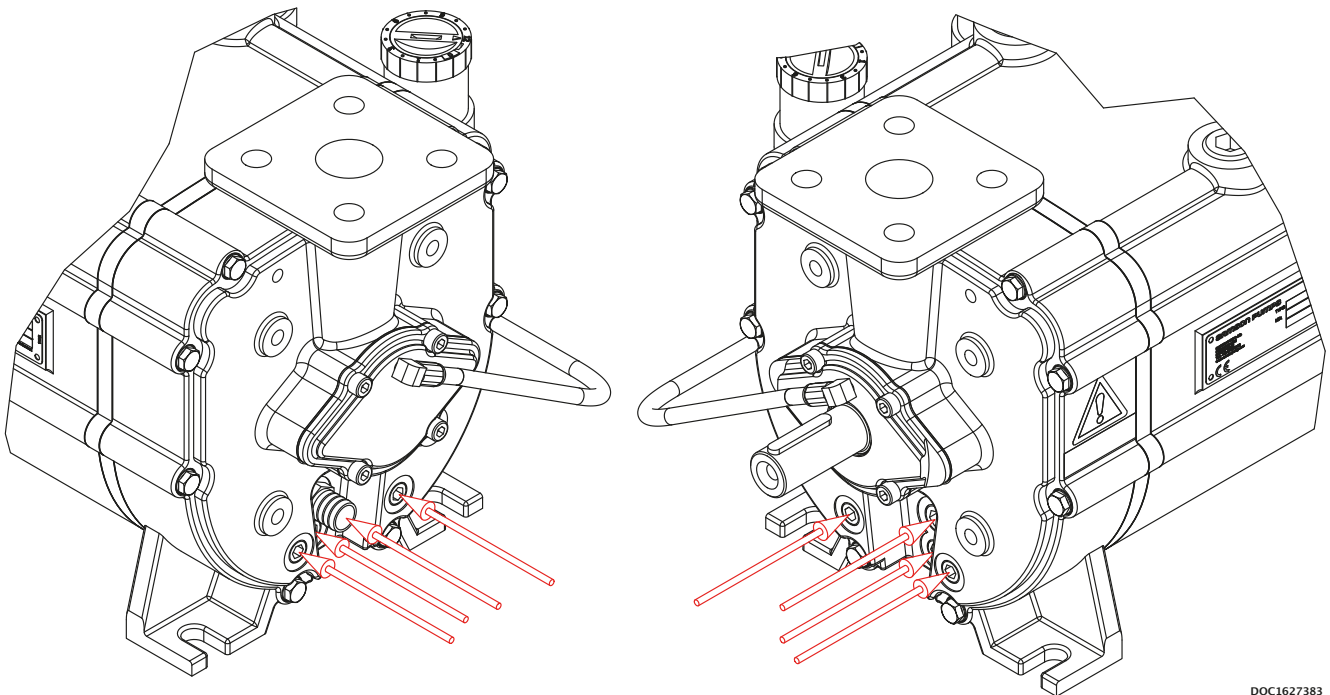

DOC1627383

### 3 DESIGN OF A SYSTEM

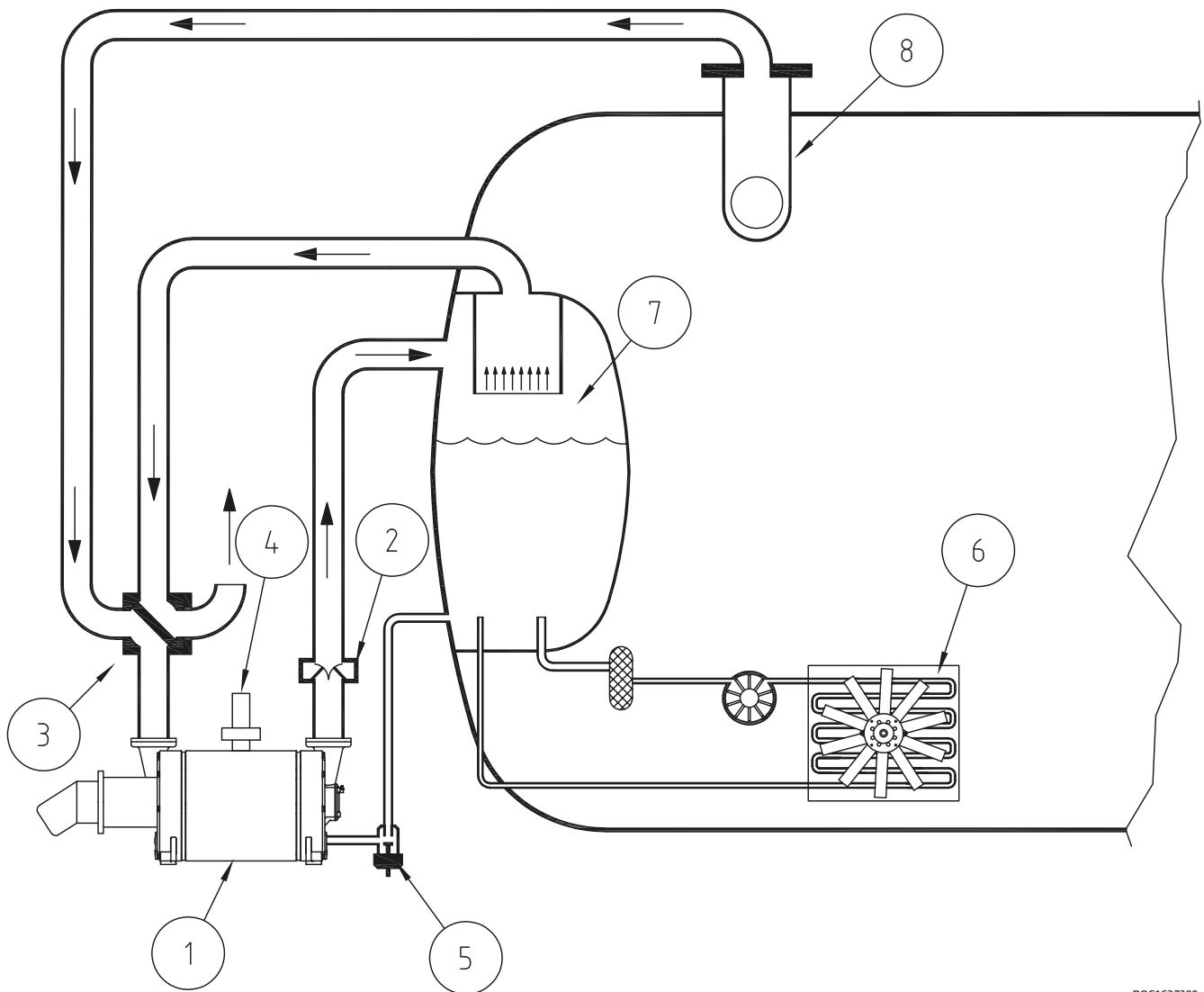

DOC1627390

Pos.	Description
1	Liquid ring pump
2	Non return valve
3	4-way valve
4	Vacuum limiter
5	Service liquid valve
6	Fan cooler
7	Liquid separator
8	Dome valve

### 3.1 Function and design of a liquid separator

Together with the air there will be a water flow out of the pump up to 6 m<sup>3</sup>/h.

The water will be separated from the air in the liquid separator.

Depending of the size of particles, water will be carried with the water when the air velocity is more than 3-4 m/s.

The inlet speed to the separator can be more than 50 m/s and this must be reduced to 3 m/s.

Below you find an illustration showing how to reduce the speed and control that no water will be in contact with the high velocity air stream. The round velocity reducer can be placed inside any tank geometry.

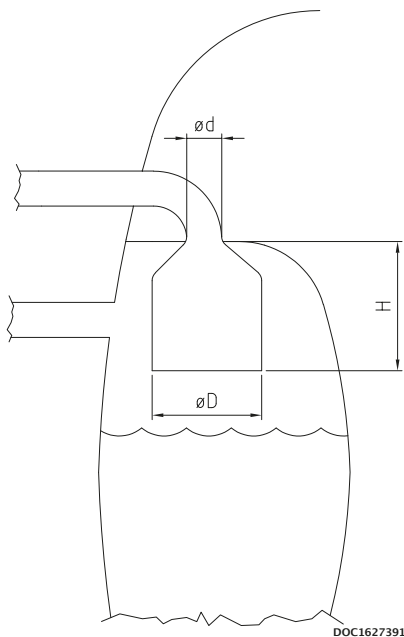

Air flow [m <sup>3</sup> /h]	$\varnothing D$ minimum [mm]
350	200
325	195
300	185
275	180
250	170
225	160

$\varnothing D$  so the velocity is below 3 m/s

$H=4$  to  $6 \cdot \varnothing d$  depending on the geometry. A smooth diameter conversion will give a low factor.

### 3.2 Air cooling with fan cooler

Compression of air inside the liquid ring pump will create heat that is transferred to the service liquid. Therefore, it can be necessary to install a fan cooler depending on the expected use, the climate etc. The time it takes to heat up the water also depends on for example ambient temperature, suction pressure, amount of water and the cooling effect in the truck itself.

The operation temperature will go up until there is a balance between the heat input and the heat output. So basically, there are only two things that can lower the operation temperature. Reduce the heat input or increase the heat output.

The amount of water has no or only a little influence on the final operating temperature. The truck itself will work as a big radiator and if there is a huge amount of water in the liquid separator and thereby good contact area between the water and the steel tank, it will give a higher cooling effect. This in combination with low ambient temperature and short time of operation, could mean that the truck can operate without any additional cooling.

In general, the time it takes to heat up the water can be calculated from the formula below.

$$t_{\text{sec}} = \frac{C_p \times m \times \Delta t}{Q}$$

$t_{\text{sec}}$  = Time in seconds

$C_p$  = Heat capacity of the media. Water= 4,2

$\Delta t$  = Temperature difference

$m$  = Mass of the media heating up [Kg]

$Q$  = Heat input in [kW] See specifications, chapter 2.2

Example:

We have a tank with 100 litres of water corresponding to 100 kg. The heat input is 8 kW. How long will it take to heat it up from 20°C to 40°C ?

$$t_{\text{sec}} = \frac{4,2 \times 100 \times 20}{30} = 1050 \text{ s} = \underline{17,5 \text{ min}}$$

The temperature will continue to go up until the steel construction can absorb the heat and transfer it to the surroundings.

With a temperature difference on 20°C it is typical to have a radiator effect in a truck on somewhere between 1 to 4 kW depending on the construction.

The table below shows truck radiator effect at a temperature difference of 20°C.

1 kW	2 kW	4 kW
Small liquid separator mounted external from the truck tank Water content below 20 L	Small liquid separator inside slurry tank. Located with only minor contact to the product Water content 50 L	Normal liquid separator inside slurry tank with good contact to the product Water content 100 L



---

### 3.3 Fan cooler

The fan cooler will increase the heat output from the construction and thereby stabilize the temperature at a lower level. However, this cooler will use the air to cool down the water and therefore we will always see that the temperature will be stabilized above the ambient temperature. It's very simple to find the right cooler based on the curves from the cooler manufacturer. Typically you will find the cooler capacity as kW/Δt meaning for example 1.5 kW cooler capacity each °C in temperature difference between the water and the air. Note that the water flow through the cooler will also affect the cooling capacity.

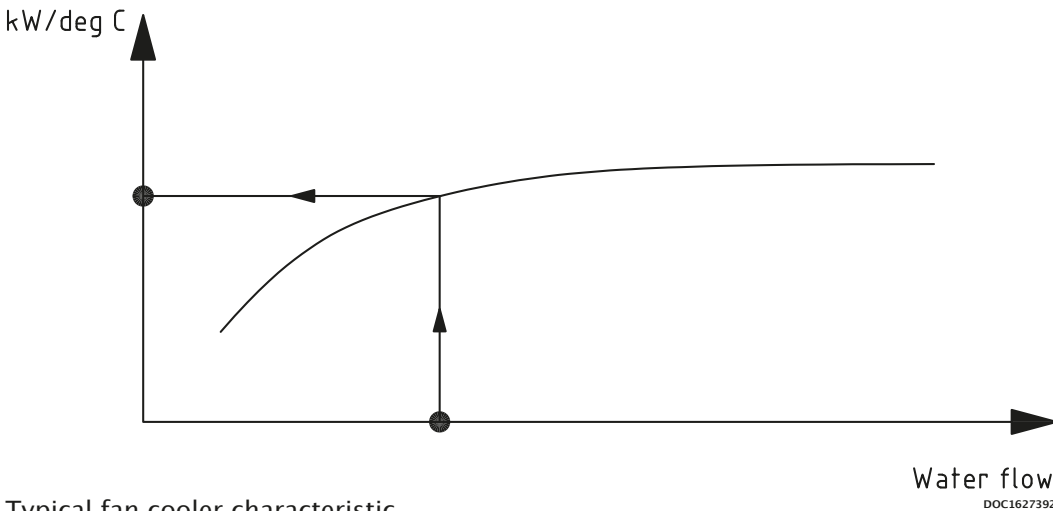

Typical fan cooler characteristic.

Practical calculation example:

The truck is used mostly to work with an operation pressure around 70% vacuum. From the technical data sheet, we find the heat input from the pump to be 6 kW.

The liquid separator is built inside the slurry tank with a good contact to the product and a radiator effect estimated to 4 kW with a temperature difference of 20°C.

The truck will work with ambient temperature up to 28°C during the summer and we will accept a maximum temperature on 40°C.

First, we have to reduce the radiator effect based on a temperature difference of 12°C.

$$Q_{\text{out Truck}} = 4 \times \frac{12}{20} = 2,4 \text{ kW}$$

The total cooling effect required is thereby:

$$Q_{\text{out Pump}} - Q_{\text{out Truck}} = 6 - 2,4 = \underline{3,6 \text{ kW}}$$

## Summary

Pump model	Description	Truck Master 350
Heat input from technical specifications	$Q_{in Pump}$	6 kW
Ambient temperature	$t_{amb}$	28°C
Maximum Working Temperature of the water. This is determined by you. The temperature has influence on the pump performance	$t_{op}$	40°C
Temperature difference	$\Delta_t$	$t_{Op} - t_{amb} = 12^\circ\text{C}$
Truck radiator effect based on 20 °C in temperature difference	$Q_{out Truck 20}$	4 kW
Truck radiator effect based on 12 °C in temperature difference	$Q_{out Truck 12}$	$4 * 12 / 20 = 2,4 \text{ kW}$
Total cooling requirement from fan cooler	$Q_{fan cooler}$	$Q_{in Pump} - Q_{out Truck 12} = 6 - 2,4 = 3,6 \text{ kW}$

We need to find a fan cooler that can transfer 3,6 kW with a temperature difference on 12°C. That is 0,3 kW/°C.

If we for example accept a higher temperature, for instance 48°C, we will have full cooling effect from the truck on 4 kW and a cooling requirement on 2 kW. The fan cooler we need to find is thereby on  $2/20 = 0,1$  kW/°C and a big difference to the bigger model calculated above.

---

### 3.4 Water consumption

It is possible to design the liquid separator so that almost 100% of the water is separated from the air. However, the air will be heated up and thereby it can contain more water. Also, the relative humidity will go up and end near 100%.

So, the air will flow into the pump with maybe 50% relative humidity at a low temperature and be discharged at a higher temperature and humidity. Therefore, there will be an evaporation from the system.

Choose your water temperature

Temp. \ Vacuum	20°C	30°C	40°C	50°C	55°C
50%	4	9	14	23	36
70%	3	4	8	13	21
80%	1	2	3	5	9

Water consumption Liters per hour

### 3.5 Dome valve system

The liquid ring pump can handle liquid and particles in the inlet but it is of course recommendable to avoid this.

A dome valve or floating valve will ensure that the suction will be closed when the liquid level reaches the top of the tank.

In many situations there will be foam on the liquid surface inside the tank. It can be difficult to avoid that this will be transported into the suction line before the dome valve will close.

Therefore, it will be recommended to make a combination of a filter and dome valve as illustrated below.

The filter will prevent particles lifted by the foam to enter the pump.

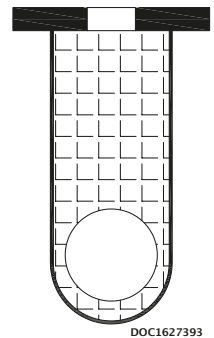

### 3.6 System layout (Zone 0/1)



To safeguard the pump so that it can operate in potentially explosive areas, the components used in the safety device must stop the pump in the event of abnormal operation



The maximum working pressure must not exceed specifications, by installing a safety valve

The pump must be fitted with the safety device components specified in drawing below.

The service liquid connection that feeds service liquid to the pump must be fitted with flow meters in positions 8 and 9, on both valve inlets.

To prevent the loss of service liquid, stop valves should be installed between the liquid separator and the pump. See Pos. 10 and 11. These valves must be closed when the pump is not in operation. The opening of the valves must be performed automatically when the pump starts.

Max. 1 m after the pump, a temperature sensor must be installed in position 7, which also serves as a safety device and which must stop the pump if the output temperature exceeds the limit.

The liquid level in the liquid separator must be monitored by a level sensor at position 6, which also stops the pump in the event of an insufficient level of liquid.

The 2 temperature sensors are placed in existing M10x1 threaded holes in the bearing housings. This is done by unscrewing existing plugs and mounting sensors instead. See illustration below.

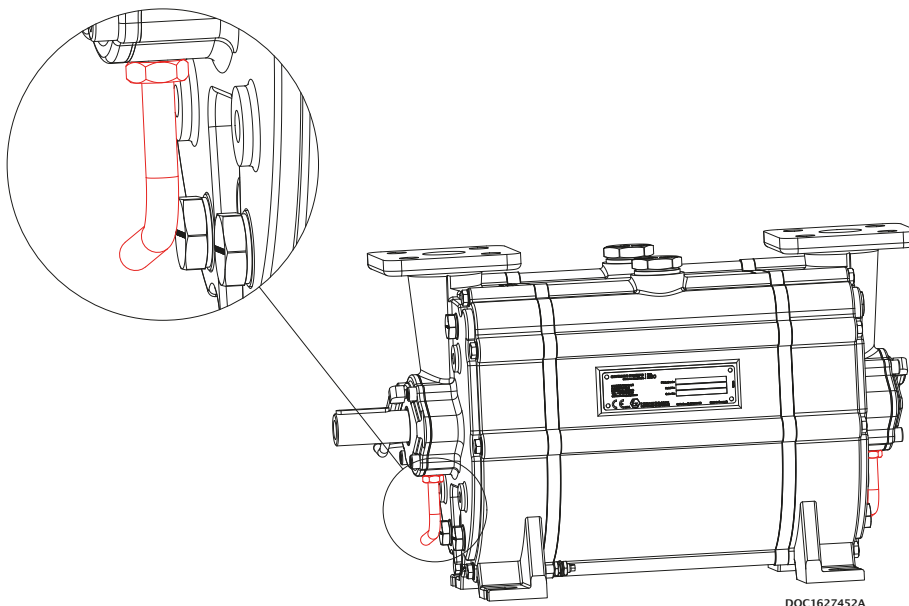

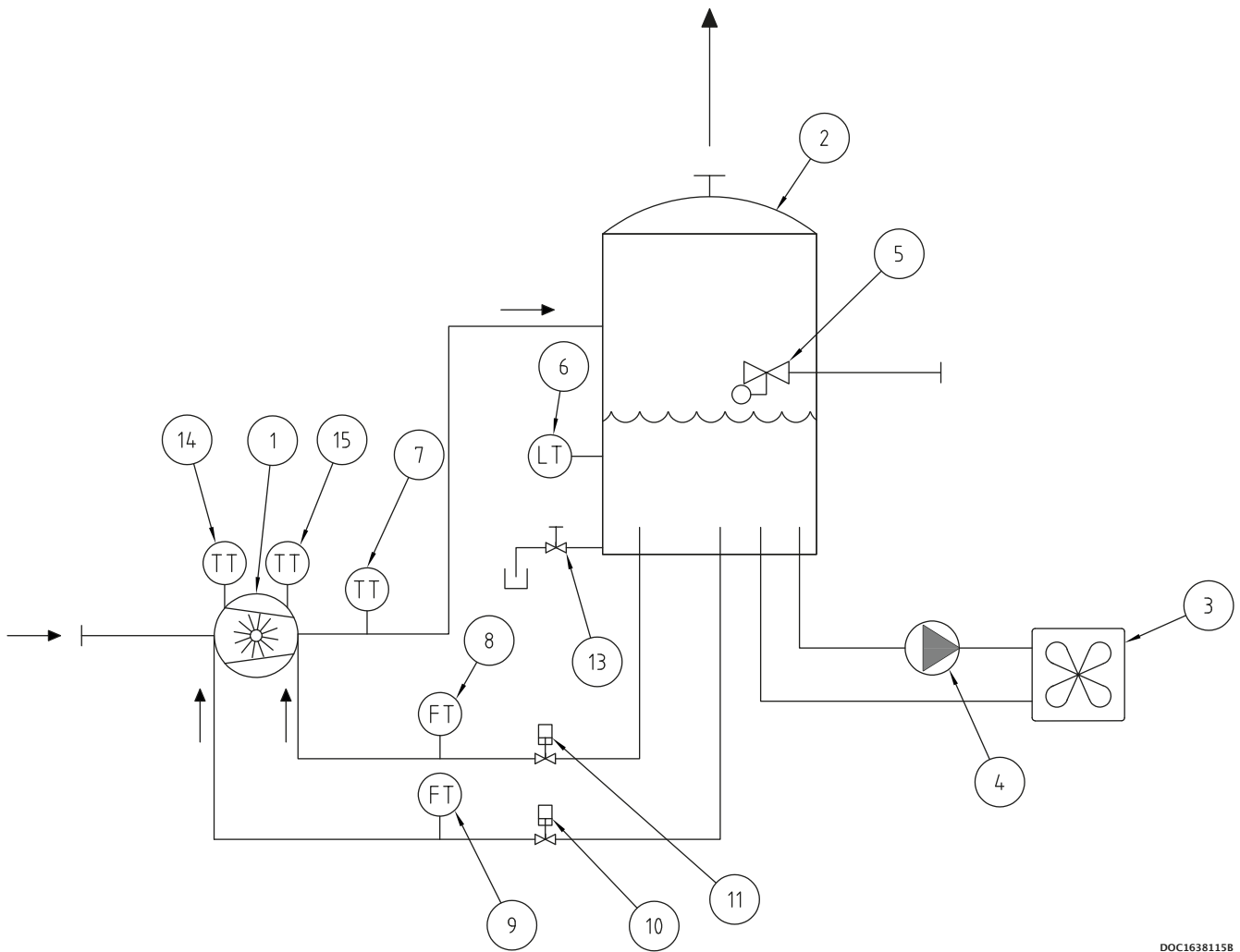

DOC16381158

Pos.	Description		Set
1	Vacuum pump		-
2	Liquid separator		-
3	Cooler or heat exchanger		-
4	Circulation pump		-
5	Float valve		-
6	Level switch	safety device	Min. 50 L
7	Temperature transmitter	safety device	Max. 60°C
8	Flow meter	safety device	Min. 2 L/min. max. delay 30 sec.
9	Flow meter	safety device	Min. 2 L/min. max. delay 30 sec.
10	Stop valve		-
11	Stop valve		-
13	Drain valve		-
14	Temperature transmitter DE	safety device	Max. 70°C
15	Temperature transmitter NDE	safety device	Max. 70°C

### 3.6.1 Safety Integrity Level (SIL) according IEC 61508

Description of Hazard	Position (Sensor)	Safety action required	SIL requirement to safety function
Increased temperature due to absence of service liquid for mechanical shaft seal, NDE	Pos 6 (Level) & pos 8 (Flow)	Stop of pump	SIL2
Increased temperature due to absence of service liquid for mechanical shaft seal, DE	Pos 6 (Level) & pos 9 (Flow)	Stop of pump	SIL2
Unacceptably elevated temperature in pump due to increased temperature of media	Pos 7 (Temperature in media)	Stop of pump	SIL2
Unacceptably elevated temperature of bearing, DE	Pos 14 (Temperature in bearing)	Stop of pump	SIL2
Unacceptably elevated temperature of bearing, NDE	Pos 15 (Temperature in bearing)	Stop of pump	SIL2

See page 21 for diagram.

### 3.7 Liquid separator



Liquid separator must be mounted in such way that the minimum level of service liquid is minimum 0,5 m above the pump´s shaft



When operating the drain valves, the outlet may contain explosive gases, corresponding to the classification of the pump´s suction side

The liquid separator must be located in immediate proximity to the pump, so that the length of the outlet pipe from the pump is minimised. Due to potential pressure loss, the length may not exceed 2 metres. The level of liquid in the liquid separator is recommended to be kept at 1–1.5 metres above the pump's shaft. This ensures the correct influx pressure and the correct flow of service liquid.

The liquid supply between the liquid separator and pump must be implemented with a permanent pipe connection with a dimension and length specified in specifications.

It may be advantageous to fit the liquid separator with a float valve which automatically supplies liquid and maintains a constant level.

The liquid separator can be fitted with a drain valve at the lowest place in the tank. The valve can be operated when the separator needs to be drained to remove contaminants.

---

### 3.8 Cavitation

When the temperature reaches the boiling point of the water, steam bobbles will be created in the liquid ring.

These bobbles cannot exist when they enter the discharge side of the pump and therefore they will collapse. The impact force on the surface of the rotor and flow plate will damage the pump and can lead to a total breakdown. It is a very harmful situation that must be avoided.

It is the combination of the pressure and the temperature that will lead to the cavitation. Therefore, it is recommended to install a cavitation valve, see illustration below that shows a clockwise rotating pump. If counter-clockwise rotating pump, mount in opposite hole.

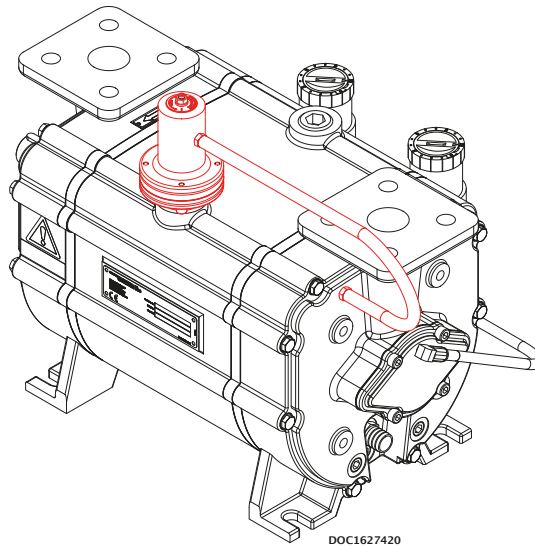

Below you find the boiling point of water as a function of the pressure.

Vacuum	50%	75%	80%	90%
Temperature °C	80	64	59	44
Maximum discharge temperature	70	50	40	30

Note that the temperature of the gas inside the pump will heat up the water and the water surface therefore will become a higher temperature than the measured temperature on the discharge side of the pump. Cavitation will therefore start at a lower temperature and the maximum discharge temperature of the water must be kept lower.

### 3.9 Service liquid requirement

During operation it is normal that small amount of product will enter the pump, or the gas will react with the water which becomes aggressive.

A normal recommendation is to add glycol to the water in order to protect the liquid ring pump. Glycol will protect the pump and for example the aluminum cooler, but shall only be used in periods with temperature below freezing point.

Due to economical aspect it is more efficient to drain the liquid separator and refill with fresh water instead of protecting with glycol and drain the separator more rarely.

---

### 3.10 Pipe system



The exhaust from the liquid separator will have the same zone classification as the pump's suction side

The pipes that are connected to the pump's suction and outlet sides must be at least the same dimension as the pump. The length of the pipe system affects the pump's capacity and should be calculated to account for pressure drop in longer pipe installations.

Depending on the operating pressure, longer pipe lengths may affect the pump's output. For pipe lengths greater than 10 metres, a pressure drop calculation should be made, and the pipe dimensions should be increased so that the pressure loss is held to an acceptable level.

The pipe system should be mounted so that the horizontal pipes have a min. of 1% decline back towards the liquid separator.

Table below can be used for reference values.

Connection	Length < 10 metres	Length 10–50 metres	Length 50–100 metres
Suction side	Min. DN 40	Min. DN 50	Min. DN 65
Outlet side	Min. DN 40	Min. DN 50	Min. DN 65

The outlet from the liquid separator should be led outside of the building because the outlet air is warm and humid.

With respect to the exhaust, measures must be put in place to account for damp air that may form ice in cold surroundings.

### 3.11 Suction filter

In installations where there is a risk of sucking foreign elements into the pump, a filter must be mounted on the pump's suction side with a maximum mesh size of 2 mm.



# 4 INSTALLATION AND START-UP

## 4.1 Securing the pump



Installation requirements must be observed, otherwise there is a risk of damage and of potential explosion

The pump must be installed on a stable foundation, which must be level and stable, so that the pump is not twisted or exposed to a profile distortion.

The pump must be installed with M12 bolts on all four legs, which must be tightened to 60 Nm (A).

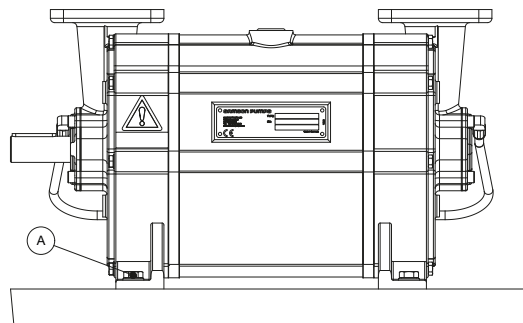

DOC1627384

## 4.2 Connections to the pump



- Check for foreign objects in the pump and physical damage on pump
- Gaskets to be handled with highest degree of caution
- Gasket and sealing surfaces must be cleaned before assembly



External effects on the pump may lead to leakage and, as a result, a potential risk of explosion

Immediate before connecting the pipes, remove protective covers. Connection of the pump's suction and pressure pipe connections must be made with a gasket in between (C).

The M12 bolts must be tightened with 60 Nm (B).

In order to prevent tensions in the pump, the pipe connections (A) must be tensionless while tightening the bolts.

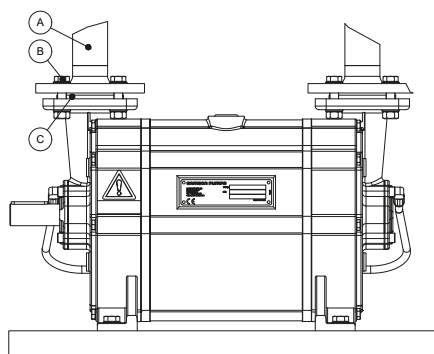

DOC1627384\_1

### 4.3 Connecting the service liquid

The service liquid must be connected to the pump at the hose connections, see illustration below.

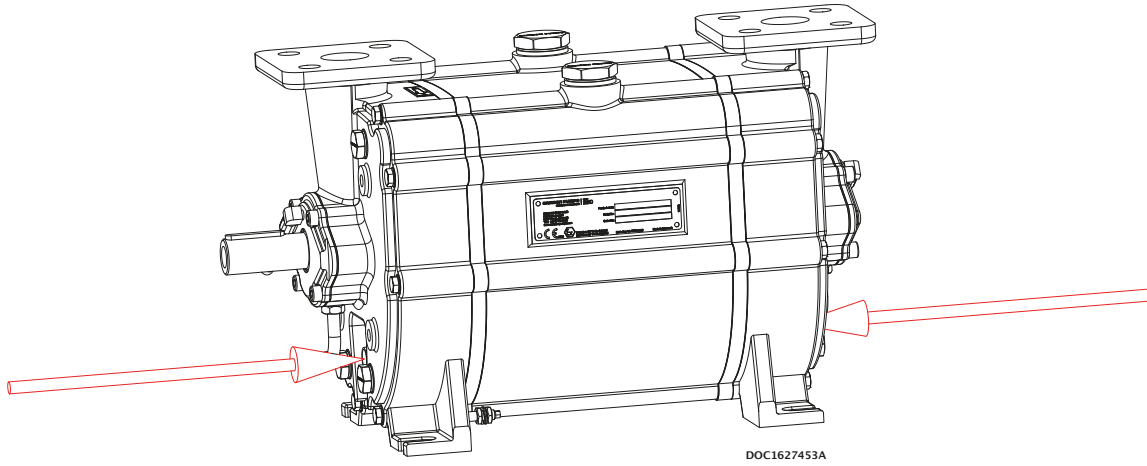

### 4.4 Transmission

The pump can be connected direct or through belt transmission. For belt transmission, it must be ensured that the permissible radial force is not exceeded. See specifications.

For belt transmission, note the direction of rotation, see illustration below.

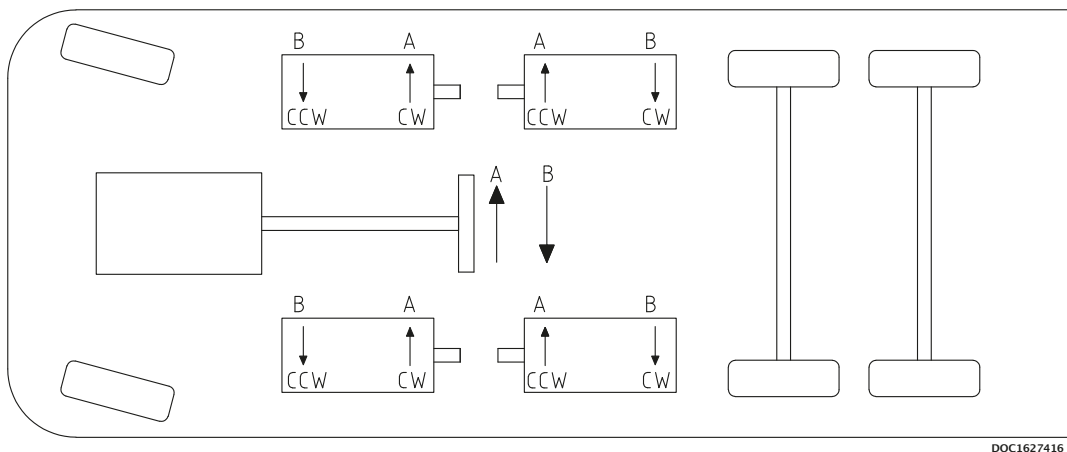

---

## 4.5 Earth connection requirements



The pump must be connected to earth to prevent static electricity. Static electricity is a potential source of ignition.

The pump must be protected from the creation of sparks in connection with static electricity, in accordance with the applicable regulations for use in the current categories.

The pump is prepared for earth connection with an M8 bolt.

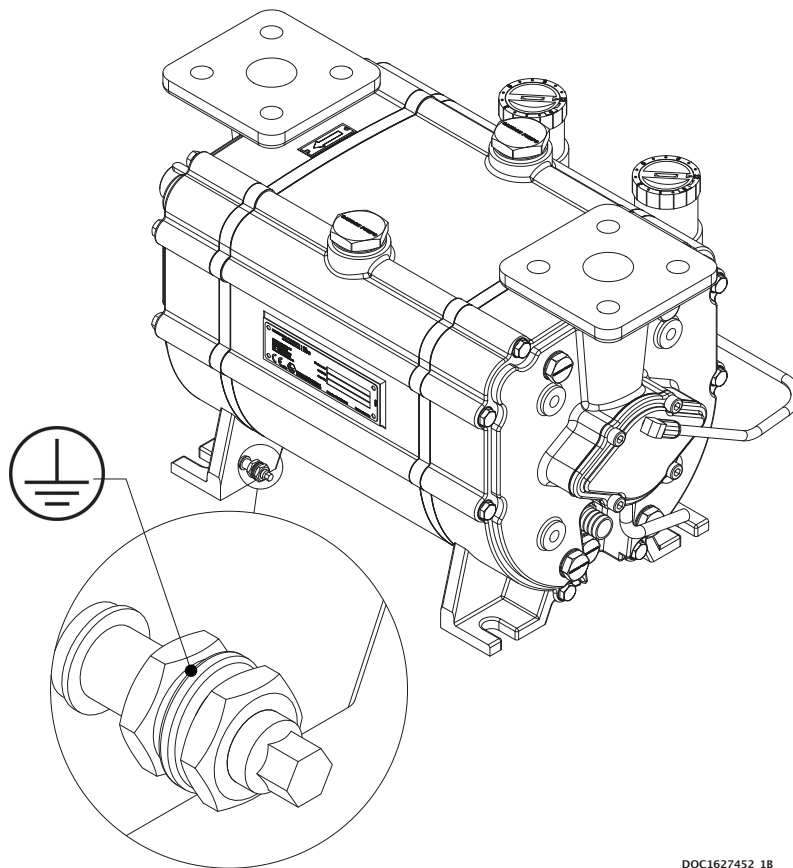

DOC1627452\_1B

## 4.6 Prior to start-up



- Do not start the pump without service liquid, as this will damage the mechanical shaft seals
- Do not start the pump if it is completely filled with service liquid
- Do not start the pump before the grease cartridges have been activated, as this can damage the pump
- Stop the pump immediately if the rotational direction does not correspond to the directional arrow
- A failure to follow the above guidelines may result in damage to the pump

### Activating the grease cartridges

Turn the handle in NDE clockwise to position 12.  
Turn the handle in DE clockwise to position 12.  
The pump has been lubricated from factory and is ready to start.

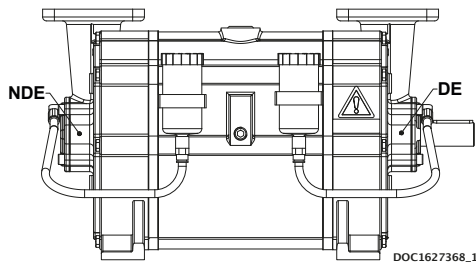

## 4.6 Direction of rotation

Check the direction of rotation by briefly starting the pump.

The direction of rotation of the rotor must correspond to the direction arrow!

Below left, a right-side pump is shown which has a clockwise direction of rotation (CW)

Below right, a left-side pump is shown which has a counter-clockwise direction of rotation (CCW)

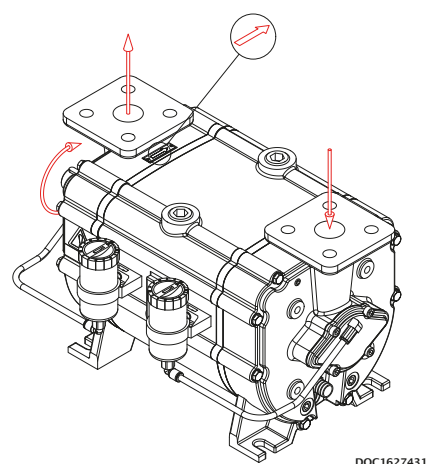
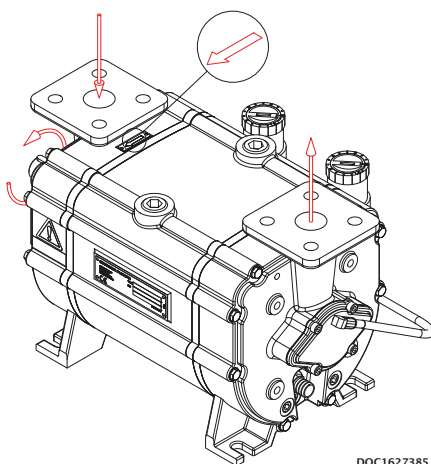

# 5 SERVICE, OPERATION, MAINTENANCE AND INSPECTION INTERVALS



A failure to observe the inspection intervals described in table below may result in damage to the pump and a potential risk of explosion

Section	Operation	Interval
5.1	Inspection of bearings	Daily
5.2	Visually inspect for leakage	Weekly
5.3	Drain liquid separator to remove contaminants	Weekly
5.4	Check grease cartridges	Weekly
5.5	Inspection of ATEX safety device	Monthly
5.6	Inspection and cleaning (if necessary) of service liquid's supply pipe	Monthly
5.7	Calibration of ATEX safety device	Annually
5.8	Overhaul of pump	10,000 duty hours
5.9	Winterization	When below 0°C
6	Troubleshooting	As required

## 5.1 Inspection of bearings

The bearings of pump must be inspected once a day.

Be alert of unfamiliar sounds from bearing.

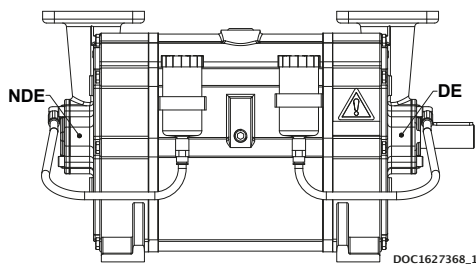

## 5.2 Inspecting for leakage

The pump and pipe system around the pump must be inspected for leakage once a week. The inspection must be performed when the pump is both operating and idle. Any leaks must be repaired before operation may continue.

## 5.3 Draining the liquid separator

While the pump is stopped, the liquid separator must be drained to remove contaminants.

---

## 5.4 Check grease cartridges



To prevent electrostatic discharge in hazardous areas, only wet cleaning is permitted. Appropriate measures must be taken to prevent electric discharge.

Automatic lubrication must be inspected and replaced as needed.

When the pump is commissioned for the first time, the cartridges must be activated by turning the arrow in the clockwise direction.

The cartridge is set to 12, which corresponds to an emptying time of 12 months. The cartridge must be replaced when empty.

It is only allowed to use automatic lubricator of type **LAGD 125/WA2**.



## 5.5 Inspection of ATEX safety device



ATEX safety device must be inspected in accordance with table to ensure proper functionality. A failure to perform the required inspections will result in the discontinuation of the pump's approval.

Safety devices to be inspected in accordance with applicable regulations.

The components that make up the safety device can be found in the system layout.

## 5.6 Inspection and cleaning of service liquid's supply pipe

The pipe connection between the liquid separator and pump must be inspected at least once a month, and any contaminants must be removed.

## 5.7 Calibration of ATEX safety device

The flow and level meter must be calibrated once a year in accordance with the applicable requirements. The pump may not be started before the instruments have been re-installed.

## 5.8 Overhaul of pump

The pump must be serviced after 10,000 duty hours. This is done by sending the pump to Samson Pumps, or approved and certified partner, upon agreement. The pump must be cleaned before shipment.

Repairs carried out on ATEX pumps may only be performed by Samson Pumps, or approved and certified partner. If this requirement is not observed, and the pump's seal is broken, the pump's declaration of conformity is not valid and Samson Pumps is no longer responsible for any resulting consequences.

## 5.9 Winterization

If the pump needs to be used at a temperature below freezing point of the service liquid, it is necessary to protect the liquid from freezing by adding anti freeze liquid.

# 6 TROUBLESHOOTING

Problem	Cause	Effect	Corrective measure
<b>The pump is unable to create a vacuum</b>	<ul style="list-style-type: none"> <li>• Service liquid valve is closed</li> <li>• The pump is not receiving enough service liquid</li> <li>• The temperature of the service liquid is too high</li> </ul>	<ul style="list-style-type: none"> <li>• Reduced output</li> <li>• The pump can become damaged during cavitation</li> </ul>	<ul style="list-style-type: none"> <li>• Check service liquid valve</li> <li>• Check the liquid supply</li> <li>• Stop the pump and wait until the temperature has dropped to a sufficient level, or lower the temperature of the service liquid inlet</li> </ul>
<b>The start-up power is too high</b>	<ul style="list-style-type: none"> <li>• Too much service liquid in the pump prior to start-up</li> </ul>	<ul style="list-style-type: none"> <li>• Noise at start-up and possible overload of the power supply</li> </ul>	<ul style="list-style-type: none"> <li>• Check the stop valves in the liquid supply for leakage</li> </ul>
<b>Noise during operation</b>	<ul style="list-style-type: none"> <li>• Cavitation</li> </ul>	<ul style="list-style-type: none"> <li>• Severe damage to the pump and potential risk of breakdown</li> </ul>	<ul style="list-style-type: none"> <li>• Increase the suction pressure or lower the temperature of the service liquid</li> </ul>
<b>Leakage from the bearing housing's drain holes</b>	<ul style="list-style-type: none"> <li>• Damaged shaft seal</li> </ul>	<ul style="list-style-type: none"> <li>• Bearings may become damaged</li> <li>• Potential risk of explosive gas leak</li> </ul>	<ul style="list-style-type: none"> <li>• Stop the pump and contact the manufacturer</li> </ul>

# 7 SPARE PARTS AND TOOLS

## 7.1 Marking and identification

The pump is equipped with an identification plate as shown below.

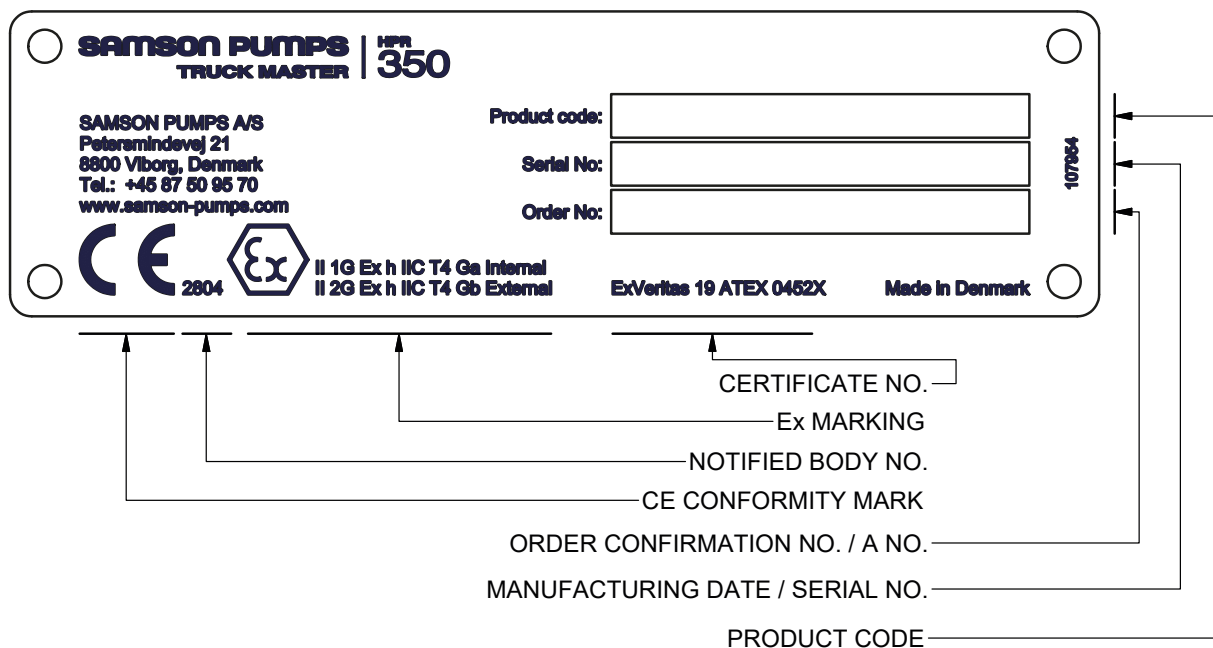

Configuration example:

**TM 350 R 0 S S B 1 0 T X5**

- Type: ←
- Model: ←
- Rotation: ←
- Rotor type: ←
- Pump housing: ←
- Shell: ←
- Flow plates: ←
- Generation of pump: ←
- Gaskets: ←
- Colour: ←
- Documentation: ←

Location of ID plate

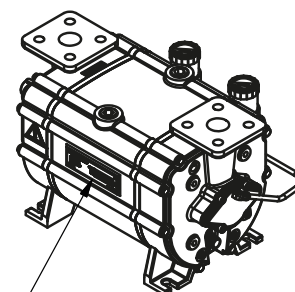

DOC107954C



## 7.2 How to order

Example:		TM	350	R	0	S	S	E	1	0	T	X5
<b>Model:</b>	350											
<b>Rotation:</b>												
Clockwise				R								
Counter clockwise				L								
<b>Rotor type:</b>												
Welded AISI 316					0							
<b>Pump housing:</b>												
Cast iron EN-GJL-250; EN1561						S						
<b>Shell:</b>												
Cast iron EN-GJL-250; EN1561							S					
<b>Flow plates:</b>												
Stainless steel AISI 316								E				
<b>Generation of pump:</b>												
1 or 2									1			
<b>Gaskets:</b>												
Oakenstrong										0		
<b>Colour:</b>												
Grey primer											P	
Truck Master Orange												T
On request												X
<b>Documentation:</b>												
ATEX Zone 0												X5

### 7.3 Spare parts

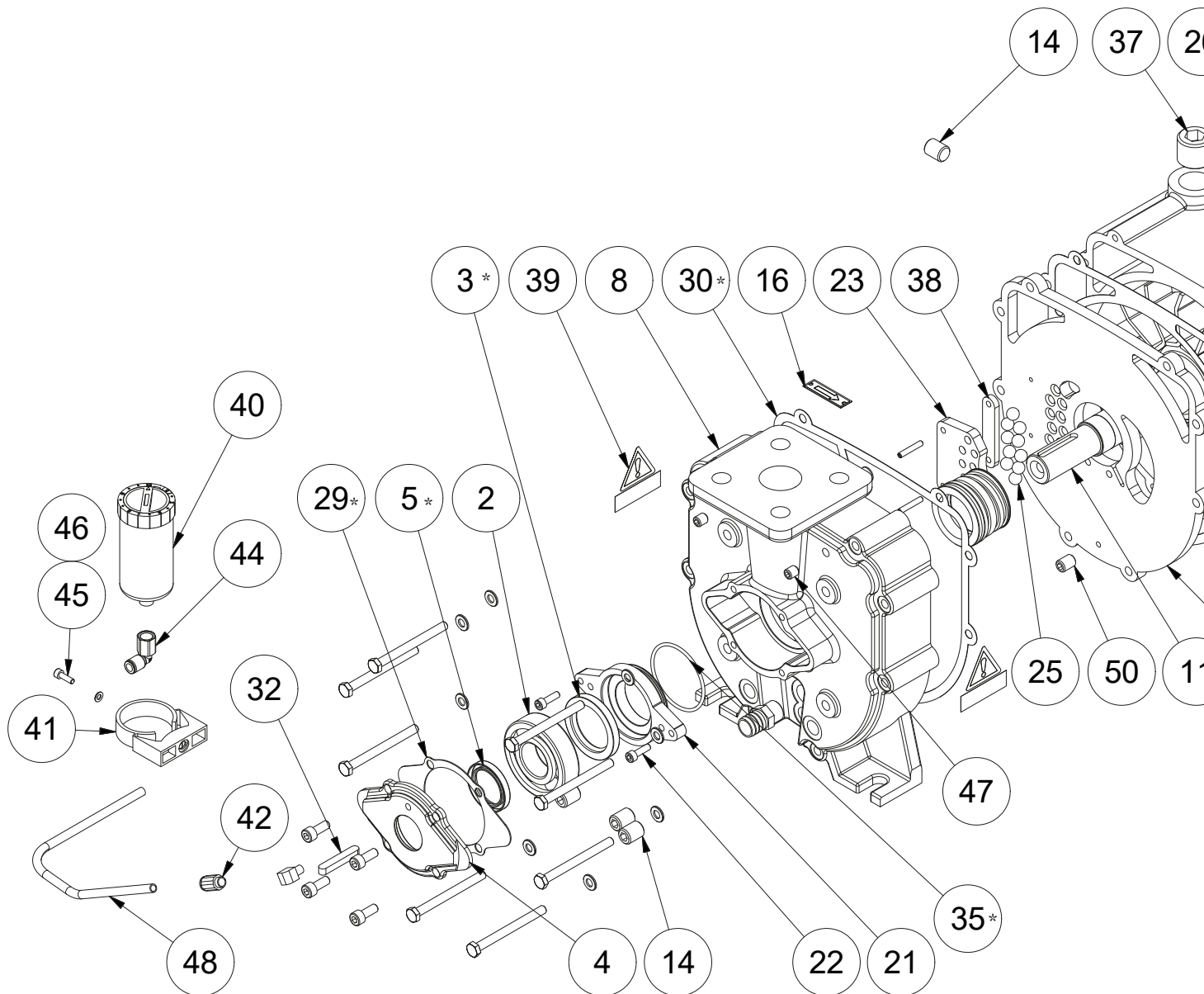

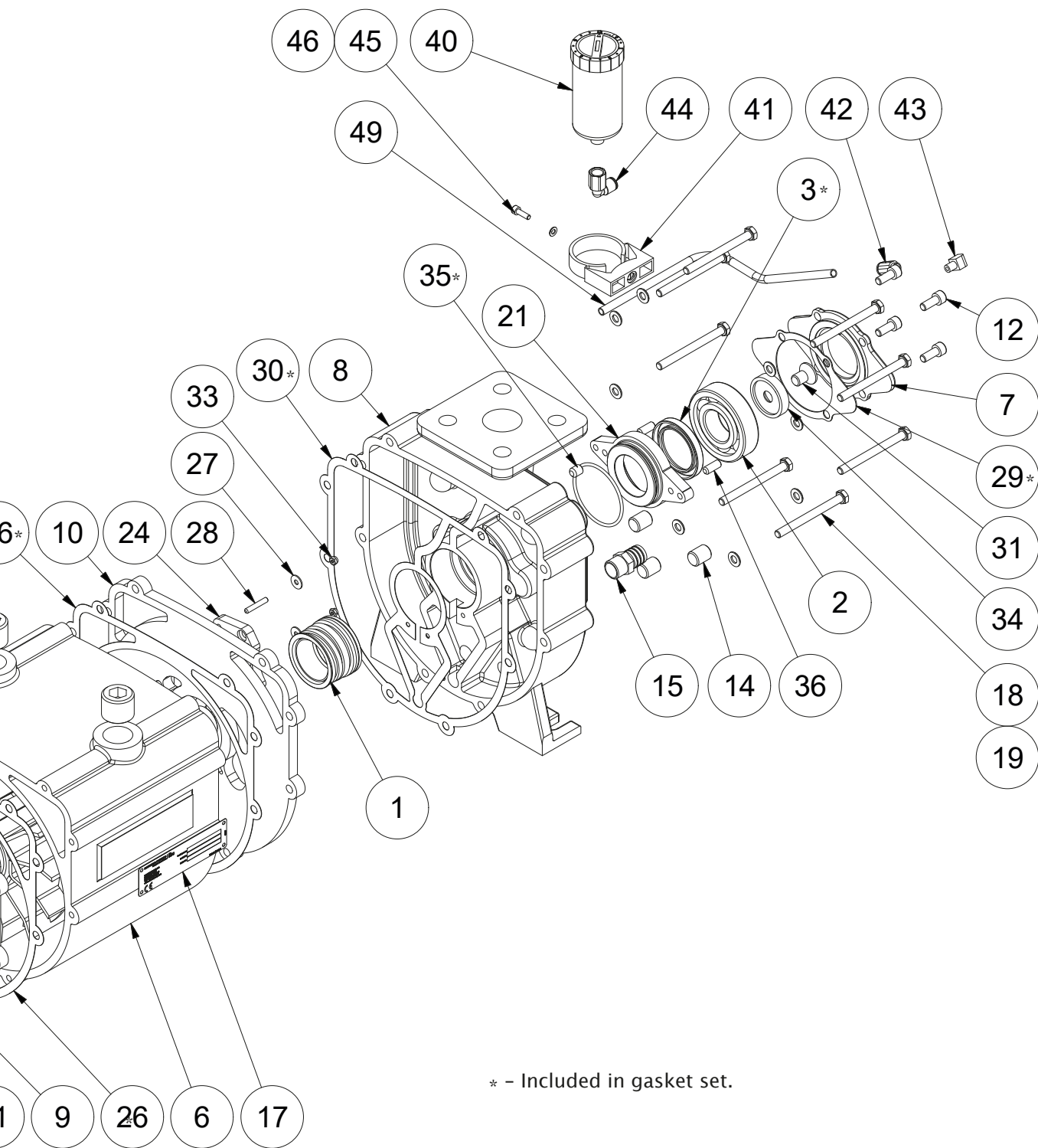

DOC1627450

Pos.	Part number	Description	Qty.	Material
1	922000042	Mechanical shaft seal	2	NBR / AISI 316 / Carbon
2	930000078	Ball bearing	2	Chrome steel W.Nr. 1.3505
3	1600003	Gasket set Truck Master 350	1	-
4	1622072	Bearing cover DE	1	Cast iron EN-GJL-250, EN 1561
5	1600003	Gasket set Truck Master 350	1	-
6	1622036	Shell	1	Cast iron EN-GJL-250, EN 1561
7	1622071	Bearing cover NDE	1	Cast iron EN-GJL-250, EN 1561
8	1622069	Pump housing	2	Cast iron EN-GJL-250, EN 1561
9	1622019	Flow plate	1	SS W.Nr. 1.4404
10	1622020	Flow plate	1	SS W.Nr. 1.4404
11*	1622107	Rotor R	1	SS EN 1.4418 / AISI 316L
	1622110	Rotor L	1	SS EN 1.4418 / AISI 316L
12	910300024	Allen screw	8	Steel DIN 912 FZB
13	910300184	Plug	1	Steel DIN 906
14	910300188	Plug	7	Steel DIN 906
15	925000246	Hose nipple	1	Brass
16	-	Direction arrow	1	Aluminum
17	-	Identification plate	1	SS AISI 316
18	910000020	Bolt	16	Steel DIN 931 FZB
19	910100007	Washer	16	Steel DIN 125B FZB
21	1622074	Adjustment plate	2	Cast steel W.Nr. 1.0446
22	910300447	Allen screw	6	SS AISI 316
23	1622024	Ball guide	1	Plastic PEHD 1000
24	1622025	Ball guide	1	Plastic PEHD 1000
25	962000047	Valve Ball	20	Plastic PPH100NA-20M
26	1600003	Gasket set Truck Master 350	1	-
27	910100149	Washer	4	SS AISI 316 D9021
28	910300446	Socket set screw	4	SS AISI 316 D916
29	1600003	Gasket set Truck Master 350	1	-
30	1600003	Gasket set Truck Master 350	1	-
31	910300459	Allen screw	1	Steel DIN 7991 FZB
32	915000210	Parallel key	1	Steel DIN 6885A
33	910200107	Lock nut	4	SS AISI 316 DIN 985
34	1622075	Washer	1	SS AISI 316

\* -See section 7.1 for identification of pump.

Pos.	Part number	Description	Qty.	Material
35	1600003	Gasket set Truck Master 350	1	-
36	910300125	Socket set screw	2	Steel DIN 916
37	910300182	Plug	2	Steel DIN 906
38	1622026	Spacer for ball guide	2	SS W.Nr. 1.4401
39	1624020	Sticker Warning!	2	Plastic foil FasCal 400
40	915000225	Automatic lubricator LAGD 125/WA2	2	Plastic PA6 / grease
41	915000232	Clamp for automatic lubricator	2	Plastic PA6
42	944600239	Push-in nipple	2	Brass
43	944600173	Elbow	2	Steel S235
44	944600240	Elbow	2	Plastic PBT / Brass
45	910300221	Allen screw	2	Steel DIN 912 FZB
46	910100002	Washer	2	Steel D125B
47	910300281	Plug	4	Steel DIN 906
48	915000217	Plastic pipe	0,3 m	Plastic PA6
49	915000217	Plastic pipe	0,3 m	Plastic PA6
50	910300183	Plug	1	SS AISI 316

\* -See section 7.1 for identification of pump.

## 7.4 Gasket set



DOC11592

Pos.	Part number	Description	Qty.	Material
3	922200051	Radial shaft seal 45x65x8	2	Rubber NBR DIN 3760A
5	922200022	Radial shaft seal 35x50x7	1	Rubber NBR DIN 3760A
	922200020	Radial shaft seal 35x47x7 (<2012)	1	Rubber NBR DIN 3760A
26	1622027	Gasket for shell / flow plate 0,4 mm	2	Paper Oakenstrong
	1622066	Gasket for shell / flow plate 0,8 mm	2	Paper Oakenstrong
29	1622076	Gasket for bearing cover 1 mm	2	Rubber NBR
	1622029	Gasket for bearing cover 0,4 mm (<2012)	2	Paper Oakenstrong
30	1622028	Gasket for pump housing / flow plate 0,4 mm	2	Paper Oakenstrong
35	922100361	O-ring Ø64,50x3,00	2	Rubber NBR

See spare parts drawing (DOC1627450) for positions.

## 7.5 Special tool set

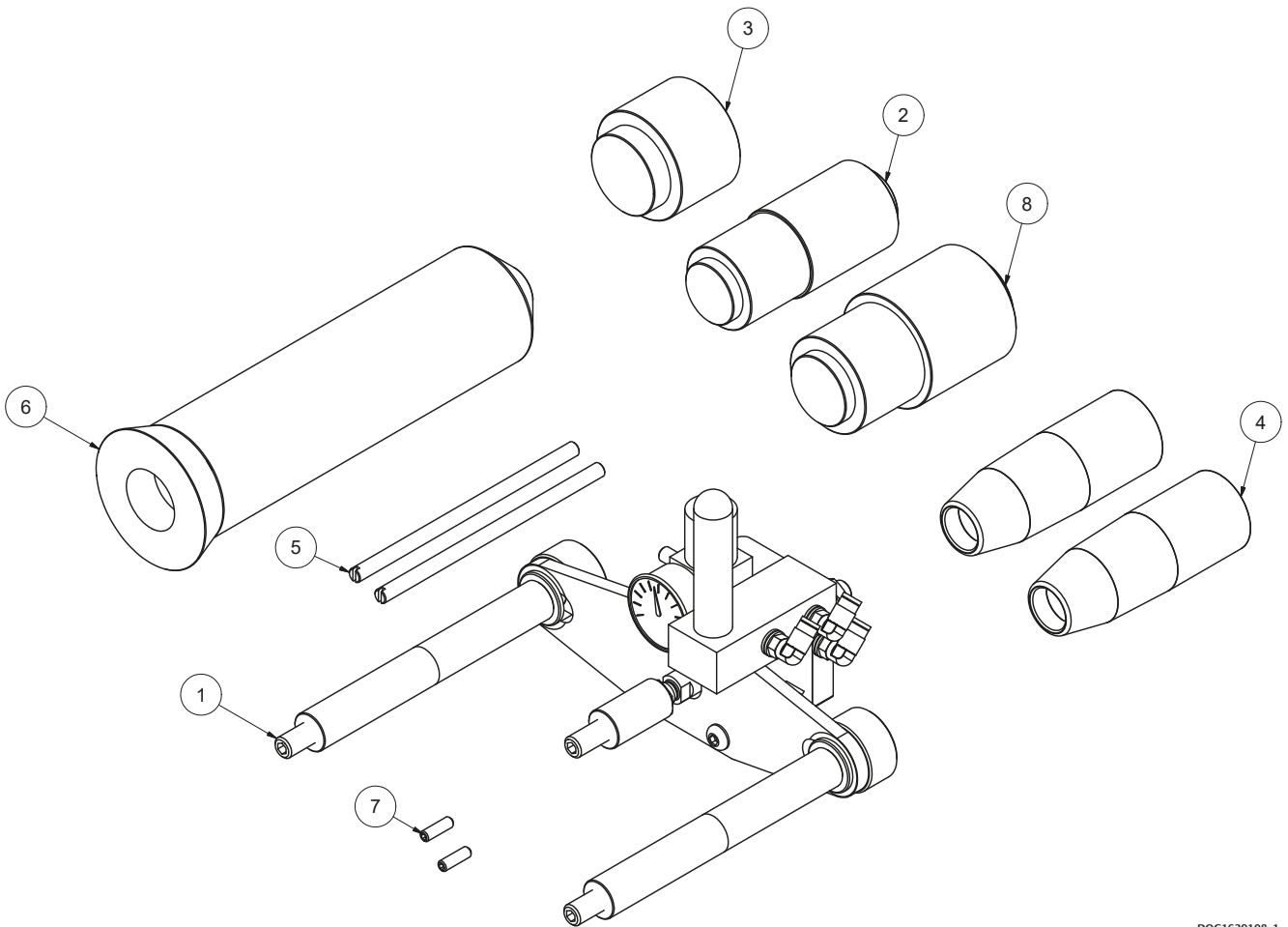

DOC1629198\_1

Pos.	Part number	Description	Qty.	Material
1	1629136	Bearing tool	1	Steel / Brass / Al / PA
2	1629195	Mandrel radial shaft seal Ø35	1	Plastic POM
3	1629197	Mandrel mechanical shaft ring	1	Plastic POM
4	1629098	Assembly bush	2	Plastic POM
5	1629194	Guide pin M8	2	SS AISI 316
6	1629192	Bearing mounting tool	1	Plastic / Aluminum
7	910300428	Socket set screw	2	SS DIN 916
8	1629196	Mandrel radial shaft seal Ø40 + Ø45	1	Plastic POM

**Notes:**



---

**Notes:**

---

---

---

---

---

---

---

---

---

---

---

---

---

---

---

---

---

---

**Notes:**

---

---

---

---

---

---

---

---

---

---

---

---

---

---

---

---

---



## **SAMSON PUMPS**

Samson Pumps is the only company in the world to specialise exclusively in liquid ring vacuum pumps. Samson pumps are made in Denmark and used around the globe. We offer worldwide delivery, and we export to more than 80 countries around the world.

For over 40 years, our name has been synonymous with the strongest pumps for vacuum trucks and tankers. We constantly adapt our products to meet the changing needs of our customers. Today, it is not enough to simply produce a pump. Products must be refined so the customer can concentrate on what they do best. We therefore offer a wide range of standardised components that allow our customers to build vacuum systems without the need for specialist in-house expertise.

Strength and durability are our hallmarks! We have often heard from customers that our pumps are working in many years, and in most cases without the need for maintenance or repair. This emboldens us to say that we have the strongest program of pumps on the market.