

## INSTRUCTION MANUAL

LIQUID RING PUMP

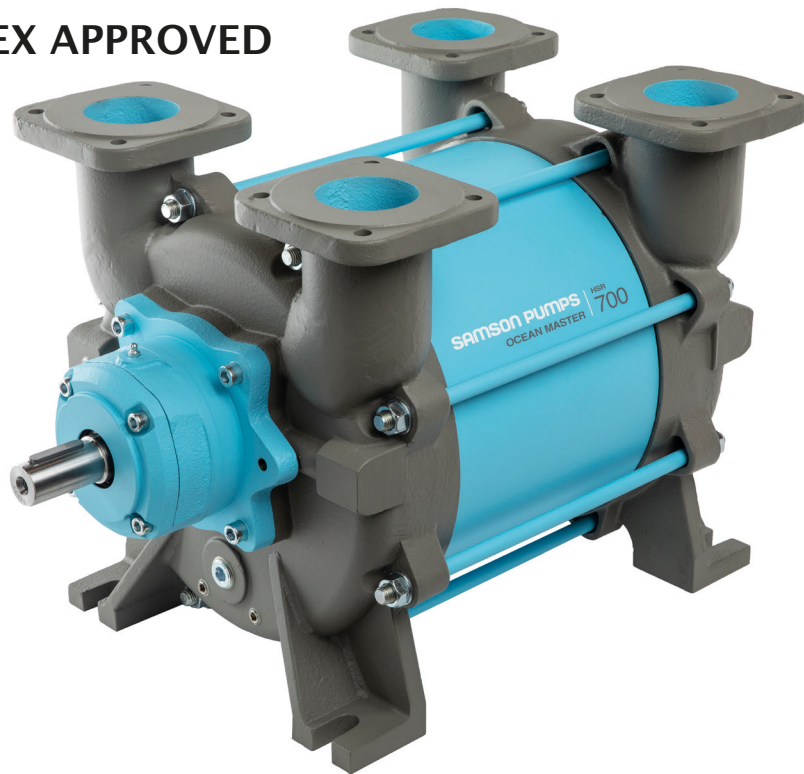

ATEX APPROVED



Zone 1 Internal / Zone 1 External

# OCEAN MASTER<sup>®</sup> 700

INSTRUCTION MANUAL FOR SAMSON LIQUID RING PUMP  
OCEAN MASTER 700

- 
- Technical data
  - Design of a system
  - System layout
  - Installation and start-up
  - Service
  - Troubleshooting

---

# CONTENTS

<b>1</b>	<b>Introduction .....</b>	<b>4</b>
1.1	Declaration of conformity.....	4
1.2	Explanation of warning symbols.....	5
1.3	Disposal.....	5
1.4	ATEX Directive 2014/34/EU .....	6
1.5	Field of application.....	7
<b>2</b>	<b>Technical data.....</b>	<b>8</b>
2.1	Dimensions.....	8
2.2	Specifications.....	9
2.3	Power consumption and output.....	10
2.3.1	Performance .....	10
2.3.2	Consumption .....	11
2.3.3	Correction factor - Temperature .....	12
2.3.4	Correction factor - Wet and dry gas.....	12
2.4	Handling and transport .....	13
2.5	Pump storage and draining procedure.....	14
<b>3</b>	<b>Design of a system .....</b>	<b>15</b>
3.1	System layout (Zone 1/1) .....	15
3.2	Liquid separator.....	16
3.3	Cavitation .....	16
3.4	Service liquid requirement.....	17
3.5	Pipe system.....	18
3.6	Suction filter .....	18
<b>4</b>	<b>Installation and start-up.....</b>	<b>19</b>
4.1	Securing the pump.....	19
4.2	Connections to the pump.....	19
4.3	Connecting the service liquid .....	20
4.4	Transmission .....	20
4.5	Earth connection requirements.....	21
4.6	Prior to start-up.....	22
4.7	Direction of rotation .....	22

---

<b>5</b>	<b>Service, operation, maintenance and inspection intervals.....</b>	<b>23</b>
5.1	Inspection of bearings.....	23
5.2	Inspecting for leakage.....	23
5.3	Draining the liquid separator.....	24
5.4	Check grease cartridges (Category 2 pumps with grease cartridges).....	24
5.5	Lubrication of bearings (Category 2 pumps without grease cartridges).....	24
5.6	Inspection of ATEX safety device .....	25
5.7	Inspection and cleaning of service liquid's supply pipe.....	25
5.8	Calibration of ATEX safety device .....	25
5.9	Overhaul of pump .....	25
5.10	Inspection and cleaning of internal channels .....	26
5.11	Winterization.....	26
<b>6</b>	<b>Troubleshooting .....</b>	<b>27</b>
<b>7</b>	<b>Spare parts and tools.....</b>	<b>28</b>
7.1	Marking and identification.....	28
7.2	How to order.....	29
7.3	Spare parts.....	30
7.4	Gasket set.....	34
7.5	Special tool set.....	35

# 1 INTRODUCTION

## 1.1 Declaration of conformity

**SAMSON PUMPS**

### Declaration of Conformity

Annex IIA

**Samson Pumps A/S**

Petersmindevej 21  
DK-8800 Viborg

Hereby declares that the following products:

**Liquid ring pumps**

**TM3400, TM2500, TM1700, TM1600, TM600, TM350, SLP2100, SLP2700, SLP3100  
OM1000, OM700, OM500, OM450, OM250**

Conforms to the following directives:

**Machinery Directive 2006/42/EC**

**ATEX Directive 2014/34/EU**

Explosion protection as follows on nameplate:

 II 2G Ex h IIC T4 Gb Internal

 II 2G Ex h IIC T4 Gb External

I hereby declare, that the machine are in conformity with the following harmonized standards:

DS/EN ISO 12100:2011	Safety of machinery - General principles for design - Risk assessment and risk reduction
DS/EN 1012-2 + A1:2009	Compressors and Pumps - Safety requirements - Part 2: Vacuum pumps
DS/EN 1127-1:2011	Explosive atmospheres - Explosion prevention and protection - part 1: Basic concepts and methodology
DS/EN ISO 80079-36:2016	Explosive atmospheres - Part 36: Non-electrical equipment for explosive atmospheres - Basic method and requirements
DS/EN ISO 80079-37:2016	Explosive atmospheres - Part 37: Non-electrical equipment for explosive atmospheres - Non-electrical type of protection constructional safety "c", control of ignition sources "b", liquid immersion "k"

The standard above only applies to the extent that it is relevant for the purpose of the pump. The product must not be used before the complete system, which it must be incorporated in, has been conformity assessed and found to comply with all relevant health and safety requirements of 2006/42/EC and other relevant directives. The product must be included in the overall risk assessment.

ATEX Conformity Certificate Number **ExVeritas 19 ATEX 0582**

Viborg, 28.04.2020



Jan S. Christiansen – Manager, Technical dept.

DOC4047F

E-Mail | [info@samson-pumps.com](mailto:info@samson-pumps.com) | Samson Pumps A/S | Petersmindevej 21  
Web | [www.samson-pumps.com](http://www.samson-pumps.com) | Phone | +45 87 50 95 70 | DK-8800 Viborg

---

## 1.2 Explanation of warning symbols

Important technical and safety instructions are shown by symbols. If the instructions are not performed correctly, it can lead to personnel injuries or incorrect function of the pump.



To be used with all safety instructions that must be followed. A failure to follow the instructions may result in injuries and/or incorrect machine operation



This symbol stands for safety instructions which – if they are not observed – may lead to a risk of explosion. You must therefore always follow these instructions.

## 1.3 Disposal

Samson's liquid ring pump is manufactured so that most of the device can be reused/recycled.

Samson Pumps offer users of the company's pumps the option of returning used pumps to be restored or scrapped.

Alternatively, the pump must be taken apart and sorted into its separate components, by the customer (see section 7 for the pump's material).

These components must be disposed of in accordance with national regulations.

---

## 1.4 ATEX Directive 2014/34/EU

The pump may be incorporated into a larger system, if the internal atmosphere has an area classification of:  
Zone 1 (for ATEX category 2 pumps)

These pumps are certified in accordance with the ATEX Directive 2014/34/EU

For the certification to be valid, the pump must be installed as described in this manual.



II 2G Ex h IIC T4 Gb X Internal

II 2G Ex h IIC T4 Gb X External

ExVeritas 19 ATEX 0452X

Explanation of symbols and characters used in ATEX marking:



The European Commission's mark for Ex products

- II     Equipment group II (non-mining)
- 2     Equipment category
- G     Type of explosive atmosphere (G = Gas)
- Ex    Indication of equipment for use in potentially explosive atmospheres
- h     Explosion protection
- IIC    Gas group (explosion group)
- T4    Temperature class (T4 = 135°C)
- Gb    Equipment protection level

ExVeritas 19 ATEX 0452X is the certificate number.

- X     Special conditions for safe use only applies to Zone 0 liquid ring pumps.

---

## 1.5 Field of application



Inlet of foreign objects, including condensing gases can damage the pump



The pump is designed exclusively to pump gases, including atmospheric air



**WARNING!**  
Do not operate the pump so that cavitation can occur! For further information see instruction manual for the Samson Pumps vacuum limiter

It must be ensured that the inlet gas cannot react with the service liquid and create aggressive bonds that break down the pump's components.

For other operating data, see specifications.

- The pump may only be used with media that are not aggressive to the pump's materials. See section 7.3 for components and appertaining materials.
- When using ATEX-approved pumps, refer to the marking on the pump and the areas of application specified in the ATEX Directive.

# 2 TECHNICAL DATA

## 2.1 Dimensions

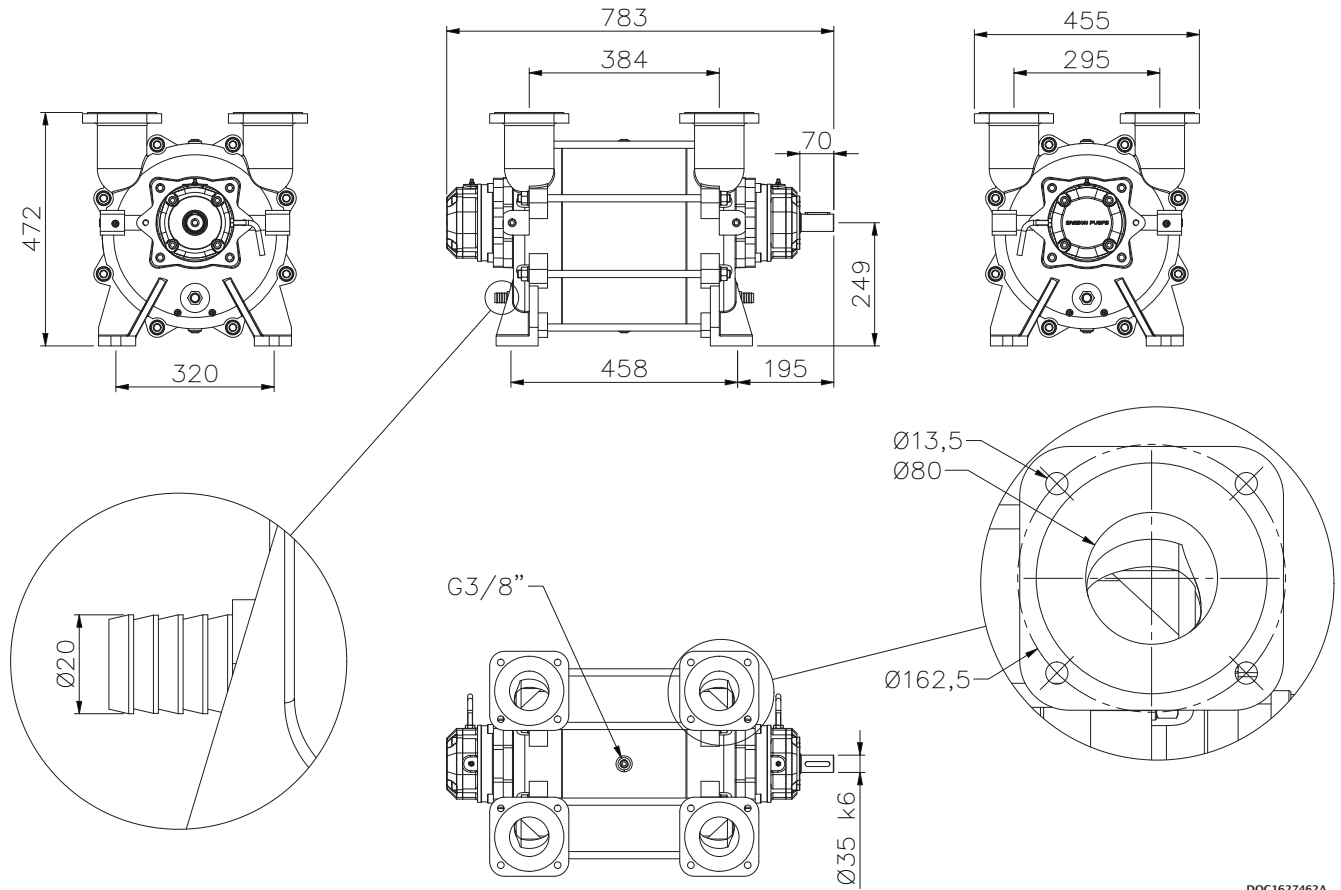

DOC1627462A



## 2.2 Specifications



A failure to meet these specifications may result in damage to the pump and a potential risk of explosion

Description		Minimum	Maximum
Ambient temperature, operation	Below 0°C – see chapter 5.3	-20°C	55°C
Ambient temperature, storage		-20°C	55°C
Humidity		-	100%
Intake temperature, suction side		-	60°C
Intake temperature, service liquid		-	60°C
Service liquid pipe connection, dimension		¾"	-
Service liquid pipe connection, length		-	6 m
For all connections, it is recommended to use the pump's existing connection size as minimum size.			
Noise level		-	80 dB(A)
Water volume		-	42 L
Maximum radial load on drive shaft		-	3900 N
Heat input for cooler calculation	0,85 x motor power consumption [kW]		
Revolutions		800 rpm	1800 rpm
Pressure		150 mbar abs.	2,5 bar(g)
Lubricating grease	Type of grease	SKF LGWA2	
	Automatic lubrication*	SKF LAGD 125/WA2	
Weight	Without branch pipes	217 kg	
	With branch pipes	242 kg	

It is required to install liquid separator to ensure the pump is supplied as much water as needed. See System layout Zone 1/1.

\* -Automatic lubrication: Zone 1/1 – Optional.

## 2.3 Power consumption and output

### 2.3.1 Performance

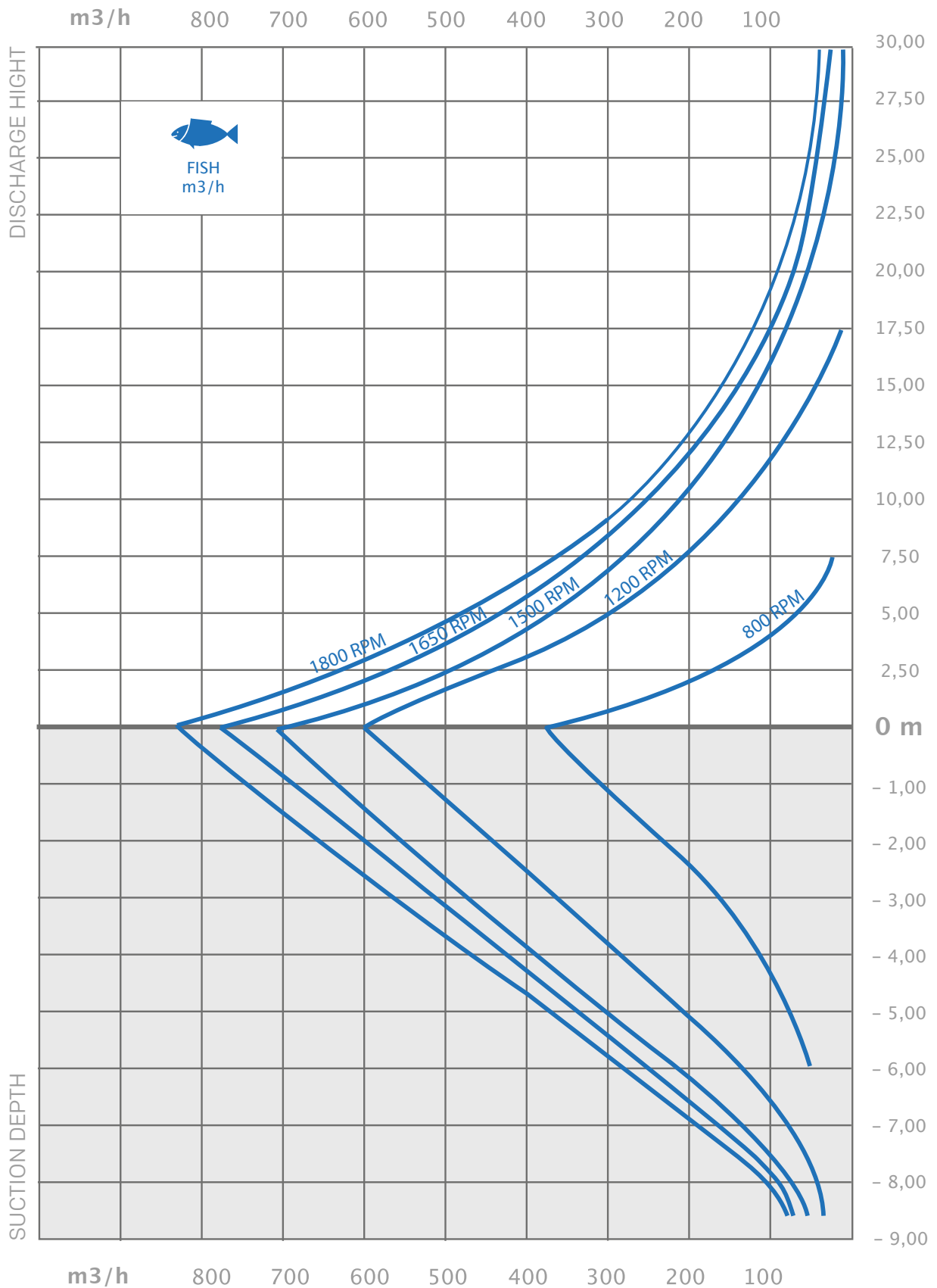

DOC11583B

### 2.3.2 Consumption

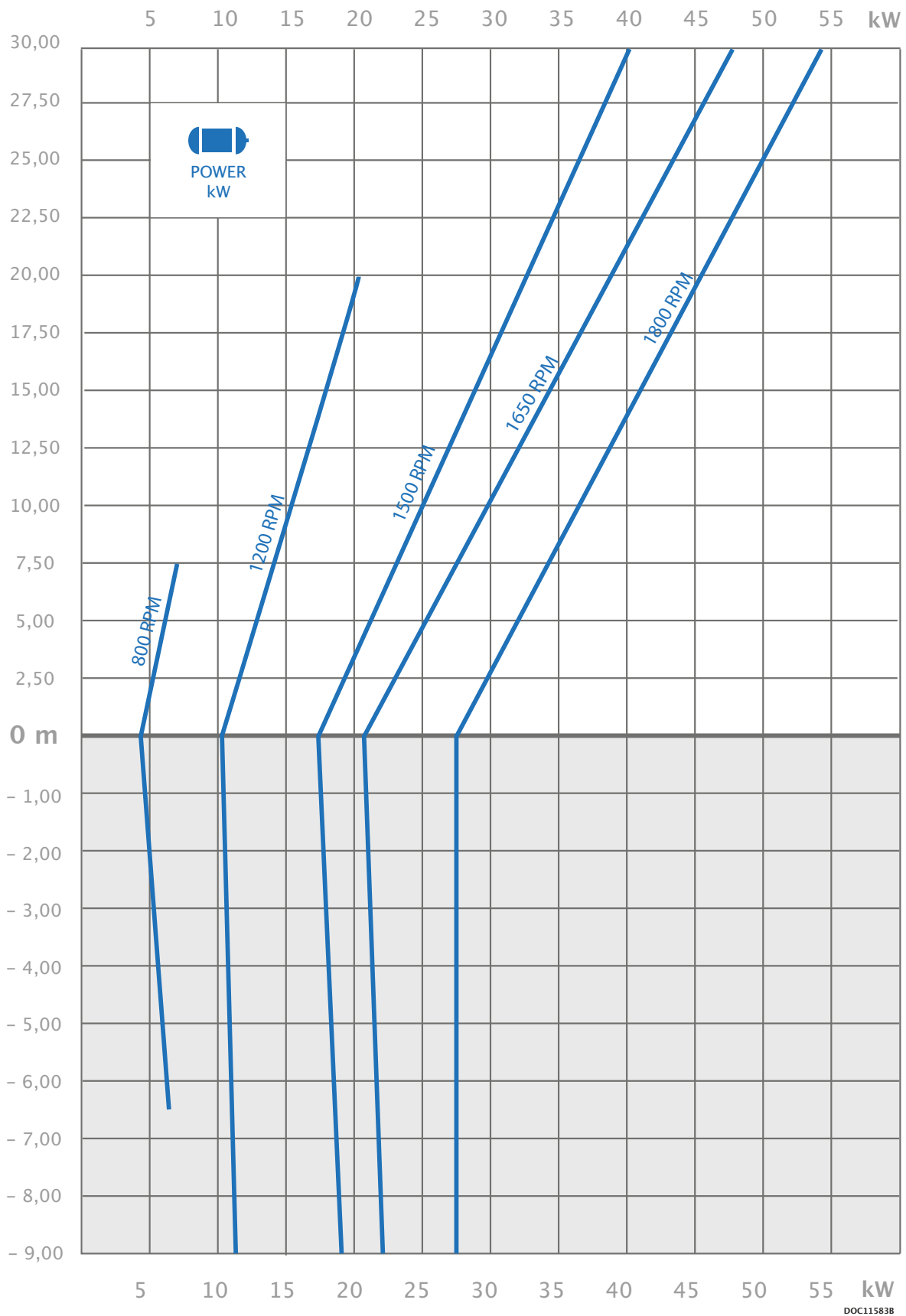

### 2.3.3 Correction factor – Temperature



Suction pressure and service liquid temperature to be adjusted in such way that cavitation cannot occur

When the temperature of the service liquid exceeds 15°C, the pump's capacity will be affected with respect to the specified values.

To determine the output at a higher temperature, the correction factor can be used.

Capacity at service liquid temperature higher than 15°C :

$$Q_{t>15} = Q_{15} \times K_1$$

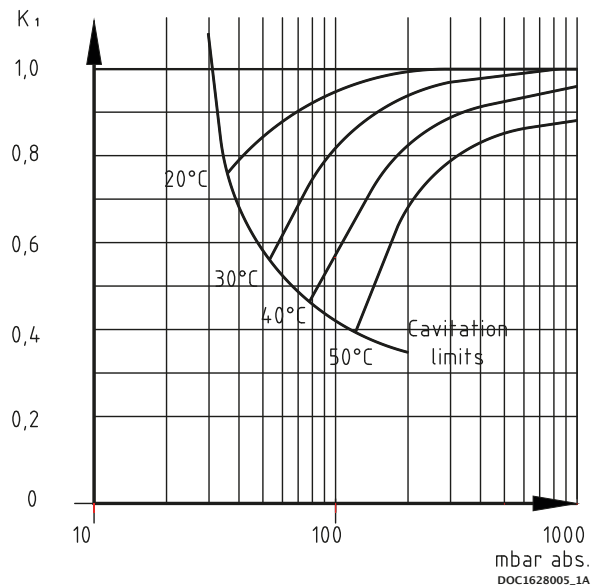

### 2.3.4 Correction factor – Wet and dry gas

Normal atmospheric air contains water vapor. In this case water will condense inside the pump and will create a higher flow.

Below you can find a correction factor table for the performance based on condensing gas with an inlet temperature of 50°C 100% saturated and service liquid temperature of 15°C.

Suction pressure % Vacuum	80	70	60	50	40	30	20
Correction factor wet gas $K_{Wet}$	1,34	1,28	1,15	1,13	1,09	1,08	1,07

The performance of the pump can thereby be calculated as:

$$V_{Wet} = V_{Dry} \times K_{Wet}$$

## 2.4 Handling and transport



The pump must not be used if it is damaged or the identification plate is missing  
ATEX marking must correspond to the area the pump is operating in

The pump must be transported in such way that it is not exposed to vibrations and impacts that can overload the bearings.

The pump must be inspected for damages upon delivery. If the pump is damaged, it must not be used and the damage must be reported to the manufacturer.

Ensure that the pump's identification plate is intact and that the marking of the pump corresponds to its use.

The pump must only be handled using approved lifting eyes, in accordance with nationally applicable regulations and only in a vertical motion.

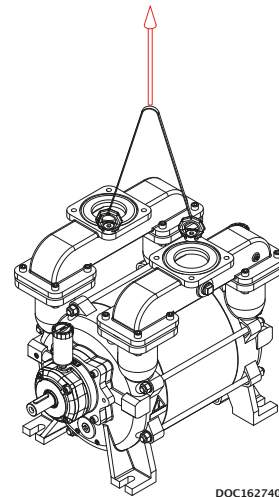

The pump can be transported in the following ways:

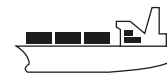

## 2.5 Pump storage and draining procedure



A failure to comply with the requirements for storing the pump may result in internal damage to the device



If the temperature is below freezing point of the service liquid, it could damage the pump. Under these conditions, the pump must be drained completely.



All plugs and protective covers must be fitted during storage.

The pump's service liquid is drained on delivery, and the pump can be immediately stored in accordance with the technical specifications.

After operation, the pump can be stored for 30 days without further action.

If the pump remains out of operation for a longer period of time after use, its service liquid must be drained, and the liquid supply to the pump must be shut off.

When emptying the pump, it is important that all chambers inside the pump are emptied.

The pump can be fitted with valves in the draining connections. See below.

After use with sea water it is recommended to drain and flush the pump with fresh water.

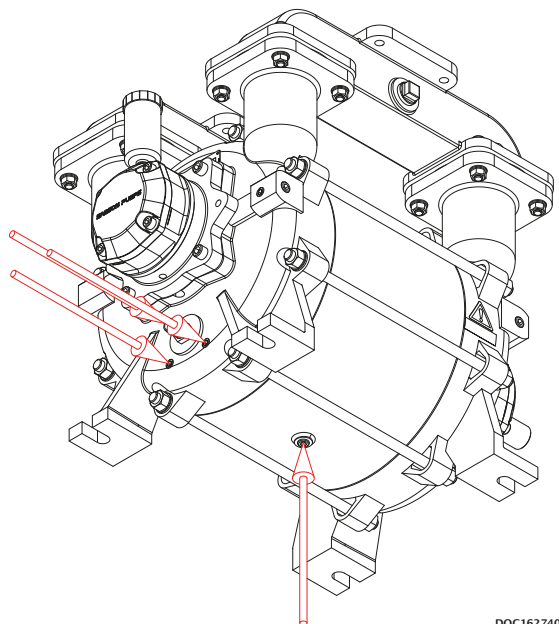
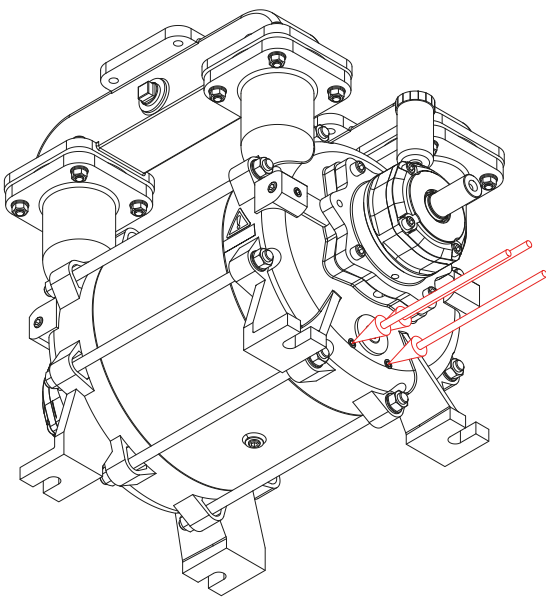

DOC1627404

# 3 DESIGN OF A SYSTEM

## 3.1 System layout (Zone 1/1)



Install an automatic service liquid supply, for example the shown float valve pos 5 - OR provide the liquid separator with an alarm for low level of service liquid pos 17



The maximum working pressure must not exceed specifications, by installing a safety valve

Systems in this category can be built as illustrated below:

Use an automatic stop valve pos 10, which opens the service liquid supply to the pump when it starts.

Select only 1 safety device (SD), pos. 5 or pos. 17

SIL requirement to safety function. Applies for safety device (SD).

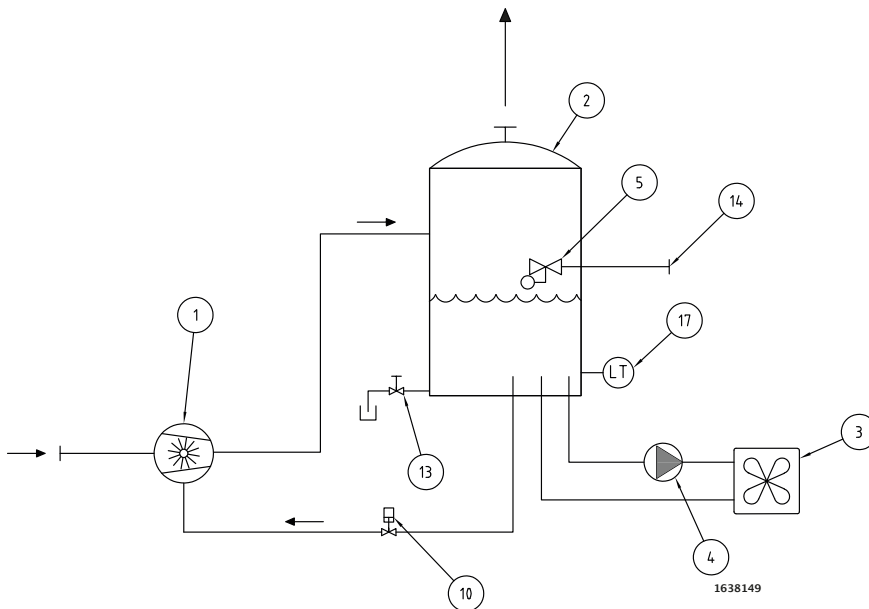

Pos.	Description
1	Vacuum pump
2	Liquid separator
3	Cooler
4	Circulation pump
5	Float valve SD
10	Stop valve
13	Drain valve
14	Service liquid connection
17	Level transmitter SD

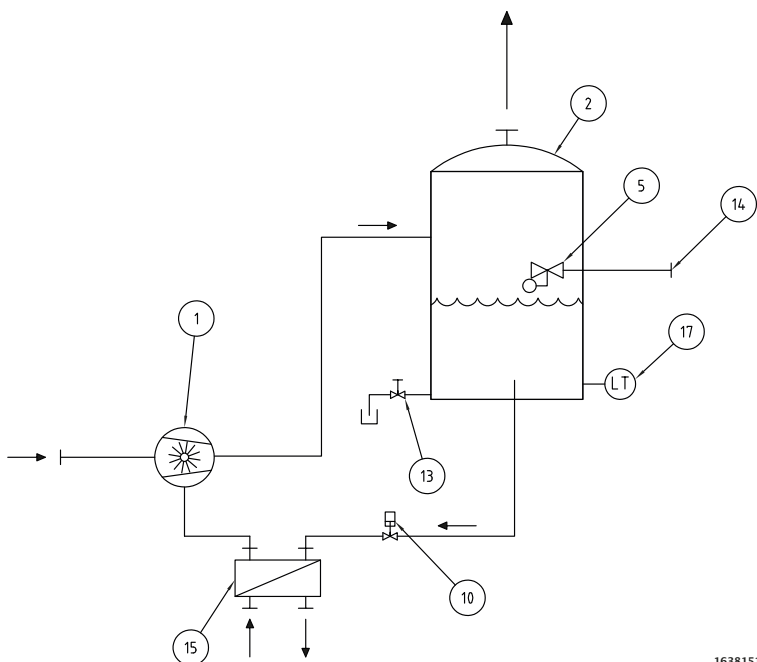

Pos.	Description
1	Vacuum pump
2	Liquid separator
5	Float valve SD
10	Stop valve
13	Drain valve
14	Service liquid connection
15	Plate heat exchanger
17	Level transmitter SD

## 3.2 Liquid separator



Liquid separator must be mounted in such way that the minimum level of service liquid is minimum 0,5 m above the pump's shaft



When operating the drain valves, the outlet may contain explosive gases, corresponding to the classification of the pump's suction side

The liquid separator must be located in immediate proximity to the pump, so that the length of the outlet pipe from the pump is minimised. Due to potential pressure loss, the length may not exceed 2 metres. The level of liquid in the liquid separator is recommended to be kept at 1–1.5 metres above the pump's shaft. This ensures the correct influx pressure and the correct flow of service liquid.

The liquid supply between the liquid separator and pump must be implemented with a permanent pipe connection with a dimension and length specified in specifications.

It may be advantageous to fit the liquid separator with a float valve which automatically supplies liquid and maintains a constant level.

The liquid separator can be fitted with a drain valve at the lowest place in the tank. The valve can be operated when the separator needs to be drained to remove contaminants.

## 3.3 Cavitation

When the temperature reaches the boiling point of the water, steam bobbles will be created in the liquid ring.

These bobbles cannot exist when they enter the discharge side of the pump and therefore they will collapse. The impact force on the surface of the rotor and flow plate will damage the pump and can lead to a total breakdown. It is a very harmful situation that must be avoided.

It is the combination of the pressure and the temperature that will lead to the cavitation. Therefore, it is recommended to install a cavitation valve, see illustration below that shows a clockwise rotating pump. If counter-clockwise rotating pump, mount in opposite branch pipe.

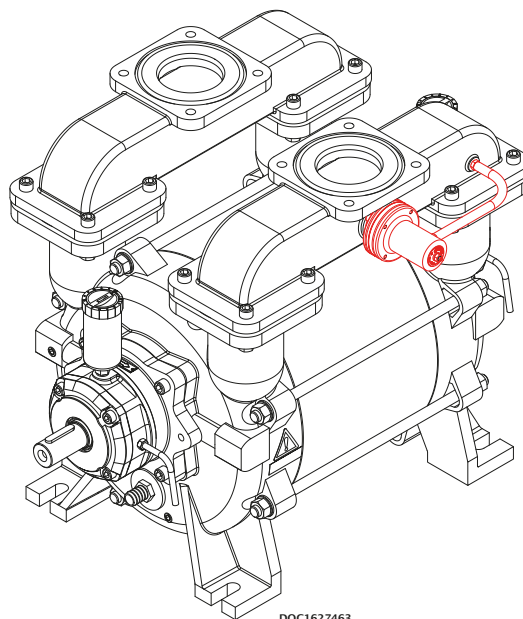

DOC1627463



---

Below you find the boiling point of water as a function of the pressure.

Vacuum	50%	75%	80%	90%
Temperature °C	80	64	59	44
Maximum discharge temperature	70	50	40	30

Note that the temperature of the gas inside the pump will heat up the water and the water surface therefore will become a higher temperature than the measured temperature on the discharge side of the pump. Cavitation will therefore start at a lower temperature and the maximum discharge temperature of the water must be kept lower.

### 3.4 Service liquid requirement

If sea water is used as sealing water, it is recommended to flush the pump with fresh water after use and drain the pump afterwards.

Before the pump is started again, remember to fill the pump to about shaft height before start up. Otherwise the pump will be started with dry run of the mechanical shaft seals, which will shorten the lifetime.

A drain valve mounted in the pump will help to identify the correct level of water. See below.

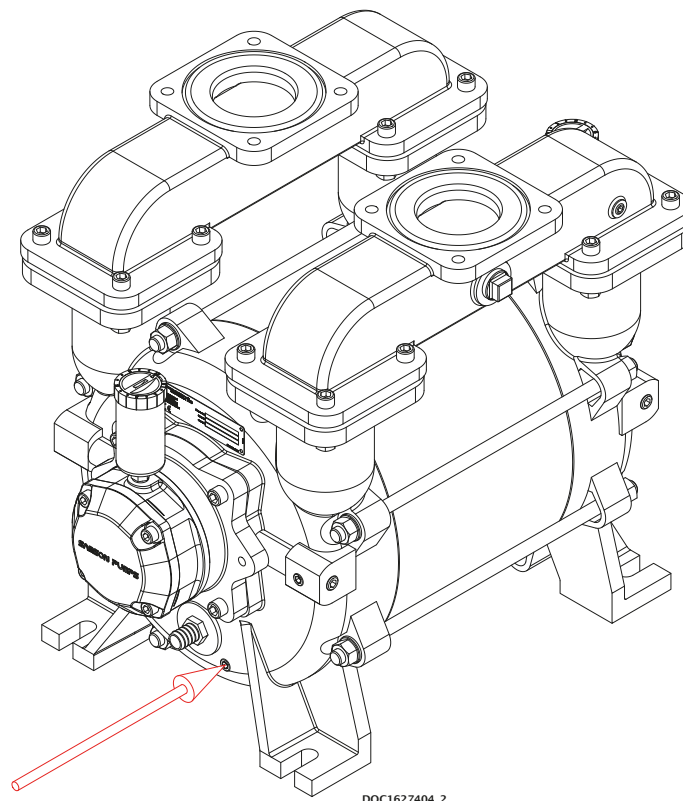

---

### 3.5 Pipe system



The exhaust from the liquid separator will have the same zone classification as the pump's suction side

The pipes that are connected to the pump's suction and outlet sides must be at least the same dimension as the pump. The length of the pipe system affects the pump's capacity and should be calculated to account for pressure drop in longer pipe installations.

Depending on the operating pressure, longer pipe lengths may affect the pump's output. For pipe lengths greater than 20 metres, a pressure drop calculation should be made, and the pipe dimensions should be increased so that the pressure loss is held to an acceptable level.

The pipe system should be mounted so that the horizontal pipes have a min. of 1% decline back towards the liquid separator.

Table below can be used for reference values.

Connection	Length < 20 metres	Length 20–50 metres	Length 50–100 metres
Suction side	Min. DN 100	Min. DN 125	Min. DN 150
Outlet side	Min. DN 100	Min. DN 125	Min. DN 150

The outlet from the liquid separator should be led outside of the building because the outlet air is warm and humid.

With respect to the exhaust, measures must be put in place to account for damp air that may form ice in cold surroundings.

### 3.6 Suction filter

In installations where there is a risk of sucking foreign elements into the pump, a filter must be mounted on the pump's suction side with a maximum mesh size of 2 mm.

# 4 INSTALLATION AND START-UP

## 4.1 Securing the pump



Installation requirements must be observed, otherwise there is a risk of damage and of potential explosion

The pump must be installed on a stable foundation, which must be level and stable, so that the pump is not twisted or exposed to a profile distortion.

The pump must be installed with M16 bolts on all four legs, which must be tightened to 180 Nm (A).

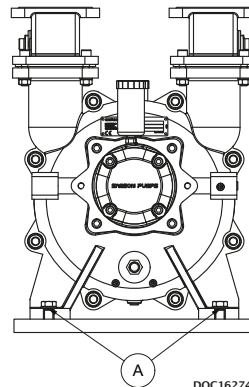
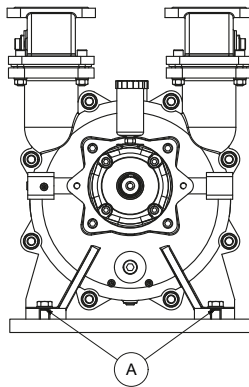

## 4.2 Connections to the pump



- Check for foreign objects in the pump and physical damage on pump
- Gaskets to be handled with highest degree of caution
- Gasket and sealing surfaces must be cleaned before assembly



External effects on the pump may lead to leakage and, as a result, a potential risk of explosion

Immediate before connecting the pipes, remove protective covers. Connection of the pump's suction and pressure pipe connections must be made with a gasket in between (C).

The M12 bolts must be tightened with 60 Nm (B).

In order to prevent tensions in the pump, the pipe connections (A) must be tensionless while tightening the bolts.

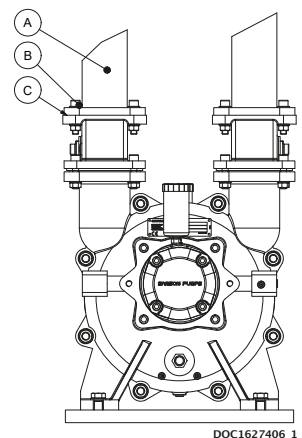

---

### 4.3 Connecting the service liquid

The service liquid must be connected to the pump at the hose connection, see illustration below.

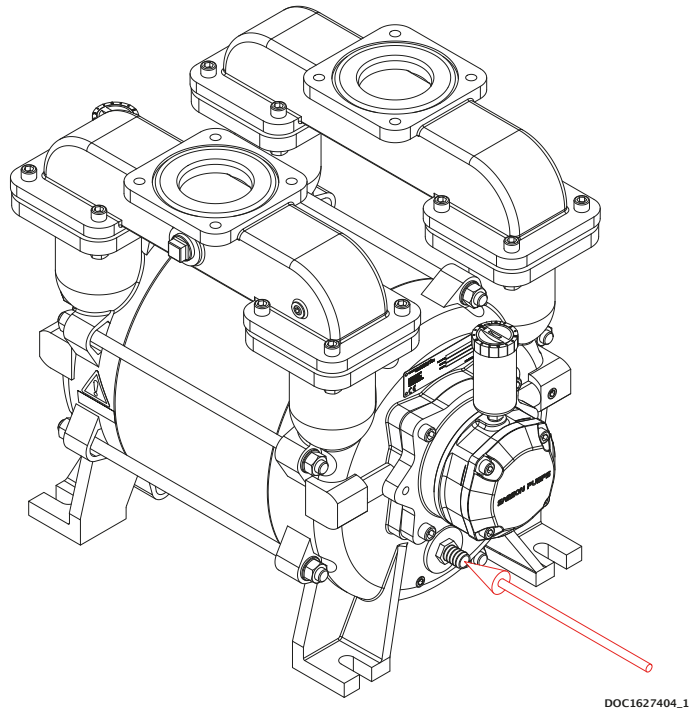

### 4.4 Transmission

The pump can be connected direct or through belt transmission. For belt transmission, it must be ensured that the permissible radial force is not exceeded. See specifications.

---

## 4.5 Earth connection requirements



The pump must be connected to earth to prevent static electricity. Static electricity is a potential source of ignition.

The pump must be protected from the creation of sparks in connection with static electricity, in accordance with the applicable regulations for use in the current categories.

The pump is prepared for earth connection with an M8 bolt.

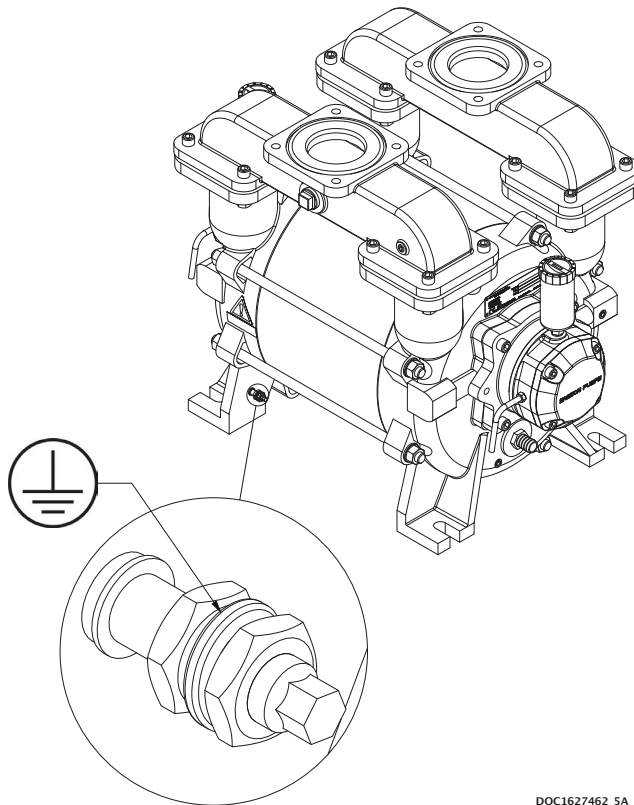

DOC1627462\_SA

## 4.6 Prior to start-up



- Do not start the pump without service liquid, as this will damage the mechanical shaft seals
- Do not start the pump if it is completely filled with service liquid
- Do not start the pump before the grease cartridges have been activated, as this can damage the pump (if equipped)
- Stop the pump immediately if the rotational direction does not correspond to the directional arrow
- A failure to follow the above guidelines may result in damage to the pump

### Activating the grease cartridges (Accessories)

Turn the handle in NDE clockwise to position 12.  
Turn the handle in DE clockwise to position 12.  
The pump has been lubricated from factory and is ready to start.



DOC3707

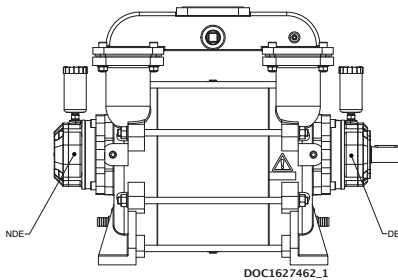

DOC1627462\_1

## 4.7 Direction of rotation

Check the direction of rotation by briefly starting the pump.

The direction of rotation of the rotor must correspond to the direction arrow!

Below left, a right-side pump is shown which has a clockwise direction of rotation (CW)

Below right, a left-side pump is shown which has a counter-clockwise direction of rotation (CCW)

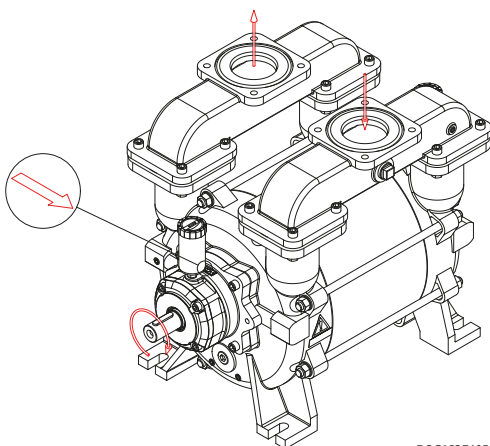

DOC1627405

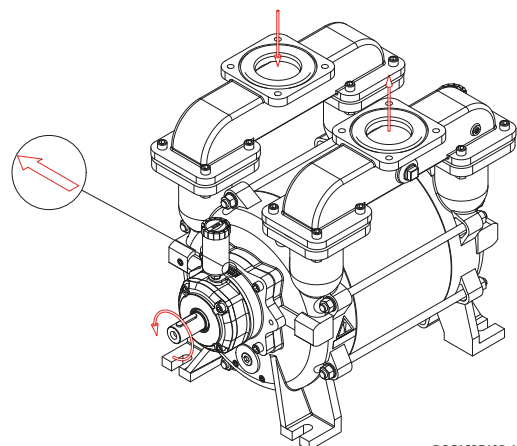

DOC1627405\_1

# 5 SERVICE, OPERATION, MAINTENANCE AND INSPECTION INTERVALS



A failure to observe the inspection intervals described in table below may result in damage to the pump and a potential risk of explosion

Section	Operation	Interval
5.1	Inspection of bearings	Weekly
5.2	Visually inspect for leakage	Weekly
5.3	Drain liquid separator to remove contaminants	Weekly
5.4	Check grease cartridges (if equipped)	Weekly
5.5	Lubrication of bearings	Per 500 duty hours
5.6	Inspection of ATEX safety device	Monthly
5.7	Inspection and cleaning (if necessary) of service liquid's supply pipe	Monthly
5.8	Calibration of ATEX safety device	Annually
5.9	Overhaul of pump	10,000 duty hours
5.10	Inspection and cleaning of internal channels	Monthly
5.11	Winterization	When below 0°C
6	Troubleshooting	As required

## 5.1 Inspection of bearings

The bearings of pump must be inspected once a day.

Be alert of unfamiliar sounds from bearing.

The measurements are performed after MIN. 30 min. of operation.

If operation time is less than 30 min., perform the measurements immediately after longest period of operation.

Temperature of bearings must not exceed the permitted temperature described in system layout.

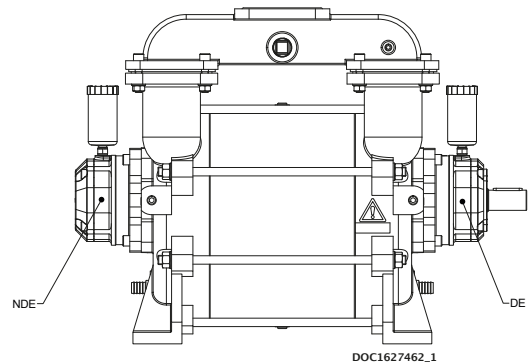

Pump	OM 700
Drive end (DE)	88°C
Non drive end (NDE)	88°C

## 5.2 Inspecting for leakage

The pump and pipe system around the pump must be inspected for leakage once a week. The inspection must be performed when the pump is both operating and idle. Any leaks must be repaired before operation may continue.

### 5.3 Draining the liquid separator

While the pump is stopped, the liquid separator must be drained to remove contaminants.

### 5.4 Check grease cartridges (Category 2 pumps with grease cartridges)



To prevent electrostatic discharge in hazardous areas, only wet cleaning is permitted  
Appropriate measures must be taken to prevent electric discharge

If the pump is equipped with an automatic lubrication feature. It must be inspected and replaced as needed.

When the pump is commissioned for the first time, the cartridges must be activated by turning the arrow in the clockwise direction.

The cartridge is set to 12, which corresponds to an emptying time of 12 months.  
The cartridge must be replaced when empty.



DOC3707

It is only allowed to use automatic lubricator of type **LAGD 125/WA2**.

### 5.5 Lubrication of bearings (Category 2 pumps without grease cartridges)



Over-lubrication of bearings may result in bearing damage! Do NOT exceed the amount of grease specified below!

The bearings must be lubricated with grease of type SKF LGWA2, per 500 duty hours.  
It is recommended to lubricate the bearings while pump is running.

#### Lubrication interval per 500 duty hours

Drive end (DE)	9 g
Non drive end (NDE)	9 g

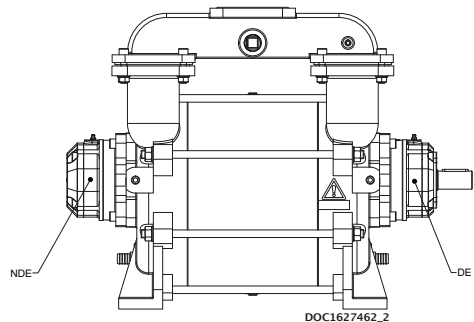

DOC1627462.2



---

## 5.6 Inspection of ATEX safety device



ATEX safety device must be inspected in accordance with table to ensure proper functionality. A failure to perform the required inspections will result in the discontinuation of the pump's approval

Safety devices to be inspected in accordance with applicable regulations.  
The components that make up the safety device can be found in the system layout.  
Float valve must be cleaned.

## 5.7 Inspection and cleaning of service liquid's supply pipe

The pipe connection between the liquid separator and pump must be inspected at least once a month, and any contaminants must be removed.

## 5.8 Calibration of ATEX safety device

Level transmitter (if equipped) must be calibrated once a year in accordance with the applicable requirements.  
The pump may not be started before the instruments have been re-installed.

## 5.9 Overhaul of pump

The pump must be serviced after 10,000 duty hours. This is done by sending the pump to Samson Pumps, or approved and certified partner, upon agreement. The pump must be cleaned before shipment.

Repairs carried out on ATEX pumps may only be performed by Samson Pumps, or approved and certified partner. If this requirement is not observed, and the pump's seal is broken, the pump's declaration of conformity is not valid and Samson Pumps is no longer responsible for any resulting consequences.

---

## 5.10 Inspection and cleaning of internal channels

The pump is designed with internal water channels for lubrication of the mechanical shaft seals. Remove the plug as illustrated below and clean the channel using a  $\varnothing 5$  mm 150 mm long screw driver or similar.

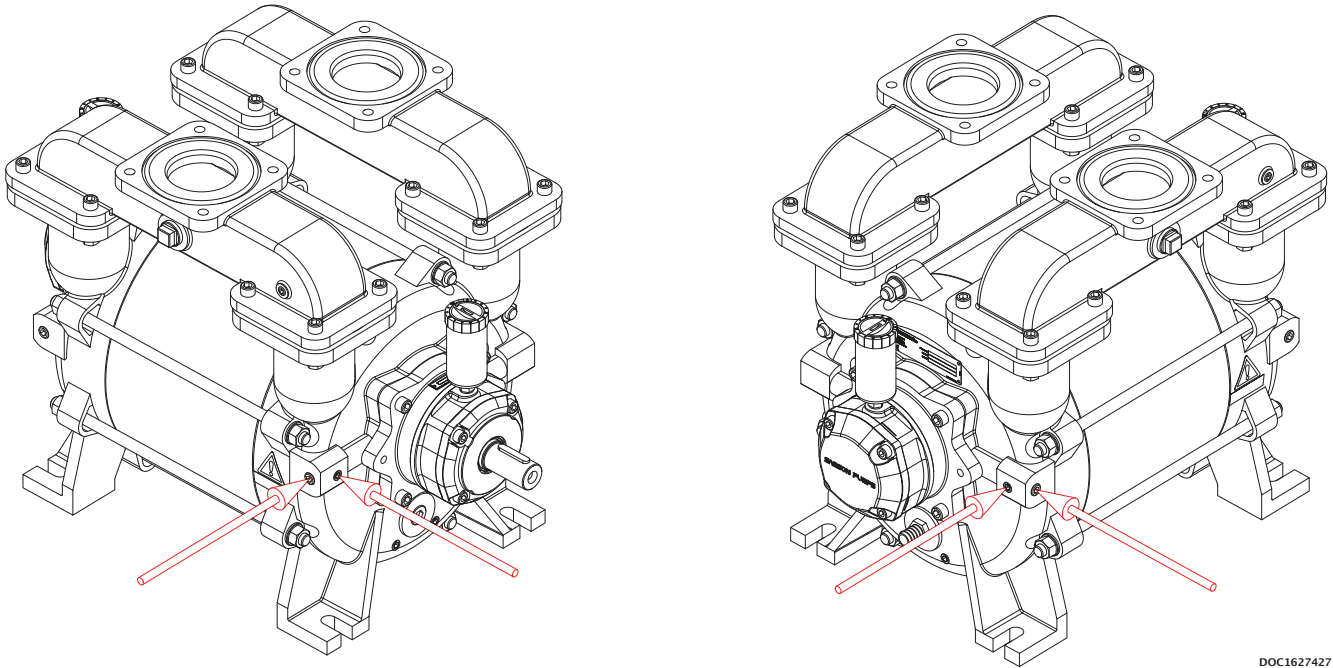

DOC1627427

## 5.11 Winterization

If the pump needs to be used at a temperature below freezing point of the service liquid, it is necessary to protect the liquid from freezing by adding anti freeze liquid.

# 6 TROUBLESHOOTING

Problem	Cause	Effect	Corrective measure
<b>The pump is unable to create a vacuum</b>	<ul style="list-style-type: none"> <li>• Service liquid valve is closed</li> <li>• The pump is not receiving enough service liquid</li> <li>• The temperature of the service liquid is too high</li> </ul>	<ul style="list-style-type: none"> <li>• Reduced output</li> <li>• The pump can become damaged during cavitation</li> </ul>	<ul style="list-style-type: none"> <li>• Check service liquid valve</li> <li>• Check the liquid supply</li> <li>• Stop the pump and wait until the temperature has dropped to a sufficient level, or lower the temperature of the service liquid inlet</li> </ul>
<b>The start-up power is too high</b>	<ul style="list-style-type: none"> <li>• Too much service liquid in the pump prior to start-up</li> </ul>	<ul style="list-style-type: none"> <li>• Noise at start-up and possible overload of the power supply</li> </ul>	<ul style="list-style-type: none"> <li>• Check the stop valves in the liquid supply for leakage</li> </ul>
<b>Noise during operation</b>	<ul style="list-style-type: none"> <li>• Cavitation</li> </ul>	<ul style="list-style-type: none"> <li>• Severe damage to the pump and potential risk of breakdown</li> </ul>	<ul style="list-style-type: none"> <li>• Increase the suction pressure or lower the temperature of the service liquid</li> </ul>
<b>Leakage from the bearing housing's drain holes</b>	<ul style="list-style-type: none"> <li>• Damaged shaft seal</li> </ul>	<ul style="list-style-type: none"> <li>• Bearings may become damaged</li> <li>• Potential risk of explosive gas leak</li> </ul>	<ul style="list-style-type: none"> <li>• Stop the pump and contact the manufacturer</li> </ul>

# 7 SPARE PARTS AND TOOLS

## 7.1 Marking and identification

The pump is equipped with an identification plate as shown below.

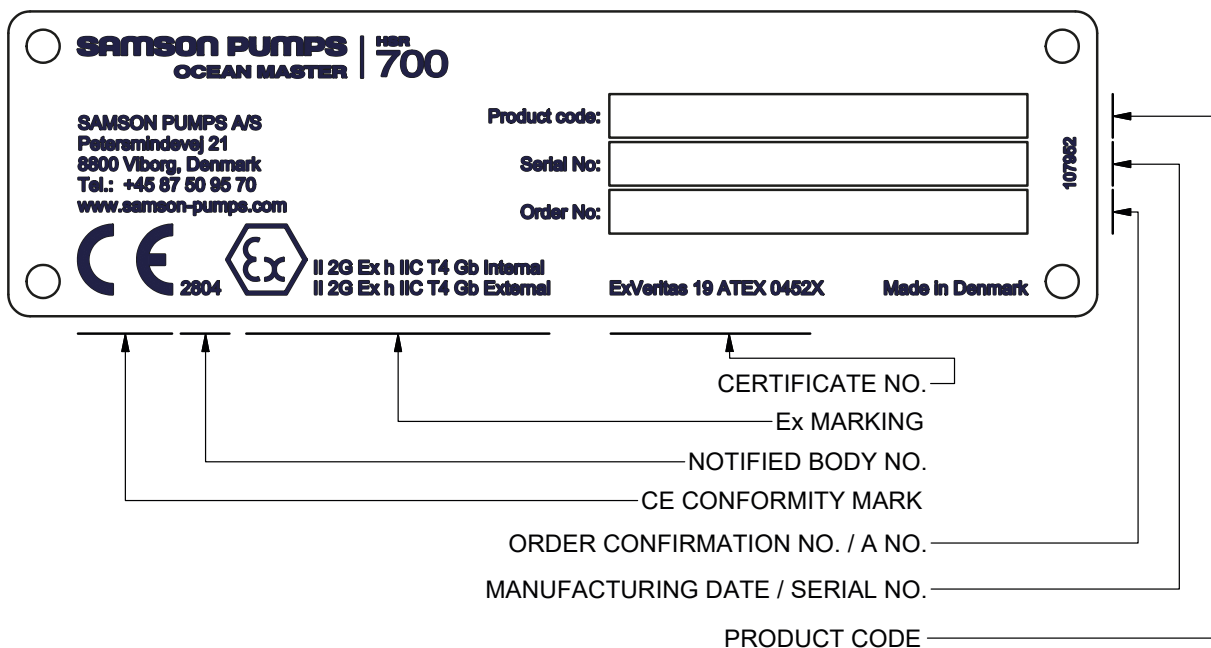

Configuration example:

**OM 700 R 0 S S B 1 0 S X1**

- Type: ←
- Model: ←
- Rotation: ←
- Rotor type: ←
- Pump housing: ←
- Shell: ←
- Flow plates: ←
- Generation of pump: ←
- Gaskets: ←
- Colour: ←
- Documentation: ←

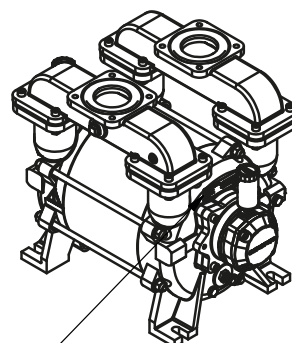

Location of ID plate

DOC107952C

## 7.2 How to order

Example:

OM 700 R 0 S S S 1 0 P X1

**Model:**

700 700

**Rotation:**

Clockwise R  
Counter clockwise L

**Rotor type:**

Welded AISI 316 0

**Pump housing:**

Cast iron EN-GJL-250; EN1561 S

**Shell:**

Cast iron EN-GJL-250; EN1561 S  
Stainless steel AISI 316 E

**Flow plates:**

Cast iron EN-GJL-250; EN1561 S  
Bronze GC-CU Sn10 DIN1705 B

**Generation of pump:**

1 or 2 1

**Gaskets:**

Oakenstrong 0

**Colour:**

Grey primer P  
Ocean Master Blue S  
On request X

**Documentation:**

Samson standard SD  
ATEX Zone 1 X1  
ATEX Zone 0 X5

### 7.3 Spare parts

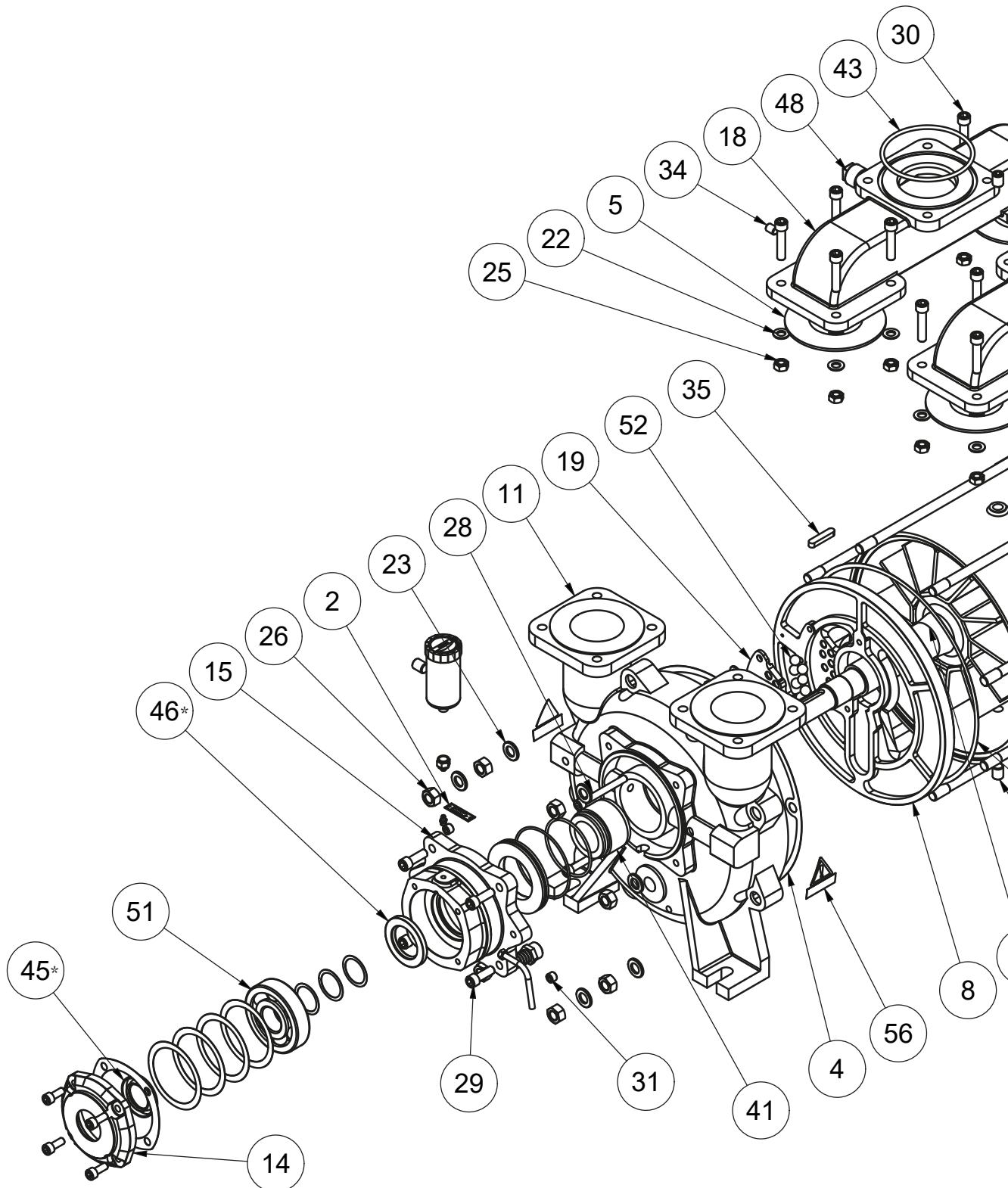

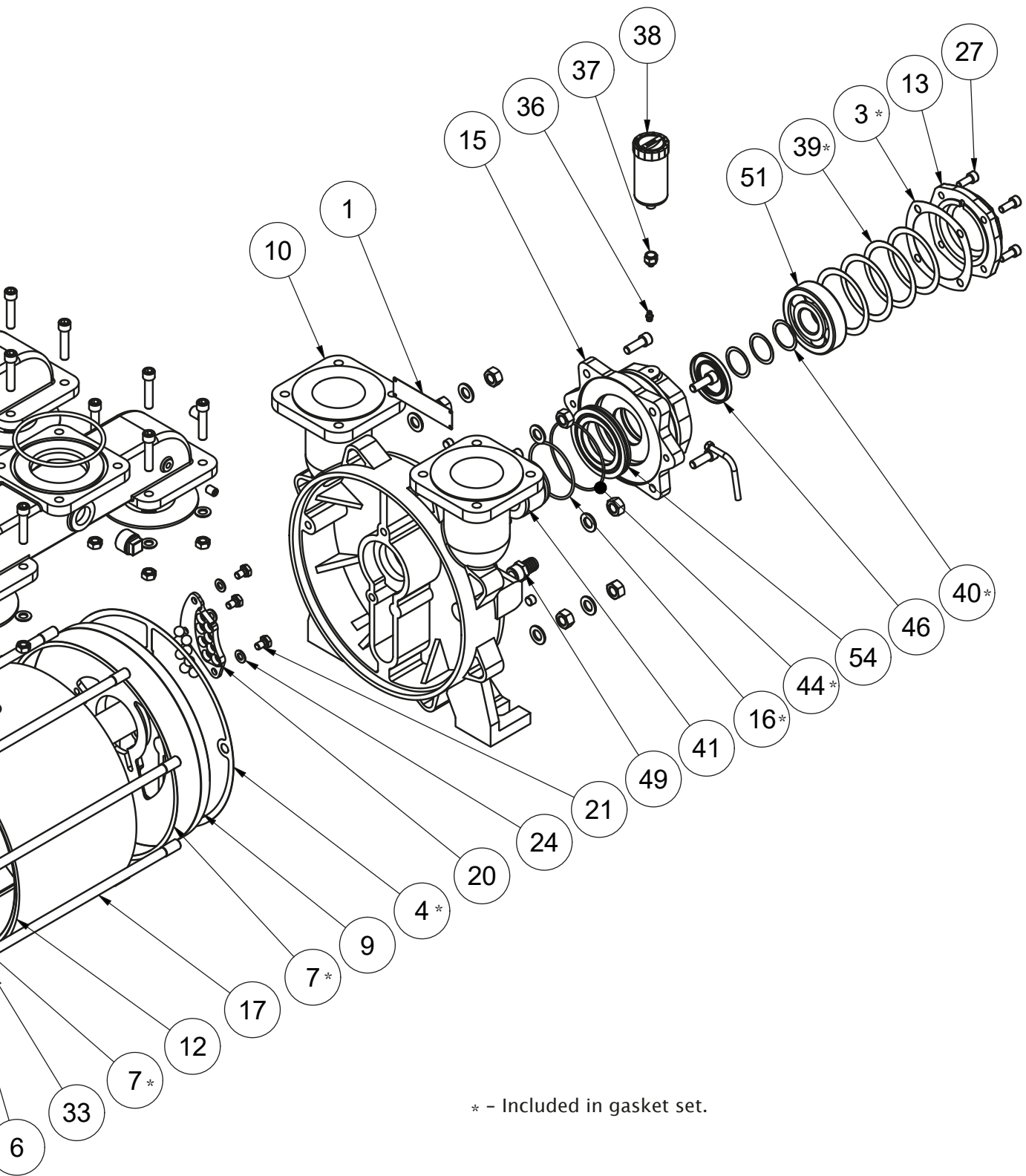

\* - Included in gasket set.

Pos.	Part number	Description	Qty.	Material
1	-	Identification plate	1	Stainless steel
2	-	Direction arrow	1	Aluminum
3	15053-P	Gasket set Ocean Master 700	1	-
4	15053-P	Gasket set Ocean Master 700	1	-
5	151.418	Gasket branch pipes	4	Rubber
6*	152.366	Rotor R	1	Stainless steel
	152.367	Rotor L	1	Stainless steel
7	15053-P	Gasket set Ocean Master 700	1	-
8*	157.320	Flow plate	1	Cast iron
	157.337	Flow plate	1	Bronze
9*	157.319	Flow plate	1	Cast iron
	157.338	Flow plate	1	Bronze
10	1619037	Pump housing NDE	1	Cast iron
11	1619038	Pump housing DE	1	Cast iron
12*	1619042	Shell	1	Cast iron
	1618074	Shell	1	Stainless steel
13	1619046	Bearing cover NDE	1	Cast iron
14	1619048	Bearing cover DE	1	Cast iron
15	1619199	Bearing housing	2	Cast iron
16	15053-P	Gasket set Ocean Master 700	1	-
17	1619059	Stay bolt	8	Steel
18	1619074	Branch pipe	2	Cast iron
19	1619150	Ball guide DE	1	Plastic
20	1619151	Ball guide NDE	1	Plastic
21	910000145	Screw	6	Stainless steel
22	910100016	Washer	16	Steel
23	910100022	Washer	16	Steel
24	910100135	Washer	6	Stainless steel
25	910200014	Nut	16	Steel
26	910200021	Nut	16	Steel
27	910300053	Allen screw	8	Steel
28	910300067	Allen screw	4	Steel
29	910300075	Allen screw	8	Steel
30	910300080	Allen screw	16	Steel
31	910300185	Plug	6	Steel
33	910300188	Plug	4	Steel
34	910300470	Plug	2	Stainless steel

\* -See section 7.1 for identification of pump.

\*\*-Optional. Not equipped as standard.



Pos.	Part number	Description	Qty.	Material
35	915000010	Parallel key	1	Steel
36	915000050	Grease nipple	2	Steel
37**	1634773	Nipple	2	Brass
38**	915000225	Automatic lubricator LAGD 125/WA2	2	Plastic / grease
39	15053-P	Gasket set Ocean Master 700	1	-
40	15053-P	Gasket set Ocean Master 700	1	-
41	922000039	Mechanical shaft seal	2	Steel
43	922100085	O-ring Ø134,30x5,70	2	Rubber
44	15053-P	Gasket set Ocean Master 700	1	-
45	15053-P	Gasket set Ocean Master 700	1	-
46	15053-P	Gasket set Ocean Master 700	1	-
48	925000136	Plug	4	Steel
49	925000240	Hose nipple	2	Brass
51	930000087	Ball bearing	2	Steel
52	962000046	Valve ball	16	Plastic
54	1619168	Insert for bearing housing	2	Stainless steel
56	1624020	Sticker Warning!	2	Plastic foil

\* -See section 7.1 for identification of pump.

\*\*-Optional. Not equipped as standard.

## 7.4 Gasket set



DOC11596

Pos.	Part number	Description	Qty.	Material
3	151.401	Gasket for bearing cover 0,4 mm	2	Paper
4	151.404	Gasket for pump housing / flow plate 0,4 mm	2	Paper
7	152.503	Gasket for shell / flow plate 0,5 mm	2	Paper
	1619101	Gasket for shell / flow plate 0,8 mm	2	Paper
	152.531	Gasket for shell / flow plate 1,0 mm	2	Paper
16	922100097	O-ring	2	Rubber
39	920000028	Shim 90x110x0,1	4	Steel
	920000029	Shim 90x110x0,2	4	Steel
	920000030	Shim 90x110x0,3	4	Steel
40	920000016	Shim 40x50x0.1	2	Steel
	920000193	Shim 40x50x0.3	2	Steel
	920000009	Shim 40x50x0.5	2	Steel
44	922100095	O-ring Ø88,49x3,53	2	Rubber
45	922200091	Radial shaft seal 40x65x10	1	Rubber / Steel
46	922200258	Radial shaft seal 50x80x8	2	Rubber / Steel

See spare parts drawing (DOC1627462\_3) for positions.

## 7.5 Special tool set

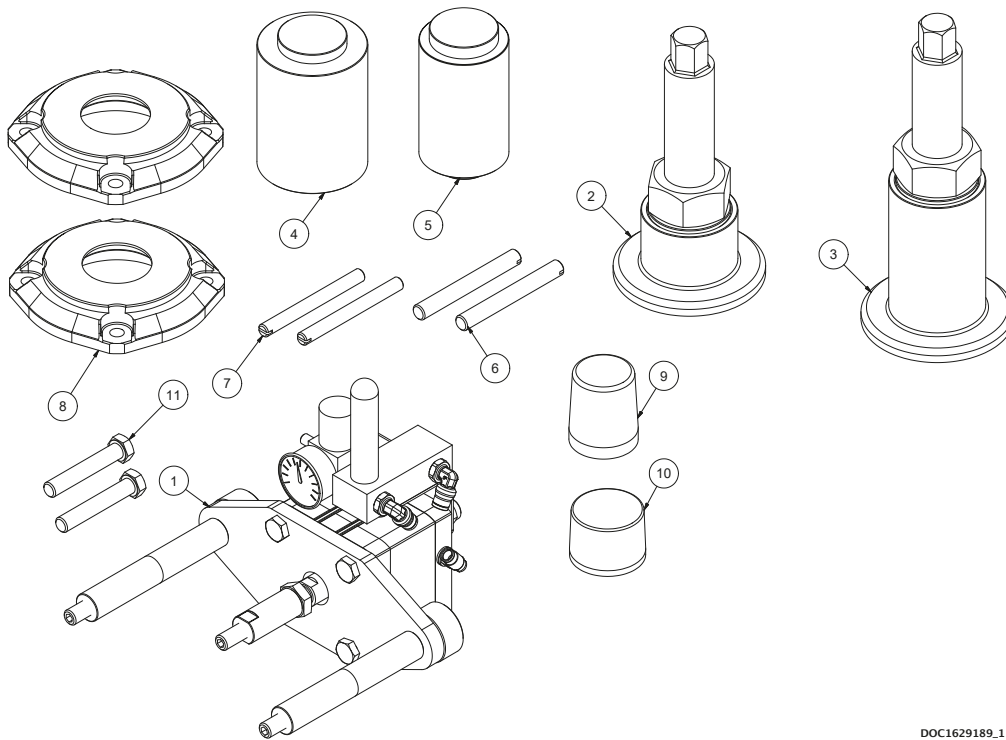

DOC1629189\_1

Pos.	Part number	Description	Qty.	Material
1	1629183	Bearing tool	1	Steel
2	1629107	Bearing mounting tool set NDE	1	Steel
3	1629108	Bearing mounting tool set DE	1	Steel
4	1629178	Mandrel radial shaft seal Ø50 + Ø55	1	Plastic
5	1629179	Mandrel radial shaft seal Ø40 + Ø50	1	Plastic
6	1629180	Guide pin M12	2	Steel
7	1629181	Guide pin M10	2	Steel
8	1629182	Machined bearing cap	2	Steel
9	1634151	Mounting sleeve for Ø50 mechanical shaft seal	1	Plastic
10	1634152	Mounting sleeve for Ø55 mechanical shaft seal	1	Plastic
11	910000366	M12x130 Set bolt	2	Steel









## **SAMSON PUMPS**

Samson Pumps is the only company in the world to specialise exclusively in liquid ring vacuum pumps. Samson pumps are made in Denmark and used around the globe. We offer worldwide delivery, and we export to more than 80 countries around the world.

For over 40 years, our name has been synonymous with the strongest pumps for vacuum trucks and tankers. We constantly adapt our products to meet the changing needs of our customers. Today, it is not enough to simply produce a pump. Products must be refined so the customer can concentrate on what they do best. We therefore offer a wide range of standardised components that allow our customers to build vacuum systems without the need for specialist in-house expertise.

Strength and durability are our hallmarks! We have often heard from customers that our pumps are working in many years, and in most cases without the need for maintenance or repair. This emboldens us to say that we have the strongest program of pumps on the market.