

INSTRUCTION MANUAL

LIQUID RING PUMP



SLP 2100/2700/3100

INSTRUCTION MANUAL FOR SAMSON LIQUID RING PUMPS
SLP 2100/2700/3100

-
- Technical data
 - Design of a system
 - Installation and start-up
 - Service
 - Troubleshooting
 - Spare parts

The English version of the instruction manual is the legally binding version.

CONTENTS

1	Introduction	4
1.1	Declaration of conformity.....	4
1.2	Explanation of warning symbols.....	5
1.3	Field of application.....	5
1.4	Disposal.....	5
2	Technical data.....	6
2.1	Dimensions.....	6
2.2	Specifications.....	7
2.3	Power consumption and output.....	8
2.3.1	Vacuum SLP2100	8
2.3.2	Pressure SLP2100.....	8
2.3.3	Vacuum SLP2700	9
2.3.4	Pressure SLP2700.....	9
2.3.5	Vacuum SLP3100	10
2.3.6	Pressure SLP3100.....	10
2.3.7	Correction factor – Temperature	11
2.3.8	Correction factor – Wet and dry gas.....	11
2.4	Handling and transport	12
2.5	Pump storage and draining procedure.....	13
3	Design of a system	14
3.1	Function and design of a liquid separator.....	15
3.2	Air cooling with fan cooler	16
3.3	Fan cooler	17
3.4	Water consumption	18
3.5	Dome valve system	18
3.6	Cavitation	19
3.7	Water requirement	19
4	Installation and start-up.....	20
4.1	Securing the pump.....	20
4.2	Connections to the pump.....	20
4.3	Connecting the water	21
4.4	Transmission	21
4.5	Prior to start-up.....	22
4.6	Direction of rotation	22

5 Service, operation, maintenance and inspection intervals..... 23

5.1 Draining the liquid separator and the pump 23

5.2 Check grease cartridges 23

5.3 Winterization..... 23

5.4 Lubrication of bearings 24

5.5 Inspection and cleaning of water supply pipe 24

5.6 Inspection and cleaning of internal channels 24

6 Troubleshooting25

7 Spare parts and tools.....26

7.1 Marking and identification..... 26

7.2 How to order..... 27

7.3 Spare parts – SLP..... 28

7.4 Spare parts – SL 32

7.5 Adaptor..... 36

7.6 Gasket set – SLP 37

7.7 Gasket set – SL..... 38

7.8 Bearing set – SL..... 39

7.9 Special tool set – SLP..... 40

1 INTRODUCTION

1.1 Declaration of conformity

SAMSON PUMPS

Declaration of Conformity

Annex IIA

Samson Pumps A/S
Petersmindevej 21
DK-8800 Viborg

Hereby declares that the following products:

Liquid ring pump
Truck Master 350, Truck Master 600, Truck Master 1600, Truck Master 1700, Truck
Master 2500, Truck Master 3400, SLP 2100, SLP 2700, SLP 3100

Conforms to the directive:

Machinery Directive 2006/42/EC

I hereby declare that the liquid ring pumps are in conformity with the following harmonized standards:

DS/EN ISO 12100:2011	Safety of machinery – General principles for design – Risk assessment and risk reduction
DS/EN 1012-2 + A1:2009	Compressors and Pumps – Safety requirements – Part 2: Vacuum pumps

The standards above only apply to the extent that it is relevant for the purpose of the pump. The product must not be used before the complete system, which it must be incorporated in, has been conformity assessed and found to comply with all relevant health and safety requirements of 2006/42/EC and other relevant directives. The product must be included in the overall risk assessment.

Viborg, 02.12.2020



Jan S. Christiansen – Manager, Technical dept.

DOC4044B

E-Mail info@samson-pumps.com	Samson Pumps A/S	Petersmindevej 21
Web www.samson-pumps.com	Phone +45 87 50 95 70	DK-8800 Viborg

1.2 Explanation of warning symbols

Important technical and safety instructions are shown by symbols. If the instructions are not performed correctly, it can lead to personnel injuries or incorrect function of the pump.



To be used with all safety instructions that must be followed. A failure to follow the instructions may result in injuries and/or incorrect machine operation

1.3 Field of application



Inlet of foreign objects can damage the pump



The pump is designed exclusively to pump gases, including atmospheric air



WARNING!
Avoid cavitation of the pump! For further information, see instruction manual for the Samson Pumps vacuum control valve (optional)

It must be ensured that the inlet gas cannot react with the water and create aggressive bonds that break down the pump's components.

For other operating data, see specifications.

- The pump must only be used with media that is not aggressive to the pump's materials. See section 7 for components and materials.

1.4 Disposal

Samson's liquid ring pump is manufactured so that most of the device can be reused/recycled.

Samson Pumps offer users of the company's pumps the option of returning used pumps to be restored or scrapped.

Alternatively, the pump must be taken apart and sorted into its separate components, by the customer (see section 7 for the pump's material).

These components must be disposed of in accordance with national regulations.

2 TECHNICAL DATA

2.1 Dimensions

SLP2100

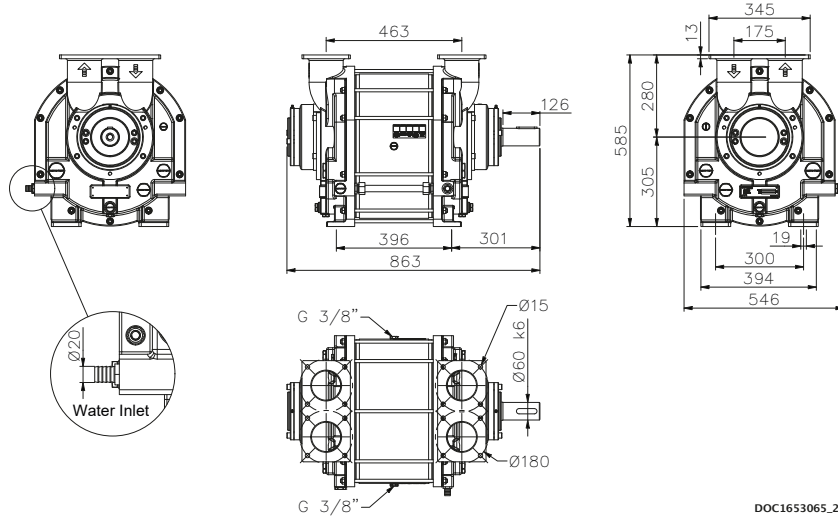

SLP2700

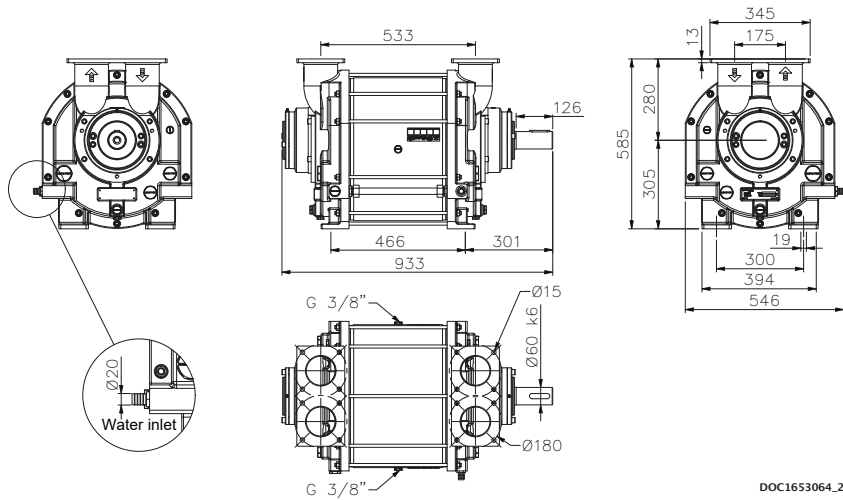

SLP3100

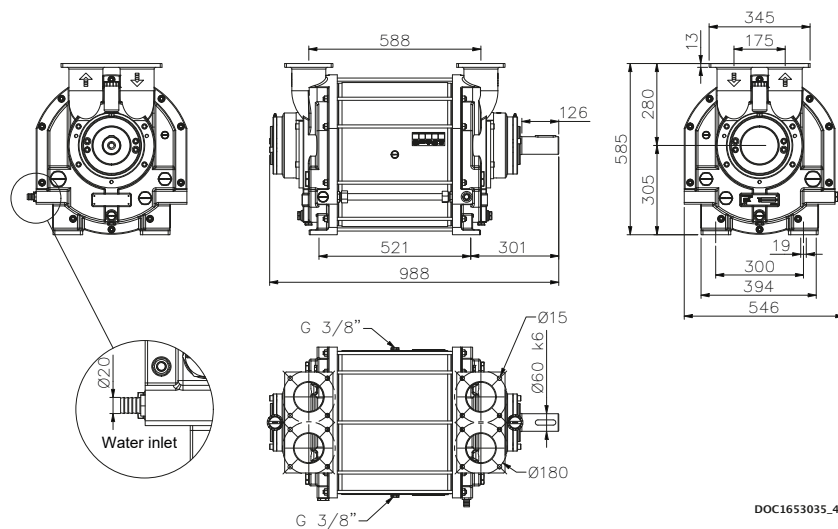

2.2 Specifications



A failure to meet these specifications may result in damage to the pump

Description		Minimum	Maximum	
Ambient temperature, operation	Below 0°C – see chapter 5.3	-20°C	55°C	
Ambient temperature, storage		-20°C	55°C	
Humidity		-	100%	
Intake temperature, suction side		-	60°C	
Intake temperature, water		-	60°C	
Water pipe connection, dimension		¾"	1"	
Water pipe connection, length		-	6 m	
Noise level		-	80 dB(A)	
Water volume	SLP 2100		55L / 20L	
	SLP 2700		64L / 24L	
	SLP 3100		71L / 28L	
Maximum radial load on drive shaft	SLP2100/2700/3100	-	15000 N	
Heat input for cooler calculation	SLP 2100	1200 rpm	30 kW	-
		1300 rpm	35 kW	-
		1400 rpm	40 kW	-
		1500 rpm	44 kW	-
		1600 rpm	51 kW	-
	SLP 2700	1200 rpm	35 kW	-
		1300 rpm	40 kW	-
		1400 rpm	45 kW	-
		1500 rpm	51 kW	-
		1600 rpm	59 kW	-
	SLP 3100	1200 rpm	42 kW	-
		1300 rpm	45 kW	-
		1400 rpm	51 kW	-
		1500 rpm	59 kW	-
		1600 rpm	68 kW	-
Revolutions		1200 rpm	1600 rpm	
Pressure		200 mbar abs.	1 bar(g)	
Lubricating grease	Type of grease	SKF LGWA2		
	Automatic lubrication	SKF LAGD 125/WA2		
Weight	SLP 2100	350 kg		
	SLP 2700	390 kg		
	SLP 3100	420 kg		

2.3 Power consumption and output

2.3.1 Vacuum SLP2100

Vacuum		[%]	80	70	60	50	40	30	20
1200 [rpm]	Flow _{Wet}	[m ³ /h]	1261	1411	1524	1700	1719	1750	1781
	Flow _{Dry}	[m ³ /h]	927	1102	1326	1505	1577	1620	1664
	Consumption	[kW]	40						
	Torque	[Nm]	318						
1300 [rpm]	Flow _{Wet}	[m ³ /h]	1373	1657	1684	1871	1881	1909	1949
	Flow _{Dry}	[m ³ /h]	1010	1295	1464	1656	1726	1768	1822
	Consumption	[kW]	46						
	Torque	[Nm]	338						
1400 [rpm]	Flow _{Wet}	[m ³ /h]	1689	1819	1794	1993	1995	2052	1661
	Flow _{Dry}	[m ³ /h]	1242	1421	1560	1763	1830	1900	1552
	Consumption	[kW]	53						
	Torque	[Nm]	362						
1500 [rpm]	Flow _{Wet}	[m ³ /h]	1822	2001	1958	2113	2141	2184	1915
	Flow _{Dry}	[m ³ /h]	1340	1563	1703	1870	1965	2022	1790
	Consumption	[kW]	59						
	Torque	[Nm]	376						
1600 [rpm]	Flow _{Wet}	[m ³ /h]	1930	2127	2104	2264	2270	2320	2022
	Flow _{Dry}	[m ³ /h]	1419	1662	1829	2003	2082	2148	1890
	Consumption	[kW]	68						
	Torque	[Nm]	406						

2.3.2 Pressure SLP2100

Pressure		[bar(g)]	0.5	1
1200 [rpm]	Flow	[m ³ /h]	1298	802
	Consumption	[kW]	45	46
	Torque	[Nm]	358	366
1300 [rpm]	Flow	[m ³ /h]	1358	1128
	Consumption	[kW]	53	55
	Torque	[Nm]	389	404
1400 [rpm]	Flow	[m ³ /h]	1452	1292
	Consumption	[kW]	60	65
	Torque	[Nm]	409	443
1500 [rpm]	Flow	[m ³ /h]	1582	1373
	Consumption	[kW]	67	77
	Torque	[Nm]	427	490
1600 [rpm]	Flow	[m ³ /h]	1674	1462
	Consumption	[kW]	77	88
	Torque	[Nm]	460	525

The data Flow_{Dry} is based on the following parameters:

- Air temperature 20°C
- Water temperature 15°C
- Test performed with dry air and 1,013 mbar absolute pressure
- Tolerance ±10%

2.3.3 Vacuum SLP2700

Vacuum		[%]	80	70	60	50	40	30	20
1200 [rpm]	Flow _{Wet}	[m ³ /h]	1641	1802	1553	2037	2092	2112	2096
	Flow _{Dry}	[m ³ /h]	1207	1408	1351	1803	1920	1956	1959
	Consumption	[kW]	46						
	Torque	[Nm]	366						
1300 [rpm]	Flow _{Wet}	[m ³ /h]	1795	2002	1837	2229	2260	2290	2035
	Flow _{Dry}	[m ³ /h]	1320	1564	1597	1972	2074	2121	1902
	Consumption	[kW]	53						
	Torque	[Nm]	389						
1400 [rpm]	Flow _{Wet}	[m ³ /h]	1837	2213	2054	2372	2440	2163	2203
	Flow _{Dry}	[m ³ /h]	1351	1729	1786	2099	2239	2003	2059
	Consumption	[kW]	60						
	Torque	[Nm]	409						
1500 [rpm]	Flow _{Wet}	[m ³ /h]	1970	2416	2218	2521	2556	2308	2308
	Flow _{Dry}	[m ³ /h]	1449	1888	1928	2231	2345	2137	2157
	Consumption	[kW]	68						
	Torque	[Nm]	433						
1600 [rpm]	Flow _{Wet}	[m ³ /h]	1987	2579	1553	2684	2707	2439	2440
	Flow _{Dry}	[m ³ /h]	1461	2015	1351	2375	2484	2258	2280
	Consumption	[kW]	78						
	Torque	[Nm]	466						

2.3.4 Pressure SLP2700

Pressure		[bar(g)]	0.5	1
1200 [rpm]	Flow	[m ³ /h]	1545	1034
	Consumption	[kW]	55	56
	Torque	[Nm]	438	446
1300 [rpm]	Flow	[m ³ /h]	1667	1191
	Consumption	[kW]	64	65
	Torque	[Nm]	470	478
1400 [rpm]	Flow	[m ³ /h]	1797	1407
	Consumption	[kW]	72	77
	Torque	[Nm]	491	525
1500 [rpm]	Flow	[m ³ /h]	1920	1525
	Consumption	[kW]	81	88
	Torque	[Nm]	516	560
1600 [rpm]	Flow	[m ³ /h]	2005	1635
	Consumption	[kW]	92	101
	Torque	[Nm]	549	603

The data Flow_{Dry} is based on the following parameters:

- Air temperature 20°C
- Water temperature 15°C
- Test performed with dry air and 1,013 mbar absolute pressure
- Tolerance ±10%

2.3.5 Vacuum SLP3100

	Vacuum	[%]	80	70	60	50	40	30	20
1200 [rpm]	Flow _{Wet}	[m ³ /h]	1685	1843	1658	2068	2158	2159	1838
	Flow _{Dry}	[m ³ /h]	1239	1440	1442	1830	1980	1999	1718
	Consumption	[kW]	56						
	Torque	[Nm]	446						
1300 [rpm]	Flow _{Wet}	[m ³ /h]	2012	2309	2072	2467	2542	2397	2248
	Flow _{Dry}	[m ³ /h]	1480	1804	1802	2184	2332	2220	2101
	Consumption	[kW]	60						
	Torque	[Nm]	441						
1400 [rpm]	Flow _{Wet}	[m ³ /h]	2100	2537	2248	2605	2724	2407	2361
	Flow _{Dry}	[m ³ /h]	1544	1982	1955	2306	2499	2229	2207
	Consumption	[kW]	68						
	Torque	[Nm]	464						
1500 [rpm]	Flow _{Wet}	[m ³ /h]	2162	2717	2503	2792	2860	2515	2555
	Flow _{Dry}	[m ³ /h]	1590	2123	2177	2471	2624	2329	2388
	Consumption	[kW]	78						
	Torque	[Nm]	497						
1600 [rpm]	Flow _{Wet}	[m ³ /h]	2298	2926	2732	2947	2638	2658	2658
	Flow _{Dry}	[m ³ /h]	1690	2286	2376	2608	2420	2461	2484
	Consumption	[kW]	90						
	Torque	[Nm]	537						

2.3.6 Pressure SLP3100

	Pressure	[bar(g)]	0.5	1
1200 [rpm]	Flow	[m ³ /h]	1703	1248
	Consumption	[kW]	64	65
	Torque	[Nm]	509	517
1300 [rpm]	Flow	[m ³ /h]	1897	1326
	Consumption	[kW]	72	75
	Torque	[Nm]	529	551
1400 [rpm]	Flow	[m ³ /h]	2001	1437
	Consumption	[kW]	81	86
	Torque	[Nm]	553	587
1500 [rpm]	Flow	[m ³ /h]	2143	1568
	Consumption	[kW]	93	99
	Torque	[Nm]	592	630
1600 [rpm]	Flow	[m ³ /h]	2279	1695
	Consumption	[kW]	106	116
	Torque	[Nm]	633	692

The data Flow_{Dry} is based on the following parameters:

- Air temperature 20°C
- Water temperature 15°C
- Test performed with dry air and 1,013 mbar absolute pressure
- Tolerance ±10%

2.3.7 Correction factor – Temperature

When the temperature of the water exceeds 15°C, the pump’s capacity will be affected with respect to the specified values.

To determine the output at a higher temperature, the correction factor can be used.

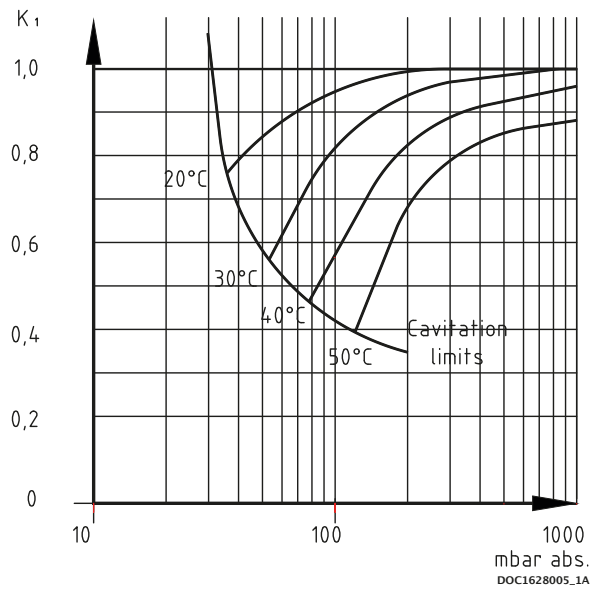

Capacity at water temperature higher than 15°C :

$$Q_{t>15} = Q_{15} \times K_1$$

2.3.8 Correction factor – Wet and dry gas

Normal atmospheric air contains water vapor. In this case water will condense inside the pump and will create a higher flow.

Below you can find a correction factor table for the performance based on condensing gas with an inlet temperature of 50°C 100% saturated and service liquid temperature of 15°C.

Suction pressure % Vacuum	80	70	60	50	40	30	20
Correction factor wet gas K_{Wet}	1,34	1,28	1,15	1,13	1,09	1,08	1,07

The performance of the pump can thereby be calculated as:

$$V_{Wet} = V_{Dry} \times K_{Wet}$$

2.4 Handling and transport



The pump must not be used if it is damaged or the identification plate is missing

The pump must be transported in such way that it is not exposed to vibrations and impacts that can overload the bearings.

The pump must be inspected for damages upon delivery. If the pump is damaged, it must not be used and the damage must be reported to the manufacturer.

Ensure that the pump's identification plate is intact and that the marking of the pump corresponds to its use.

The pump must only be handled using approved lifting eyes, in accordance with nationally applicable regulations and only in a vertical motion.

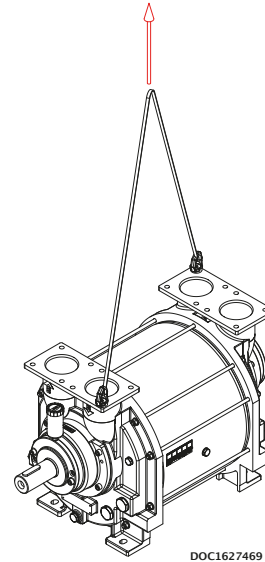

The pump can be transported in the following ways:

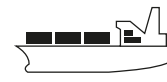

2.5 Pump storage and draining procedure



A failure to comply with the requirements for storing the pump may result in internal damage to the device



If the temperature is below freezing point of the service liquid, it could damage the pump. Under these conditions, the pump must be drained completely.



All plugs and protective covers must be fitted during storage.

The pump's water is drained on delivery, and the pump can be immediately stored in accordance with the technical specifications.

After operation, the pump can be stored for 30 days without further action.

If the pump remains out of operation for a longer period of time after use, its water must be drained.

Drain the pump in C₁ or C₂. The pump can be fitted with valves in the draining connections. See below.

Draining during normal operation, see chapter 5.

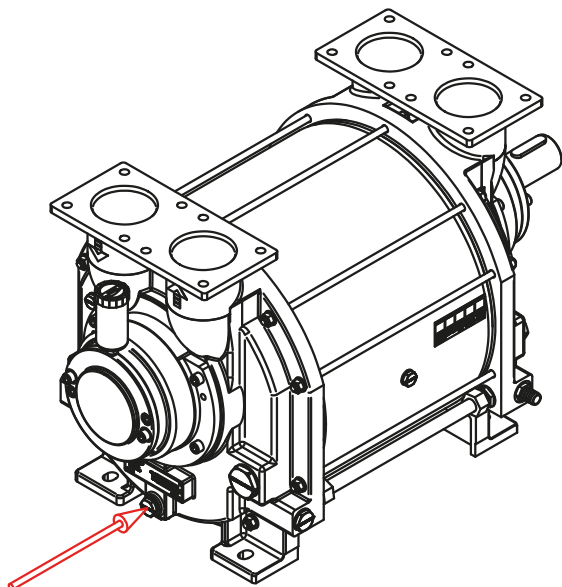

C1

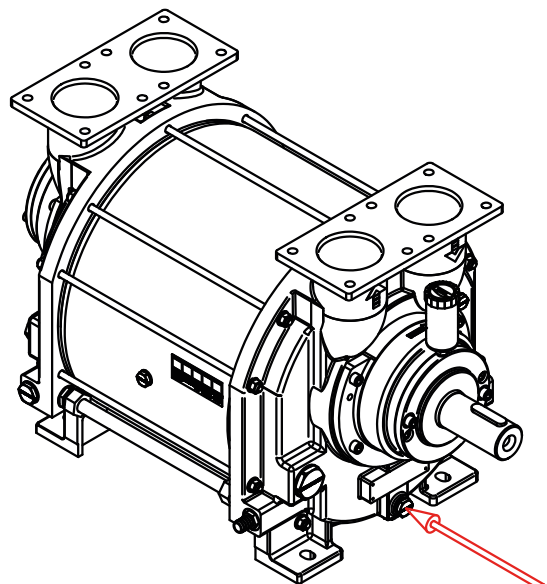

DOC16274708

C2

3 DESIGN OF A SYSTEM

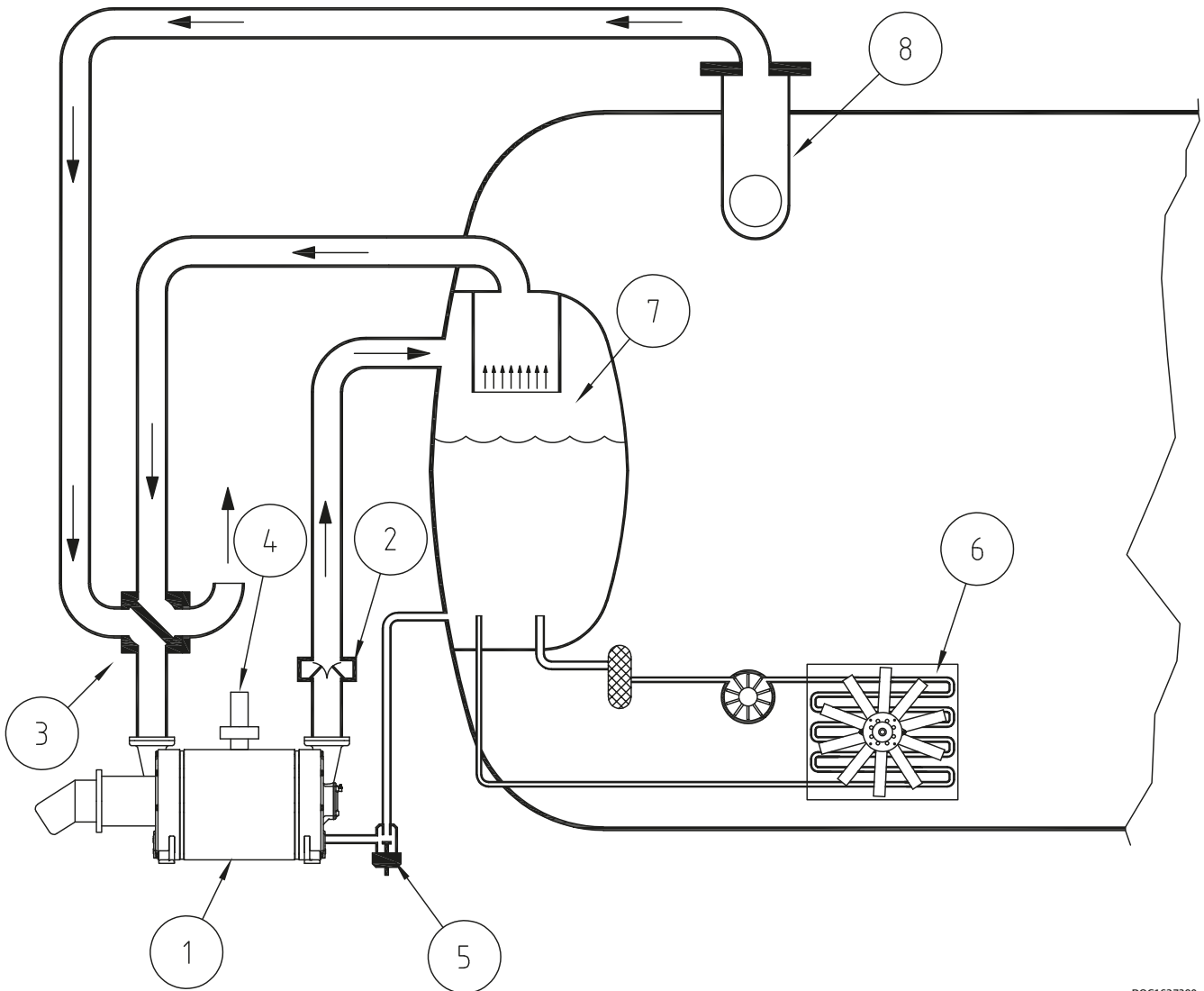

DOC1627390

Pos.	Description
1	Liquid ring pump
2	Non return valve
3	4-way valve
4	Vacuum control valve
5	Water control valve
6	Fan cooler
7	Liquid separator
8	Dome valve

3.1 Function and design of a liquid separator

Together with the air there will be a water flow out of the pump up to 6 m³/h.

The water will be separated from the air in the liquid separator.

Depending of the size of particles, water will be carried with the water when the air velocity is more than 3-4 m/s.

The inlet speed to the separator can be more than 50 m/s and this must be reduced to 3 m/s.

Below you find an illustration showing how to reduce the speed and control that no water will be in contact with the high velocity air stream. The round velocity reducer can be placed inside any tank geometry.

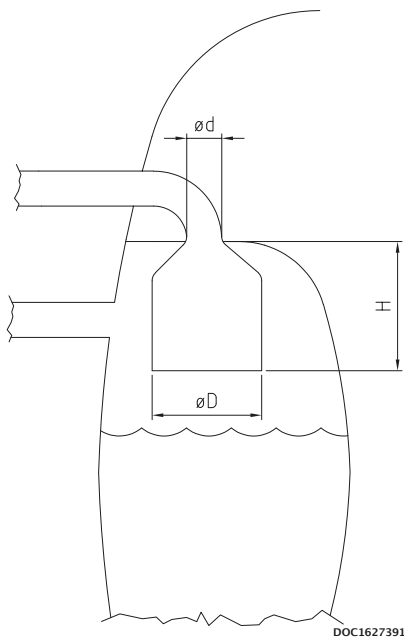

Air flow [m ³ /h]	øD minimum [mm]
3000	580
2800	570
2600	560
2400	540
2200	510
2000	490

øD so the velocity is below 3 m/s

H=4 to 6*d depending on the geometry. A smooth diameter conversion will give a low factor.

3.2 Air cooling with fan cooler

Compression of air inside the liquid ring pump will create heat that is transferred to the water.

Therefore, it can be necessary to install a fan cooler depending on the expected use, the climate etc. The time it takes to heat up the water also depends on for example ambient temperature, suction pressure, amount of water and the cooling effect in the truck itself.

The operation temperature will go up until there is a balance between the heat input and the heat output. So basically, there are only two things that can lower the operation temperature. Reduce the heat input or increase the heat output.

The amount of water has no or only a little influence on the final operating temperature. The truck itself will work as a big radiator and if there is a huge amount of water in the liquid separator and thereby good contact area between the water and the steel tank, it will give a higher cooling effect. This in combination with low ambient temperature and short time of operation, could mean that the truck can operate without any additional cooling.

In general, the time it takes to heat up the water can be calculated from the formula below.

$$t_{\text{sec}} = \frac{C_p \times m \times \Delta t}{Q}$$

t_{sec} = Time in seconds

C_p = Heat capacity of the media. Water= 4,2

Δt = Temperature difference

m = Mass of the media heating up [Kg]

Q = Heat input in [kW] See specifications, chapter 2.2

Example:

We have a tank with 300 litres of water corresponding to 300 kg. The heat input is 30 kW. How long will it take to heat it up from 20°C to 40°C ?

$$t_{\text{sec}} = \frac{4,2 \times 300 \times 20}{30} = 840 \text{ s} = \underline{14 \text{ min}}$$

The temperature will continue to go up until the steel construction can absorb the heat and transfer it to the surroundings.

With a temperature difference on 20°C it is typical to have a radiator effect in a truck on somewhere between 5 to 20 kW depending on the construction.

The table below shows truck radiator effect at a temperature difference of 20°C.

5 kW	10 kW	20 kW
Small liquid separator mounted external from the truck tank Water content below 100 L	Small liquid separator inside slurry tank. Located with only minor contact to the product Water content 300 L	Normal liquid separator inside slurry tank with good contact to the product Water content 400 L

3.3 Fan cooler

The fan cooler will increase the heat output from the construction and thereby stabilize the temperature at a lower level. However, this cooler will use the air to cool down the water and therefore we will always see that the temperature will be stabilized above the ambient temperature. It's very simple to find the right cooler based on the curves from the cooler manufacturer. Typically you will find the cooler capacity as kW/Δt meaning for example 1.5 kW cooler capacity each °C in temperature difference between the water and the air. Note that the water flow through the cooler will also affect the cooling capacity.

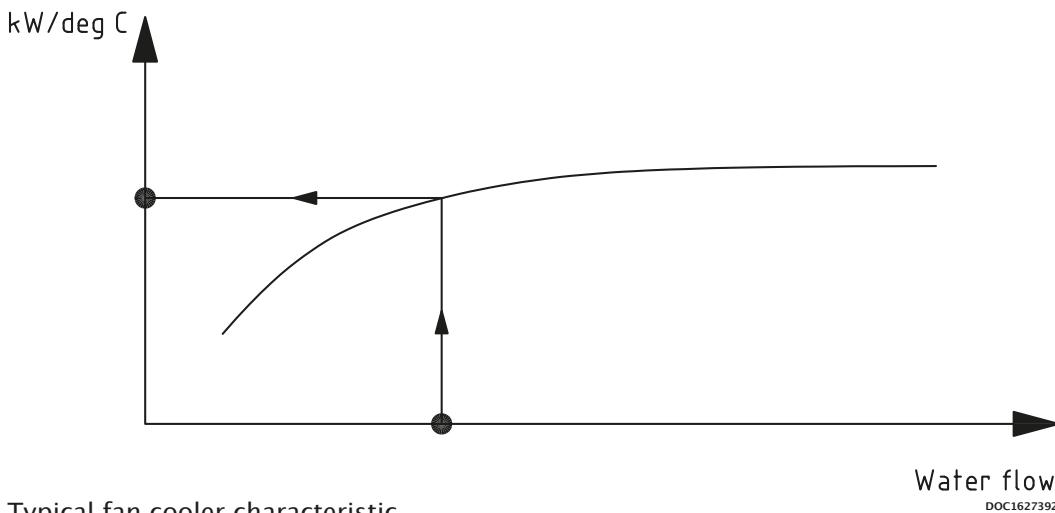

Typical fan cooler characteristic.

Practical calculation example:

The truck is used mostly to work with an operation pressure around 70% vacuum. From the technical data sheet, we find the heat input from the pump to be 68 kW.

The liquid separator is built inside the slurry tank with a good contact to the product and a radiator effect estimated to 20 kW with a temperature difference of 20°C.

The truck will work with ambient temperature up to 28°C during the summer and we will accept a maximum temperature on 40°C.

First, we have to reduce the radiator effect based on a temperature difference of 12°C.

$$Q_{\text{out Truck}} = 20 \times \frac{12}{20} = 12 \text{ kW}$$

The total cooling effect required is thereby:

$$Q_{\text{out Pump}} - Q_{\text{out Truck}} = 68 - 12 = \underline{56 \text{ kW}}$$

Summary

Pump model	Description	SLP 3100
Heat input from technical specifications	$Q_{in\ Pump}$	68 kW
Ambient temperature	t_{amb}	28°C
Maximum Working Temperature of the water. This is determined by you. The temperature has influence on the pump performance	t_{op}	40°C
Temperature difference	Δ_t	$t_{op} - t_{amb} = 12^\circ C$
Truck radiator effect based on 20 °C in temperature difference	$Q_{out\ Truck\ 20}$	20 kW
Truck radiator effect based on 12 °C in temperature difference	$Q_{out\ Truck\ 12}$	$12/20 * 20 = 12\ kW$
Total cooling requirement from fan cooler	$Q_{fan\ cooler}$	$Q_{in\ Pump} - Q_{out\ Truck\ 12} = 68 - 12 = 56\ kW$

We need to find a fan cooler that can transfer 56 kW with a temperature difference on 12°C. That is 4,6 kW/°C.

If we for example accept a higher temperature, for instance 48°C, we will have full cooling effect from the truck on 20 kW and a cooling requirement on 48 kW. The fan cooler we need to find is thereby on $48/20 = 2,4\ kW/^\circ C$ and a big difference to the bigger model calculated above.

3.4 Water consumption

It is possible to design the liquid separator so that almost 100% of the water is separated from the air. However, the air will be heated up and thereby it can contain more water. Also, the relative humidity will go up and end near 100%.

So, the air will flow into the pump with maybe 50% relative humidity at a low temperature and be discharged at a higher temperature and humidity. Therefore, there will be an evaporation from the system.

Choose your water temperature

Temp. \ Vacuum	20°C	30°C	40°C	50°C	55°C
50%	8/9/10	20/23/25	39/45/50	67/79/87	111/129/142
70%	4/5/5	10/12/13	19/23/26	33/40/46	54/66/75
80%	2/2/3	6/6/7	11/11/13	19/19/23	31/32/37

Water consumption Liters per hour (SLP2100/2700/3100)

3.5 Dome valve system

The liquid ring pump can handle liquid and particles in the inlet but it is of course recommendable to avoid this.

A dome valve or floating valve will ensure that the suction will be closed when the liquid level reaches the top of the tank.

In many situations there will be foam on the liquid surface inside the tank. It can be difficult to avoid that this will be transported into the suction line before the dome valve will close.

Therefore, it will be recommended to make a combination of a filter and dome valve as illustrated below.

The filter will prevent particles lifted by the foam to enter the pump.

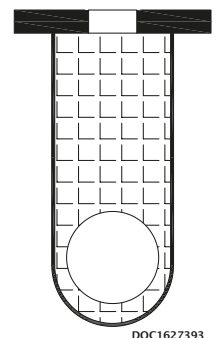

3.6 Cavitation

When the temperature reaches the boiling point of the water, steam bobbles will be created in the liquid ring.

These bobbles cannot exist when they enter the discharge side of the pump and therefore they will collapse. The impact force on the surface of the rotor and flow plate will damage the pump and can lead to a total breakdown. It is a very harmful situation that must be avoided.

It is the combination of the pressure and the temperature that will lead to the cavitation. Therefore, it is recommended to install 2 vacuum control valves, see illustration below that shows a clockwise rotating pump. If counter-clockwise rotating pump, mount in opposite manifold.

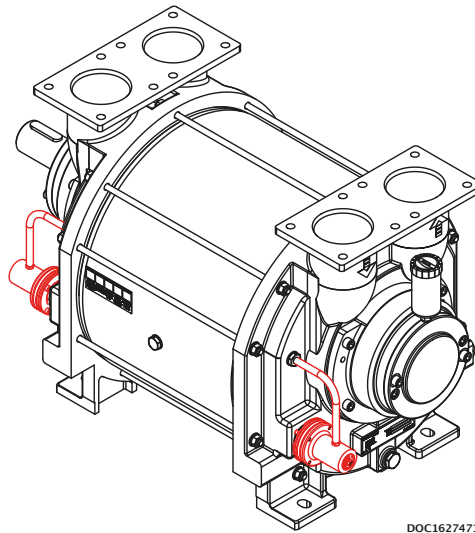

Below you find the boiling point of water as a function of the pressure.

Vacuum	50%	75%	80%	90%
Temperature °C	80	64	59	44
Maximum discharge temperature	70	50	40	30

Note that the temperature of the gas inside the pump will heat up the water and the water surface therefore will become a higher temperature than the measured temperature on the discharge side of the pump. Cavitation will therefore start at a lower temperature and the maximum discharge temperature of the water must be kept lower.

3.7 Water requirement

During operation it is normal that small amount of product will enter the pump, or the gas will react with the water which can become aggressive.

Drain the liquid separator and refill with fresh water, if the water has become aggressive.

4 INSTALLATION AND START-UP

4.1 Securing the pump



Installation requirements must be observed, otherwise there is a risk of damage

The pump must be installed on a stable foundation, which must be level and stable, so that the pump is not twisted or exposed to a profile distortion.

The pump must be installed with M16 bolts on all four legs, which must be tightened to 180 Nm (A).

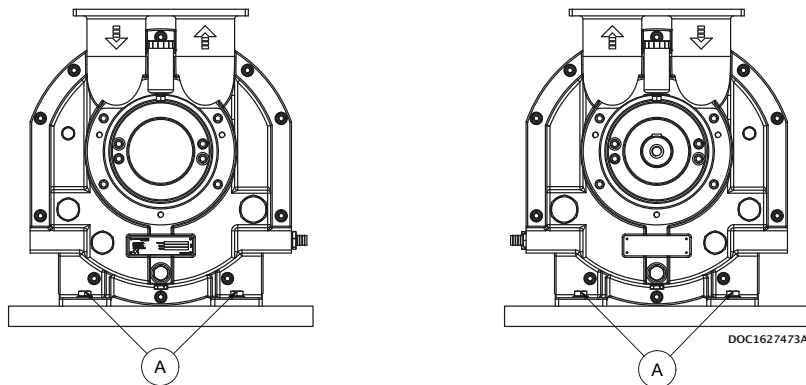

4.2 Connections to the pump



- Check for foreign objects in the pump and physical damage on pump
- Gaskets to be handled with highest degree of caution
- Gasket and sealing surfaces must be cleaned before assembly

Immediate before connecting the pipes, remove protective covers. Connection of the pump's suction and pressure pipe connections must be made with a gasket in between (C).

The M16 bolts must be tightened with 180 Nm (B).

In order to prevent tensions in the pump, the pipe connections (A) must be tensionless while tightening the bolts.

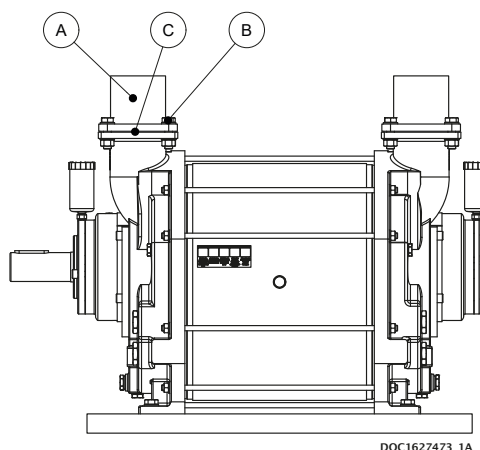

4.3 Connecting the water

The water must be connected to the pump at the hose connection (B), see illustration below.

If required, the hose nipple can be dismantled from (B) and mounted on desired location (A).

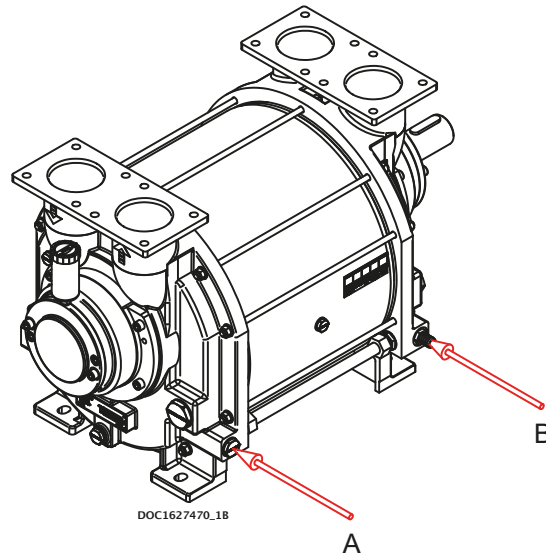

4.4 Transmission

The pump can be connected direct or through belt transmission. For belt transmission, it must be ensured that the permissible radial force is not exceeded. See specifications.

For belt transmission, note the direction of rotation, see illustration below.

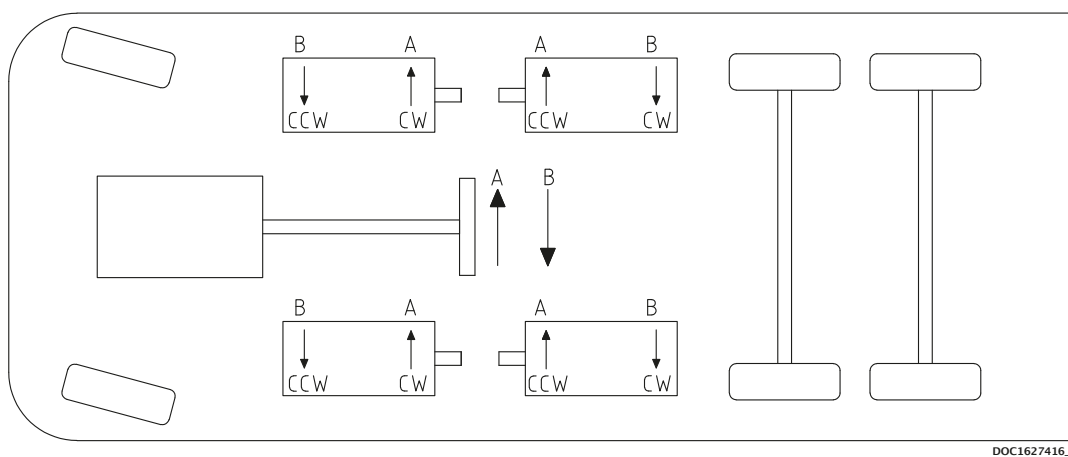

DOC1627416.1

4.5 Prior to start-up



- Do not start the pump without water, as this will damage the mechanical shaft seals
- Do not start the pump if it is completely filled with water
- Do not start the pump before the grease cartridges have been activated, as this can damage the pump (if equipped)
- Stop the pump immediately if the rotational direction does not correspond to the directional arrow
- A failure to follow the above guidelines may result in damage to the pump

Activating the grease cartridges (Accessories)

Turn the handle in NDE clockwise to position 12.
Turn the handle in DE clockwise to position 12.
The pump has been lubricated from factory and is ready to start.

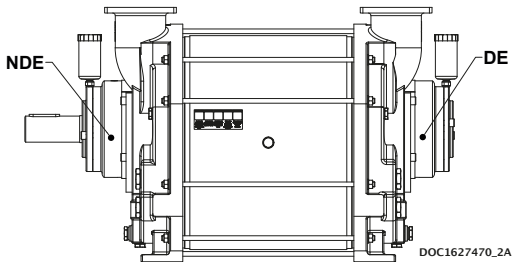

4.6 Direction of rotation

Check the direction of rotation by briefly starting the pump.

The direction of rotation of the rotor must correspond to the direction arrow!

Below left, a right-side pump is shown which has a clockwise direction of rotation (CW)

Below right, a left-side pump is shown which has a counter-clockwise direction of rotation (CCW)

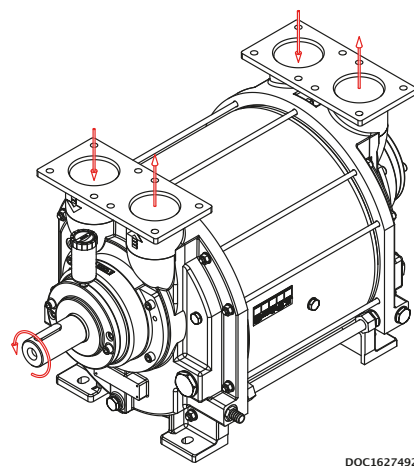
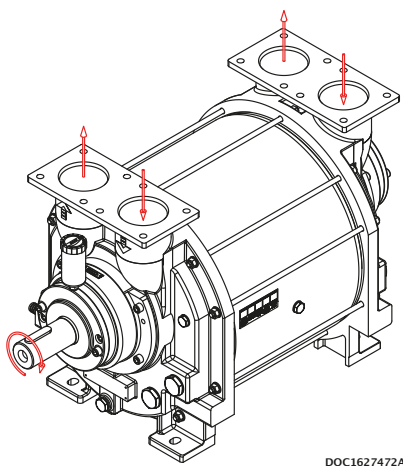

5 SERVICE, OPERATION, MAINTENANCE AND INSPECTION INTERVALS



A failure to observe the inspection intervals described in table below may result in damage to the pump

Section	Operation	Interval
5.1	Drain liquid separator and pump to remove contaminants	Daily
5.2	Check grease cartridges (if equipped)	Weekly
5.3	Winterization	When below 0°C
5.4	Lubrication of bearings	Per 500 duty hours
5.5	Inspection and cleaning of service liquid's supply pipe	Monthly
5.6	Inspection and cleaning of internal channels	Monthly

5.1 Draining the liquid separator and the pump

While the pump is stopped, the liquid separator must be drained to remove contaminants.

Drain the pump in C₁ or C₂, see chapter 2.5.

5.2 Check grease cartridges

If the pump is equipped with an automatic lubrication feature. It must be inspected and replaced as needed.

When the pump is commissioned for the first time, the cartridges must be activated by turning the arrow in the clockwise direction.

The cartridge is set to 12, which corresponds to an emptying time of 12 months. The cartridge must be replaced when empty.

It is only allowed to use automatic lubricator of type **LAGD 125/WA2**.



5.3 Winterization

If the pump needs to be used at a temperature below freezing point of the water, it is necessary to protect the water from freezing by adding anti freeze liquid.

5.4 Lubrication of bearings



Over-lubrication of bearings may result in bearing damage! Do NOT exceed the amount of grease specified below!

The bearings must be lubricated with grease of type SKF LGWA2, per 500 duty hours. It is recommended to lubricate the bearings while pump is running.

Lubrication interval per 500 duty hours

Drive end (DE)	SLP2100/2700/3100	116 g
Non drive end (NDE)	SLP2100/2700/3100	39 g

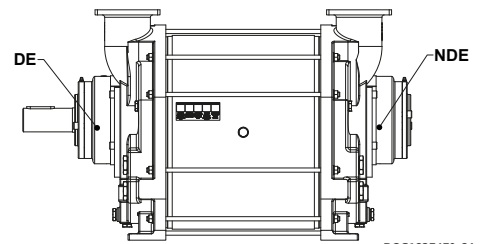

DOC1627470_3A

5.5 Inspection and cleaning of water supply pipe

The pipe connection between the liquid separator and pump must be inspected at least once a month, and any contaminants must be removed.

5.6 Inspection and cleaning of internal channels

The pump is designed with internal water channels for lubrication of the mechanical shaft seals. Remove the plug as illustrated below and clean the channel using a $\varnothing 5$ mm 150 mm long screw driver or similar.

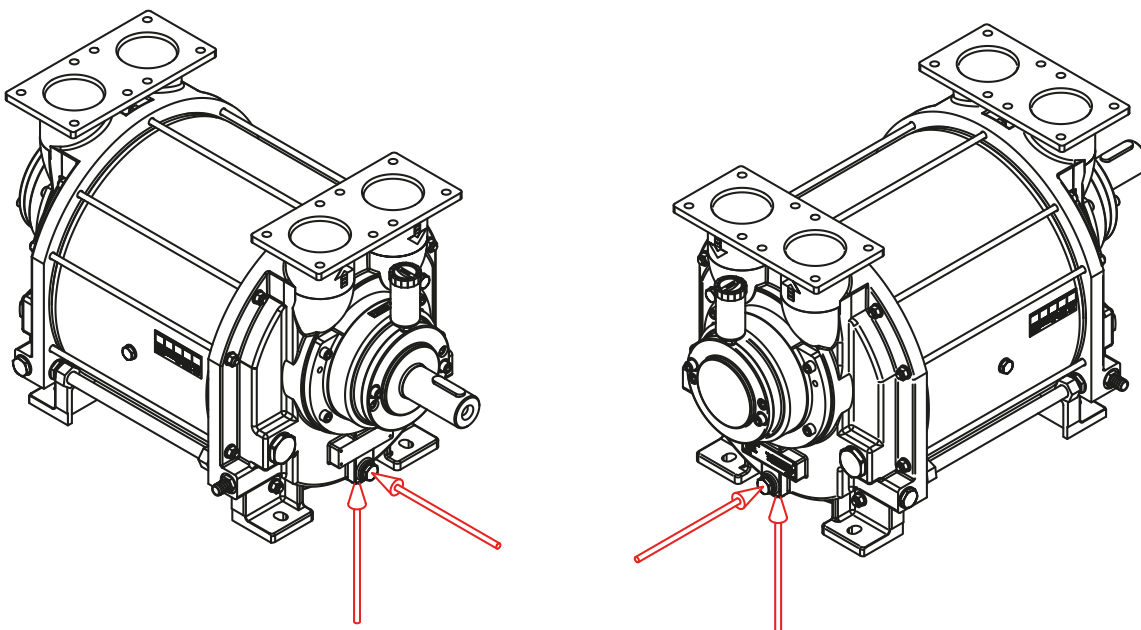

DOC1627470_4A

6 TROUBLESHOOTING

Problem	Cause	Effect	Corrective measure
The pump is unable to create a vacuum	<ul style="list-style-type: none"> • Water control valve is closed • The pump is not receiving enough water • The temperature of the water is too high 	<ul style="list-style-type: none"> • Reduced output • The pump can become damaged during cavitation 	<ul style="list-style-type: none"> • Check water control valve • Check the water supply • Stop the pump and wait until the temperature has dropped to a sufficient level, or lower the temperature of the water inlet
The start-up power is too high	<ul style="list-style-type: none"> • Too much water in the pump prior to start-up 	<ul style="list-style-type: none"> • Noise at start-up and possible overload of the power supply 	<ul style="list-style-type: none"> • Check the stop valves in the water supply for leakage
Noise during operation	<ul style="list-style-type: none"> • Cavitation 	<ul style="list-style-type: none"> • Severe damage to the pump and potential risk of breakdown 	<ul style="list-style-type: none"> • Increase the suction pressure or lower the temperature of the water
Leakage from the bearing housing's drain holes	<ul style="list-style-type: none"> • Damaged shaft seal 	<ul style="list-style-type: none"> • Bearings may become damaged • Potential risk of explosive gas leak 	<ul style="list-style-type: none"> • Stop the pump and contact the manufacturer

7 SPARE PARTS AND TOOLS

7.1 Marking and identification

The pump is equipped with an identification plate as shown below.



Configuration example:

SLP 3100 R 0 S S E 1 0 T SD

- Type:
- Model:
- Rotation:
- Rotor type:
- Pump housing:
- Shell:
- Flow plates:
- Generation of pump:
- Gaskets:
- Colour:
- Documentation:

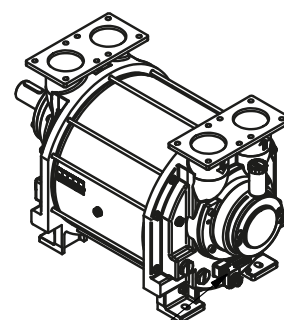
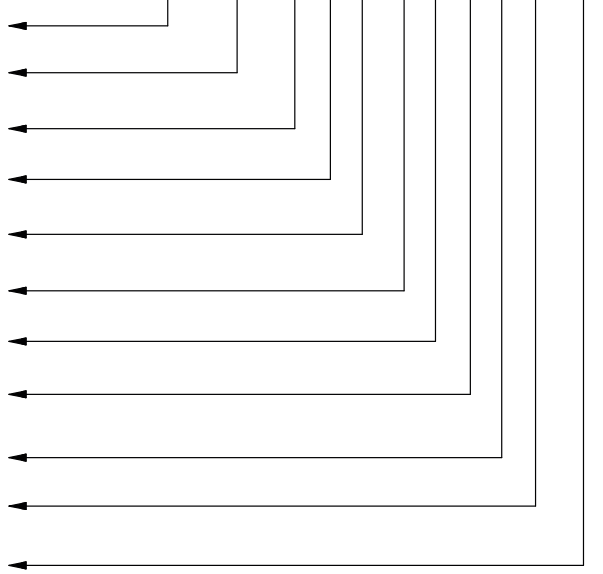

Location of ID plate

DOC107973B

7.2 How to order

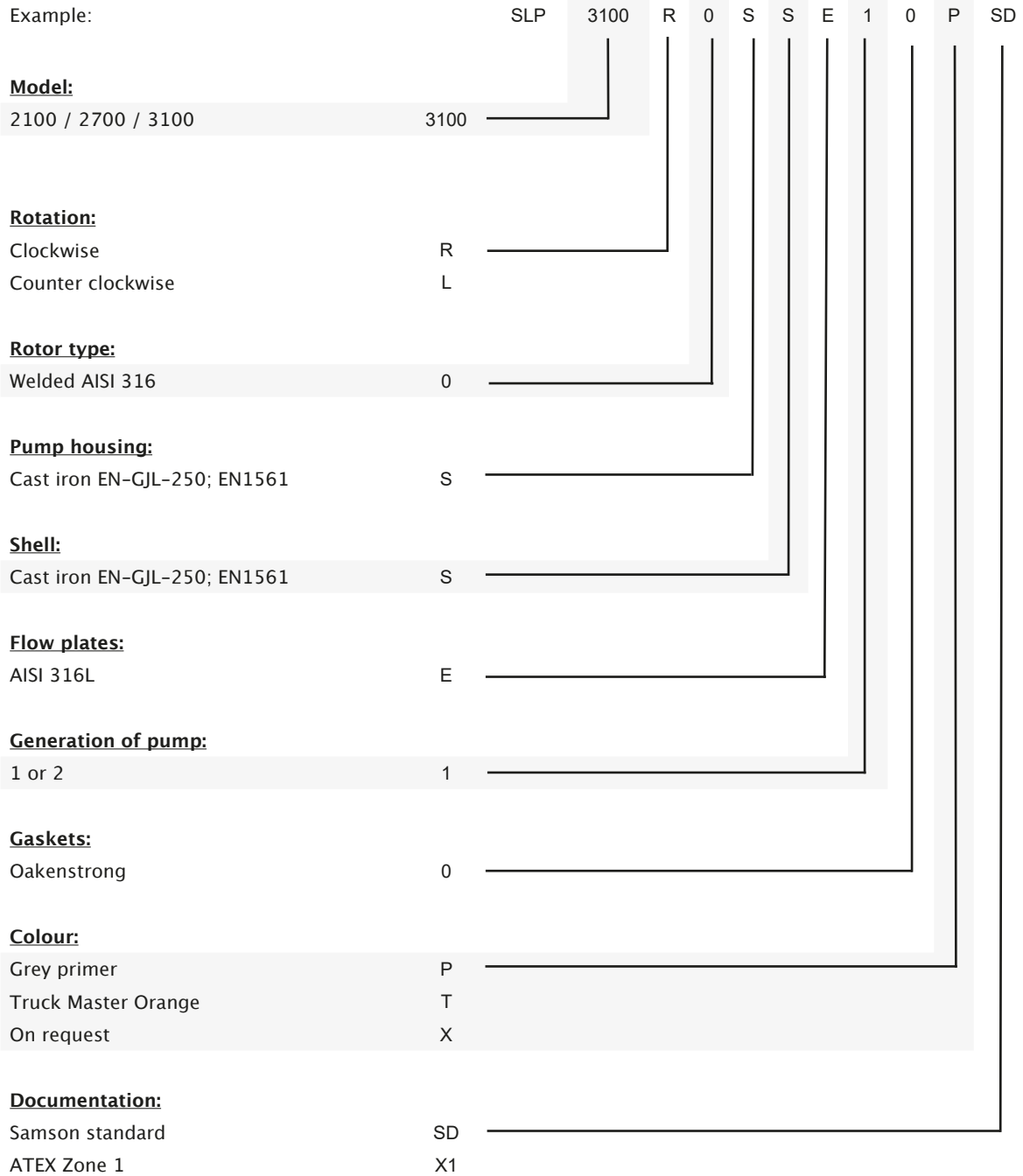

7.3 Spare parts - SLP

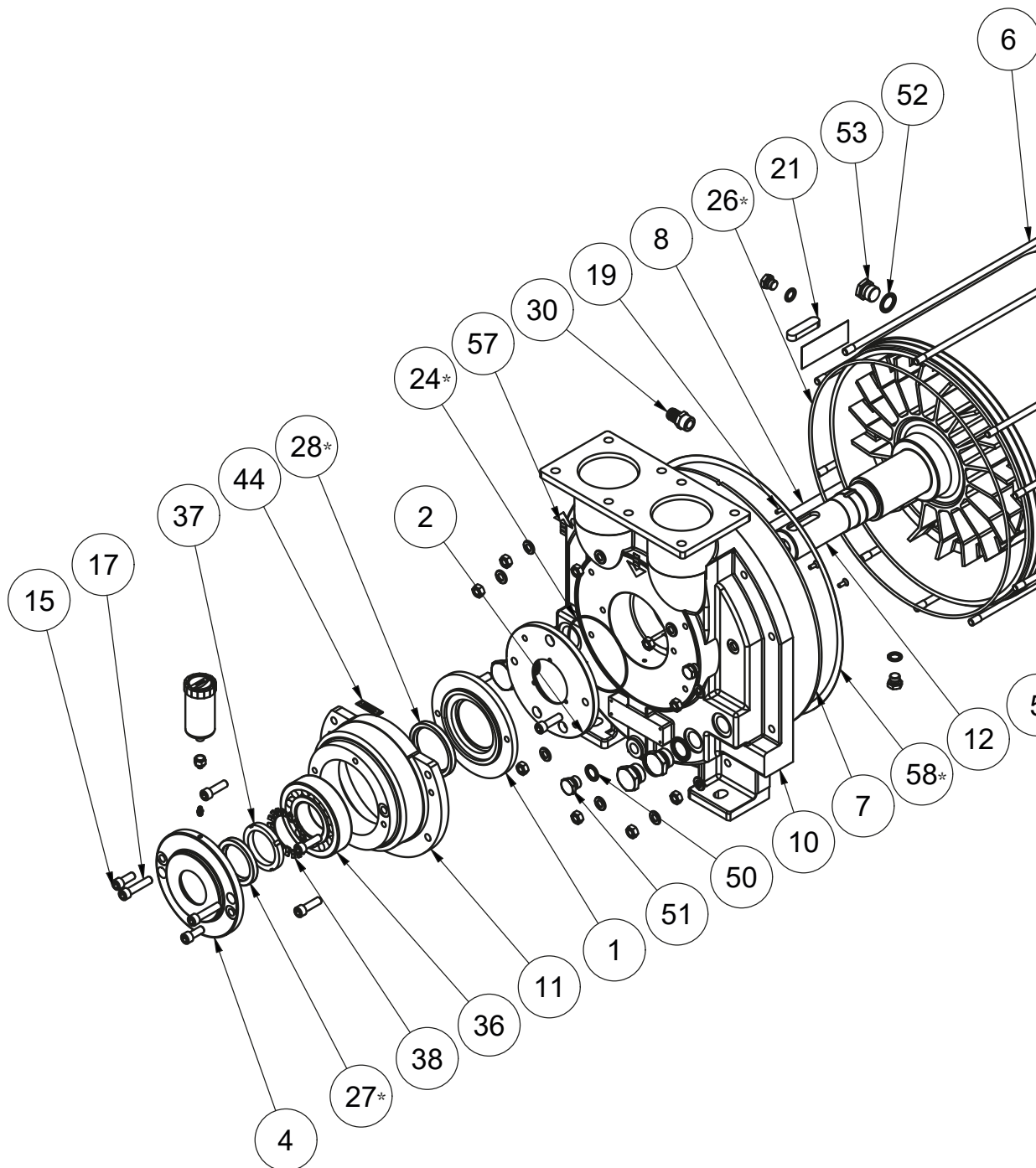

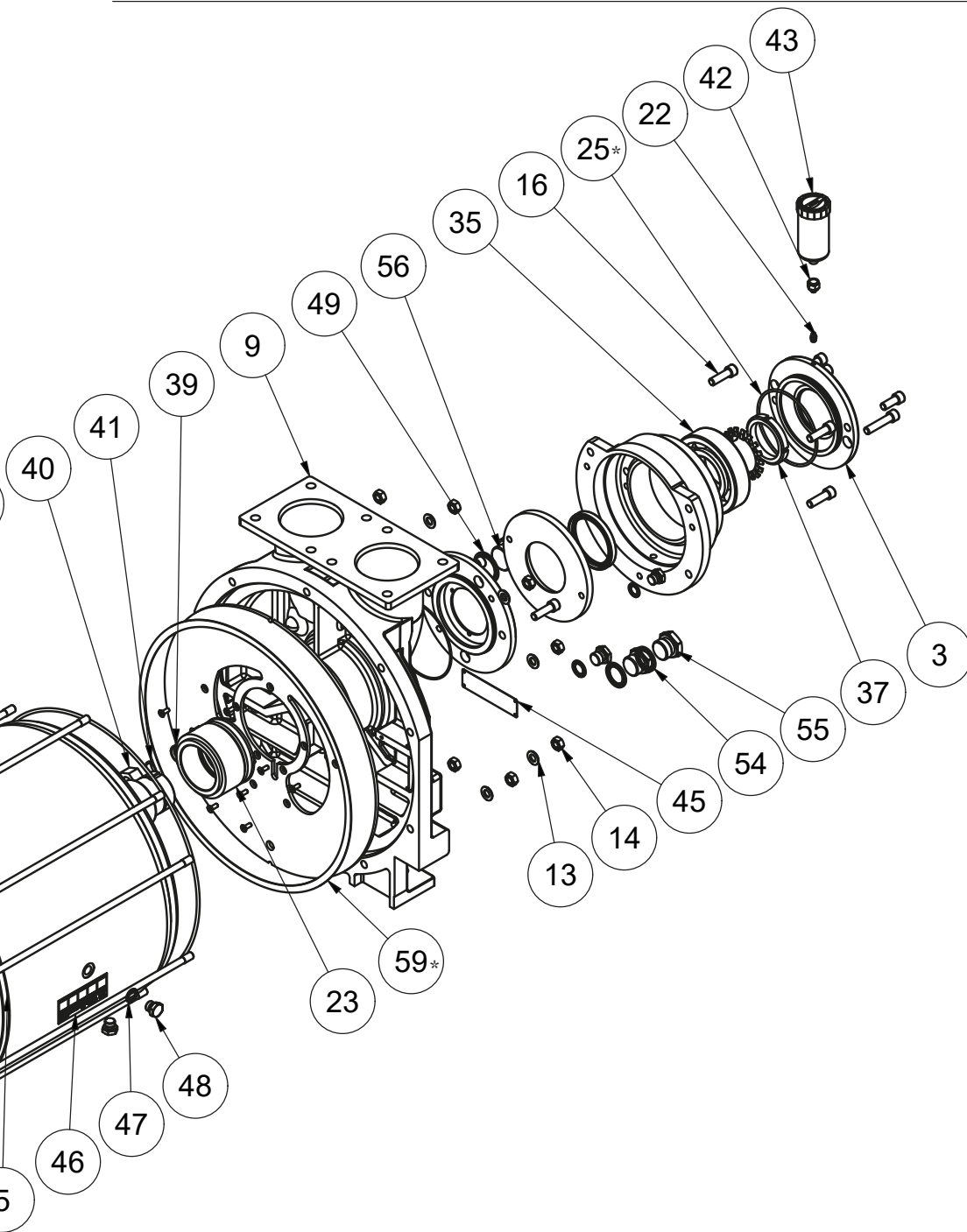

* - Included in gasket set.

Pos.	Part number	Description	Qty.	Material
1	1620036	Rear cap	2	Stainless steel
2	1620052	Retainer	2	Stainless steel
3	1620181	Bearing cover NDE	1	Cast iron
4	1620182	Bearing cover DE	1	Cast iron
5*	1653042	Shell SLP 2100	1	Cast iron
	1653041	Shell SLP 2700	1	Cast iron
	1653002	Shell SLP 3100	1	Cast iron
6*	1653063	Stay bolt SLP 2100	10	Steel
	1653062	Stay bolt SLP 2700	10	Steel
	1653005	Stay bolt SLP 3100	10	Steel
7	1653025	Flow plate	2	Stainless steel
8*	1653067	Service liquid supply pipe SLP 2100	1	Steel
	1653066	Service liquid supply pipe SLP 2700	1	Steel
	1653031	Service liquid supply pipe SLP 3100	1	Steel
9	1653033	Pump housing NDE	1	Cast iron
10	1653034	Pump housing DE	1	Cast iron
11	1653036	Bearing housing	2	Cast iron
12*	1653049	Rotor SPL 2100R	1	Stainless steel
	1653043	Rotor SLP 2700R	1	Stainless steel
	1653038	Rotor SLP 3100R	1	Stainless steel
13	910100016	Washer	20	Steel
14	910200010	Nut	20	Steel
15	910300074	Allen screw	4	Steel
16	910300482	Allen screw	12	Steel
17	910300080	M12x55 Allen bolt	4	Steel
18	910300194	Plug	3	Stainless steel
19	910300485	Hexagon socket countersunk screw	18	Stainless steel
20	910300281	Plug	2	Steel
21	915000024	Parallel key	1	Steel
22	915000050	Grease nipple	2	Steel
23	922000259	Mechanical shaft seal	2	Steel
24	1653060	Gasket set SLP 2100/2700/3100	1	-
25	1653060	Gasket set SLP 2100/2700/3100	1	-
26	1653060	Gasket set SLP 2100/2700/3100	1	-
27	1653060	Gasket set SLP 2100/2700/3100	1	-
28	1653060	Gasket set SLP 2100/2700/3100	1	-
30	925000240	Hose nipple	1	Brass

* -See section 7.1 for identification of pump.

**-Optional. Not equipped as standard.

Pos.	Part number	Description	Qty.	Material
35	930000296	Ball bearing	1	Steel
36	930000297	Spherical roller bearing	1	Steel
37	930200022	Shaft nut	2	Steel
38	930200025	Lock washer	2	Steel
39	938000156	Fitting	2	Stainless steel
40	938000157	Fitting	2	Stainless steel
41	938000158	Fitting	2	Stainless steel
42**	1634773	Hexagonal bushing	2	Stainless steel
43**	915000225	Automatic lubricator LAGD 125/WA2	2	Plastic / grease
44	-	Direction arrow	1	Aluminum
45	-	Identification plate	1	Stainless steel
46	1624074	Label	1	Plastic foil
47	922000269	Bonded seal	6	Brass / rubber
48	1634809	Plug	6	Stainless steel
49	922000272	Bonded seal	2	Brass / rubber
50	922000268	Bonded seal	2	Brass / rubber
51	1634810	Plug	2	Stainless steel
52	922000266	Bonded seal	1	Brass / rubber
53	1634811	Plug	1	Stainless steel
54	922000267	Bonded seal	3	Brass / rubber
55	1634812	Plug	3	Stainless steel
56	1634817	Plug	2	Stainless steel
57	1624054	Arrow label	4	Plastic foil
58	1653060	Gasket set SLP 2100/2700/3100	1	-
59	1653060	Gasket set SLP 2100/2700/3100	1	-

* -See section 7.1 for identification of pump.

**-Optional. Not equipped as standard.

7.4 Spare parts - SL

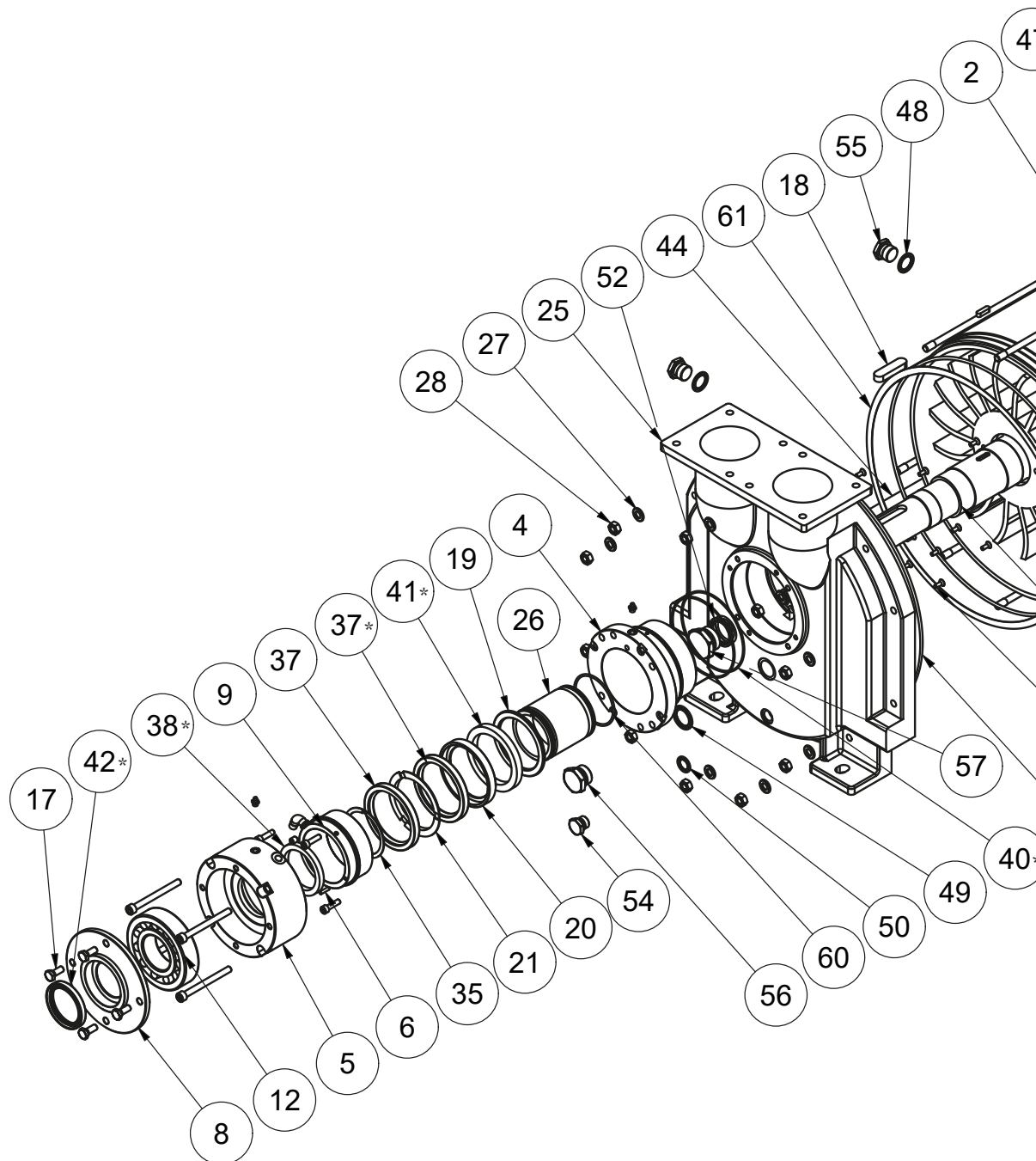

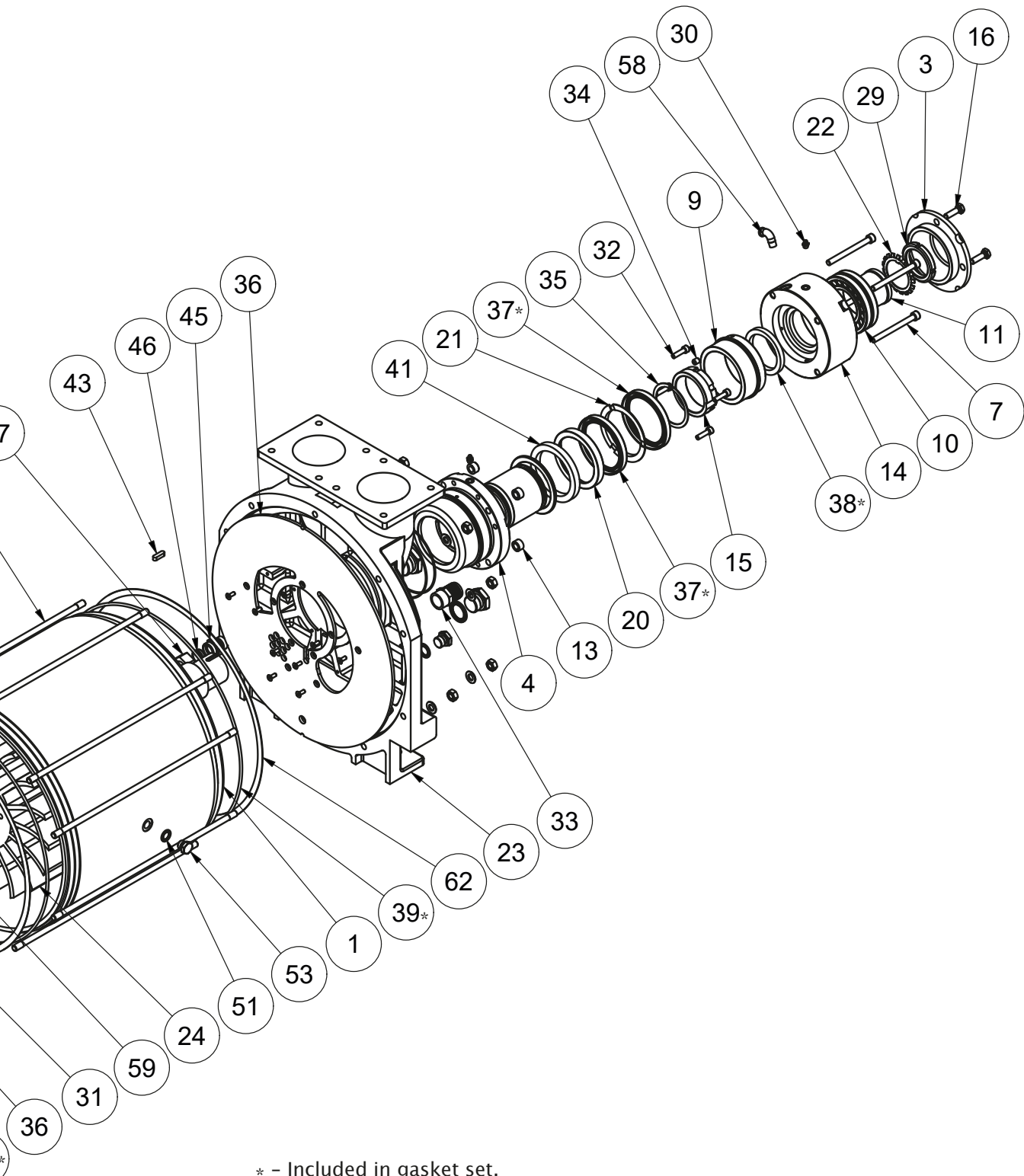

* - Included in gasket set.

Pos.	Part number	Description	Qty.	Material
1*	1653042	Shell SLP 2100	1	Cast iron
	1653041	Shell SLP 2700	1	Cast iron
	1653002	Shell SLP 3100	1	Cast iron
2*	1653063	Stay bolt SLP 2100	10	Steel
	1653062	Stay bolt SLP 2700	10	Steel
	1653005	Stay bolt SLP 3100	10	Steel
3	N/A	Bearing cover NDE	1	Cast iron
4	N/A	Adapter	2	Stainless steel
5	N/A	Bearing housing DE	1	Cast iron
6	915000239	Hardened parallel pin	1	Stainless steel
7	910300478	M10x110 Allen bolt	8	Stainless steel
8	N/A	Bearing cover DE	1	Cast iron
9	N/A	Bearing housing adapter	2	Steel
10	1653070	Bearing set SL 2100/2700/3100	1	-
11	1653070	Bearing set SL 2100/2700/3100	1	-
12	930000297	Spherical roller bearing	1	Steel
13	N/A	Spacer bushing	4	Steel
14	N/A	Bearing housing NDE	1	Cast iron
15	N/A	Lock nut	2	Steel
16	910000024	Hexagonal head screw	4	Stainless steel
17	910000023	Hexagonal head screw	4	Stainless steel
18	915000024	Parallel key	1	Steel
19	N/A	Washer	2	Steel
20	N/A	Bushing	2	Steel
21	N/A	Special disc	2	Steel
22	1653070	Bearing set SL 2100/2700/3100	1	-
23	N/A	Pump housing NDE	1	Cast iron
24	N/A	Rotor SL 3100	1	Stainless steel
25	N/A	Pump housing DE	1	Cast iron
26	N/A	Bushing	2	Steel
27	910100155	Washer	20	Steel
28	910200013	Nut	20	Steel
29	1653070	Bearing set SL 2100/2700/3100	1	-
30	915000053	Grease nipple	4	Steel
31	910300268	Hexagon socket countersunk screw	18	Stainless steel
32	910300267	Allen screw	8	Stainless steel
33	925000240	Hose nipple	1	Brass
34	910300281	Plug	2	Steel

* -See section 7.1 for identification of pump.

Pos.	Part number	Description	Qty.	Material
35	N/A	Special washer	2	Steel
36	1653025	Flow plate	2	Stainless steel
37	1653061	Gasket set SL 2100/2700/3100	1	-
38	1653061	Gasket set SL 2100/2700/3100	1	-
39	1653061	Gasket set SL 2100/2700/3100	1	-
40	1653061	Gasket set SL 2100/2700/3100	1	-
41	1653061	Gasket set SL 2100/2700/3100	1	-
42	1653061	Gasket set SL 2100/2700/3100	1	-
43	915000240	Parallel key 8x7x28	2	Steel
	1653067	Service liquid supply pipe SLP 2100	1	Steel
44*	1653066	Service liquid supply pipe SLP 2700	1	Steel
	1653031	Service liquid supply pipe SLP 3100	1	Steel
45	938000156	Fitting	2	Stainless steel
46	938000158	Fitting	2	Stainless steel
47	938000157	Fitting	2	Stainless steel
48	922000266	Bonded seal	1	Brass / rubber
49	922000267	Bonded seal	2	Brass / rubber
50	922000268	Bonded seal	2	Brass / rubber
51	922000269	Bonded seal	2	Brass / rubber
52	922000272	Bonded seal	2	Brass / rubber
53	1634809	Plug	2	Stainless steel
54	1634810	Plug	2	Stainless steel
55	1634811	Plug	1	Stainless steel
56	1634812	Plug	2	Stainless steel
57	1634817	Plug	2	Stainless steel
58	925000863	Fitting	2	Stainless steel
59	N/A	Rotor shaft SL 3100	1	Stainless steel
60	922100374	O-ring 89,40 X 3,10	2	Rubber

* -See section 7.1 for identification of pump.

7.5 Adaptor

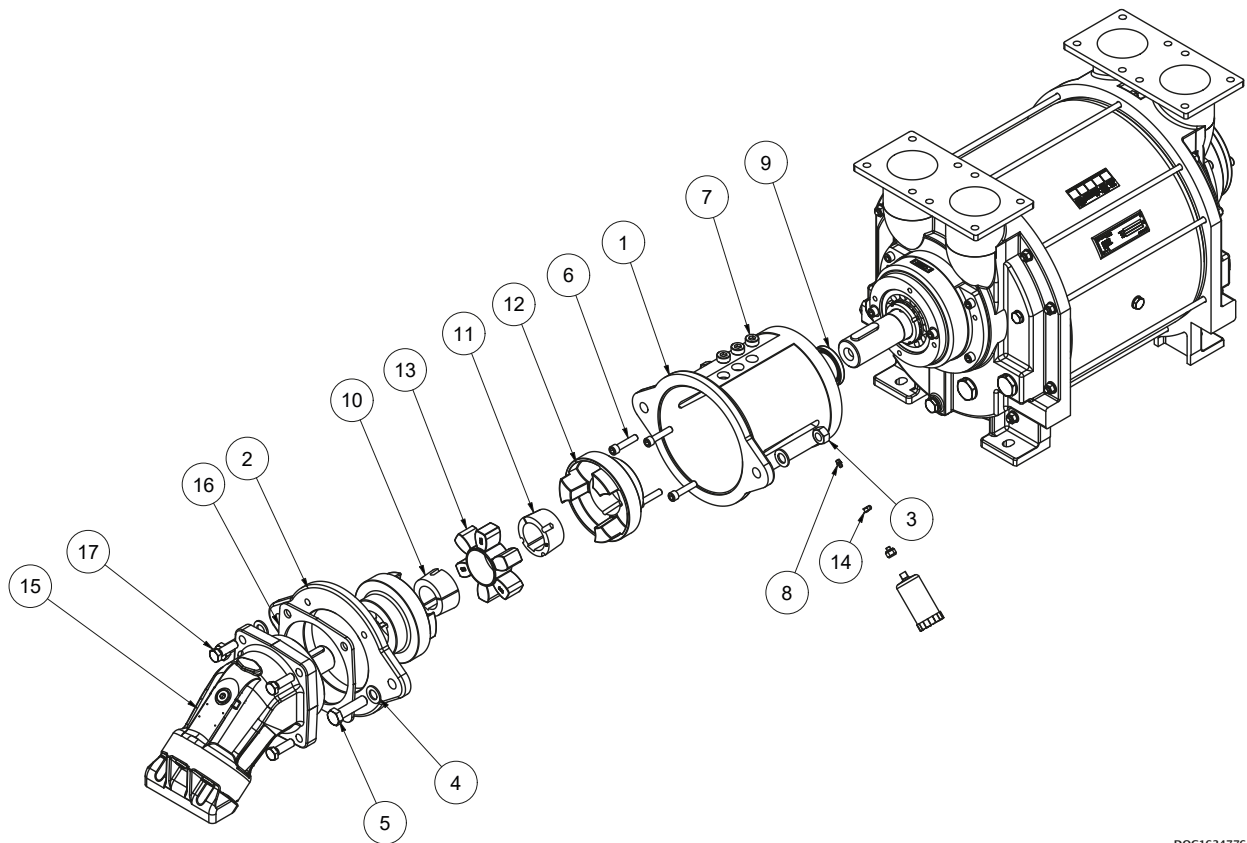

DOC1634776_4

Pos.	Part number	Description	Qty.	Material
1	1634621	Adaptor	1	Cast iron
2	1634768	SLP2700/3100 Flange for motor model: 152 ISO	1	Cast iron
3	910000422	M20 Nut	2	Steel
4	910000423	M20 Washer	4	Steel
5	910000508	M20x75 Bolt	2	Steel
6	910300079	M12x55 Allen bolt	4	Stainless steel
7	910300186	Plug 3/4"	3	Steel
8	915000050	Grease nipple	1	Steel
9	922200075	Radial shaft seal	1	Rubber / Steel
10	932300060	Taperlock bush	1	Cast iron
11	932300028	Taperlock bush	1	Cast iron
12	932400048	Half coupling	2	Cast iron
13	932400049	Rubber element	1	Rubber
14	948300058	Grease nipple cap	1	Plastic
15	944000082	Hydraulic motor	1	Steel
16	1634816	Spacer flange for hydraulic motor	1	Steel
17	910000407	M16x50 Hexagon head bolt	4	Steel

7.6 Gasket set – SLP



DOC11740

Pos.	Part number	Description	Qty.	Material
24	922100331	O-ring Ø134x2,5	2	Rubber
25	922100332	O-ring Ø129,77x3,53	1	Rubber
26	922100372	O-ring Ø470x5	2	Rubber
27	922200075	Radial shaft seal 62x85x10	1	Rubber / Steel
28	922200155	Radial shaft seal 80x100x10	2	Rubber / Steel
58	1653068	Gasket shell / flow plate 0,5 mm	2	Paper
59	1653069	Gasket shell / flow plate 1 mm	2	Paper

See spare parts drawing (DOC1653035C) for positions.

7.7 Gasket set - SL



DOC11739

Pos.	Part number	Description	Qty.	Material
37	922200267	Radial shaft seal 95x120x12	4	Rubber / Steel
38	922200268	Radial shaft seal WC_75_95_10	2	Rubber / Steel
39	922100372	O-ring Ø470 x 5	2	Rubber
40	922100373	O-ring 145,00 X 2,50	4	Rubber
41	1653059	Gland packing	2	Fiber
42	922200077	Radial shaft seal 65x85x10	1	Rubber / Steel

See spare parts drawing (DOC1653057) for positions.

7.8 Bearing set – SL



DOC11741

Pos.	Part number	Description	Qty.	Material
10	930000318	Spherical roller bearing tapered bore	1	Steel
11	930200053	Withdrawal sleeve	1	Steel
22	930200054	Lock washer	1	Steel
29	930200052	Shaft nut	1	Steel
N/A	930200058	Lock nut	1	Steel

See spare parts drawing (DOC1653057) for positions.

7.9 Special tool set – SLP

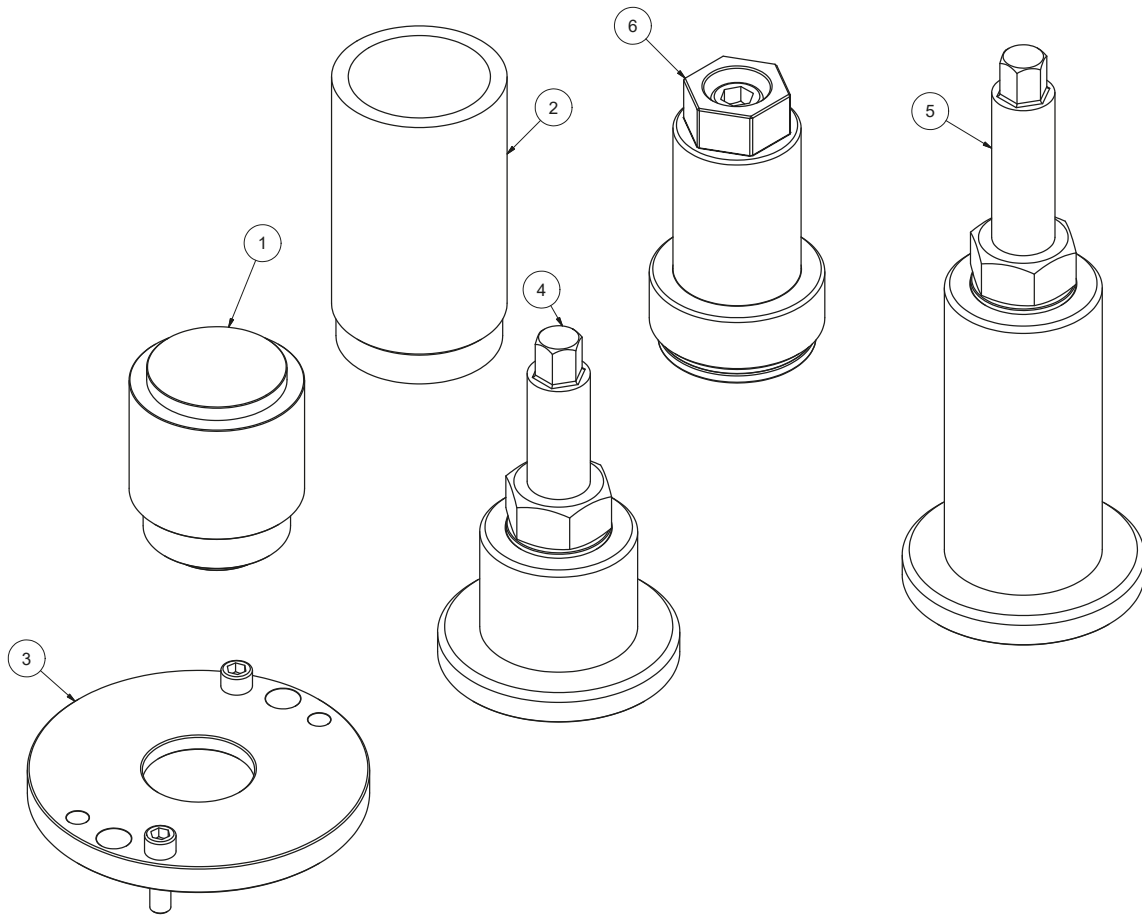

DOC1629270_1

Pos.	Part number	Description	Qty.	Material
1	1629171	Mandrel radial shaft seal Ø85 + Ø100	1	Plastic
2	1629117	Mechanical shaft seal tool	1	Plastic
3	1629173	Machined bearing cap set	1	Steel
4	1629115	Bearing mounting tool set NDE	1	Steel
5	1629116	Bearing mounting tool set DE	1	Steel
6	1629272	Bearing tool set	1	Steel

SAMSON PUMPS

Samson Pumps is the only company in the world to specialize in liquid ring vacuum pumps. The pumps are made in Denmark and used all around the globe.

Truck Master, Ocean Master and Industrial Series Gamma are the company's three brands. Truck Master Series is designed and optimized for the vacuum truck market. Ocean Master Series is meant for the fish industry where the pumps are usually installed onboard fishing vessels. Gamma Series is designed to handle the harshest industrial vacuum jobs.

At the core of Samson Pumps' activity is the strong belief that our liquid ring vacuum pumps must be of superlative quality for our customers to focus on what they do best. We always improve the quality and design of our pumps to better suit the vacuum units built by OEMs all around the globe.

Strength and durability are our hallmarks! Time and time again we hear from our satisfied customers that our pumps continue operating year after year and in most cases without the need for maintenance or repair. Samson Pumps is your reliable liquid ring vacuum pump supplier.