

# 4way valves for suction vehicles

INSTALLATION  
OPERATION  
MAINTENANCE



ATEX APPROVED



MODELS:  
DN80  
DN100  
DN125

## Table of contents

Page	Chapter	
3	<b>1</b>	<b>Introduction</b>
3	1.1	Declaration of Conformity
4	1.2	Digital services
4	1.3	Foreword
4	1.4	Explanation of warning symbols
4	1.5	ATEX Directive 2014/34/EU (ATEX approved only)
4	1.6	Field of application
5	<b>2</b>	<b>Technical data</b>
5	2.1	Dimensions with pneumatic actuator
6	2.2	Dimensions - With handle bar
7	2.3	Specifications
7	2.4	Operating the 4way valve
7	2.5	Storage
7	2.6	Handling and transport
7	2.7	Materials
8	2.8	4way valve parts
8	2.9	Pneumatic actuator parts
8	<b>3</b>	<b>Vehicle integration &amp; installation</b>
8	3.1	3-way pneumatic actuator positions
9	3.2	Adjusting the actuator positioning
10	3.3	Positions - Pneumatic actuator
10	3.4	Positions - With handle bar
11	3.5	Placing the 4way valve
11	3.6	Securing the 4way valve
11	3.7	Flange connections
12	<b>4</b>	<b>Service, maintenance &amp; inspection intervals</b>
12	4.1	Inspecting for leakage
12	4.2	Inspection and cleaning
12	4.3	Marking and identification

# 1 Introduction

## 1.1 Declaration of Conformity

**SAMSON  
PUMPS**

### Declaration of Conformity

Annex IIA

#### Samson Pumps A/S

Petersmindevej 21  
DK-8800 Viborg

Hereby declares that the following products:

4way valve with pneumatic actuator & 3 positioning switch  
4way valve with pneumatic actuator & 3 positioning switch (According to ATEX directive 2014/34/EU)  
4way valve with pneumatic actuator (According to ATEX directive 2014/34/EU)  
4way valve with manual shifting handle (According to ATEX directive 2014/34/EU)  
4way valve only (According to ATEX directive 2014/34/EU)

Conforms to the following directives:

Machinery Directive 2006/42/EC  
ATEX Directive 2014/34/EU (ATEX approved products only)

Explosion protection as follows on nameplate:

 II 1G Ex h IIC T4 Ga Internal

 II 2G Ex h IIC T4 Gb External

I hereby declare, that the machine are in conformity with the following harmonized standards:

DS/EN ISO 12100:2011	Safety of machinery - General principles for design - Risk assessment and risk reduction
DS/EN 1127-1:2019	Explosive atmospheres - Explosion prevention and protection - part 1: Basic concepts and methodology
DS/EN ISO 80079-36:2016	Explosive atmospheres - Part 36: Non-electrical equipment for explosive atmospheres - Basic method and requirements
DS/EN ISO 80079-37:2016	Explosive atmospheres - Part 37: Non-electrical equipment for explosive atmospheres - Non-electrical type of protection constructional safety "c", control of ignition sources "b", liquid immersion "k"

The standard above only applies to the extent that it is relevant for the purpose of the product. The product must not be used before the complete system, which it must be incorporated in, has been conformity assessed and found to comply with all relevant health and safety requirements of 2006/42/EC and other relevant directives. The product must be included in the overall risk assessment.

EU TYPE-Examination Certificate Number Ex type approval is under preparation  
Certification body Identification Number 2804

Viborg, 23.11.2022



Jan S. Christiansen – Manager, Technical dept.

Samson Pumps A/S | [www.samson-pumps.com](http://www.samson-pumps.com) | CVR.DK-27913695

DOC4050

## 1.2 Digital services

Samson Pumps offers a number of digital services to help our customers gain the best possible output from our products.

### Calculate



Solution Finder

### Buy



Product Center

### Learn



How to build

## 1.3 Foreword

This user manual applies to both ATEX and standard valves.

- 4way valve DN80 with pneumatic actuator
- 4way valve DN80 with handle bar
- 4way valve DN100 with pneumatic actuator
- 4way valve DN100 with handle bar
- 4way valve DN125 with pneumatic actuator
- 4way valve DN125 with handle bar

## 1.4 Explanation of warning symbols

Important technical and safety instructions is showed by symbols. If instructions are not performed correctly, it may lead to personnel injury or incorrect function of the 4-way valve.



To be used with all safety instructions that must be followed. A failure to follow the instructions may result in injuries and/or incorrect machine operation



This symbol stands for safety instructions which – if they are not observed – may lead to a risk of explosion. You must therefore always follow these instructions

## 1.5 ATEX Directive 2014/34/EU (ATEX approved only)

The 4way valve may be incorporated into a larger system, if the internal atmosphere has an area classification of Zone 0 and external atmosphere classification of Zone 1.

The 4way valve can also be implemented in other ATEX zones, except Zone 0 outside.

These systems must be certified in accordance with the ATEX Directive 2014/34/EU.

For the certification to be valid, the 4-way valve must be installed as described in this manual.

The 4way valve has explosion protection:



- II 1G Ex h IIC T4 Ga Internal
- II 2G Ex h IIC T4 Gb External

Explanation of symbols and characters used in ATEX marking:



The European Commission's mark for Ex products

- II** Equipment group II (non-mining)
- 1** Equipment category
- G** Type of explosive atmosphere (G = Gas)
- Ex** Indication of equipment for use in potentially explosive atmospheres
- h** Explosion protection
- IIC** Gas group (explosion group)
- T4** Temperature class (T4 = 135°C)
- Ga** Equipment protection level

## 1.6 Field of application



Inlet of foreign objects can damage the 4way valve.

The 4way valve may only be used with media that are not aggressive to the valves materials. See section 2.6 for components and appertaining materials. Equipment protection level

## 2 Technical data

### 2.1 Dimensions with pneumatic actuator

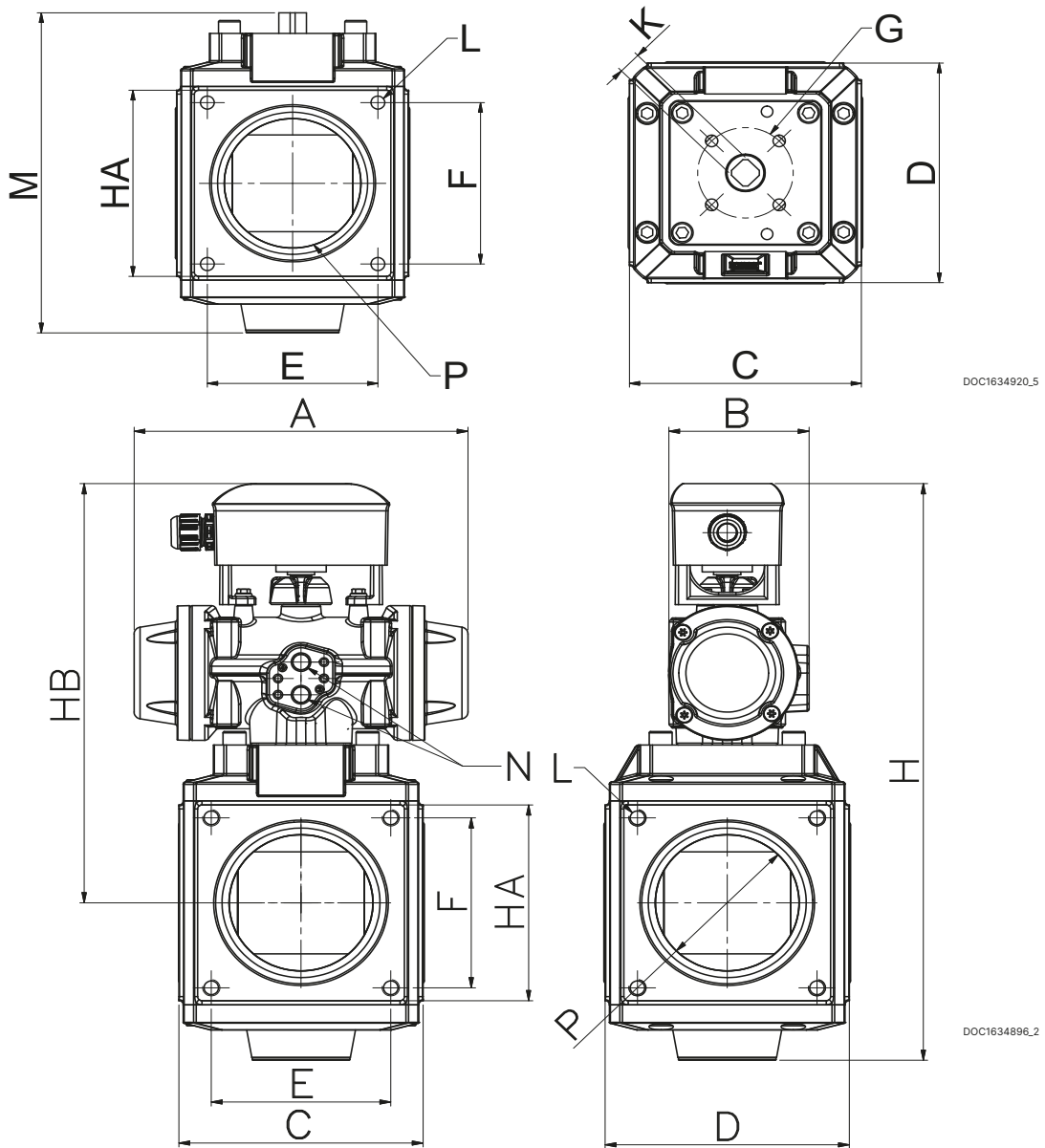

Model	Vehical internal pipe system	A	B	C	D	E	F	G	H	HA	HB	K	L	M	N	P	Weight [Kg]
DN80	3"	159	88	135	135	85	85	50	357	104	267	14	M10	203	¼"BSPP	75	13 / 14
DN100	4"	230	98	170	170	125	125	70	424	144	308	17	M12	248	¼"BSPP	100	24/26
DN125	5"	313	122	216	150	150	70	70	487	185	351	22	M12	289	¼"BSPP	125	43 / 46

2.2 Dimensions - With handle bar

DN80

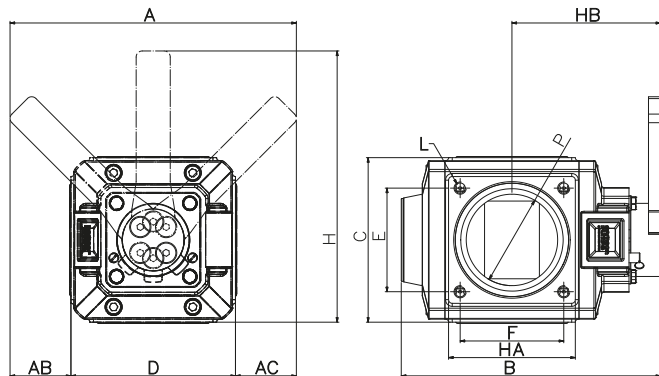

DN100

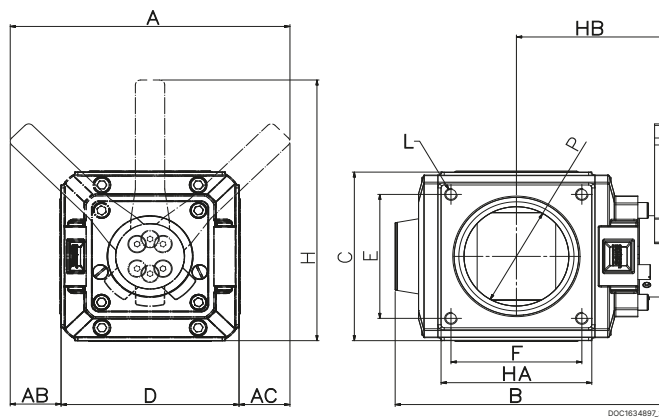

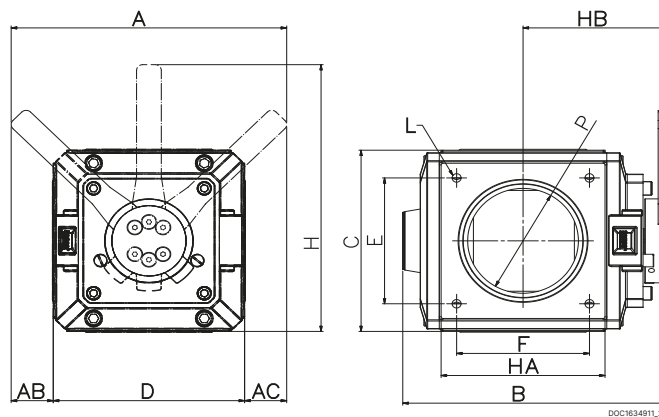

DN125



Model	Vehical internal pipe system	A	AB	AC	B	C	D	E	F	H	HA	HB	L	P	Weight [Kg]
DN80	3"	247	55	55	218	135	135	85	85	228	104	127	M10	75	14
DN100	4"	280	55	55	263	170	170	125	125	268	144	147	M12	100	25
DN125	5"	325	55	55	303	216	216	150	150	323	185	167	M12	125	44

### 2.3 Specifications

 A failure to meet these specifications may result in damage to the pump and a potential risk of explosion

 A failure to meet these specifications may result in damage to the 4way valve

Description	Min	Max
Ambient temperature, operation	-20°C	40°C
Ambient temperature, storage	-20°C	60°C
Working pressure	Full vacuum	3 bar(g)
Test pressure	Full vacuum	16 bar(g)
Pneumatic pressure	6 bar(g)	8 bar(g)

### 2.4 Operating the 4way valve

 The 4way valve may not used if damaged







The 4way valve must be inspected for damages upon delivery. If the 4way valve is damaged, it may not be used and the damage must be reported to the dealer.

### 2.5 Storage

After operation, the 4way valve can be stored without further action.

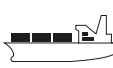
### 2.6 Handling and transport

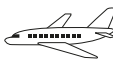
The 4way valve can be transported in the following ways:

Handling & transport	
Road	 
Sea	 
Air	 

DOC11093A

### 2.7 Materials

The 4way valve is composed by two main components:

- Pneumatic operated      Pos.1 & Pos.2
- Manually operated      Pos.1 & Pos.3

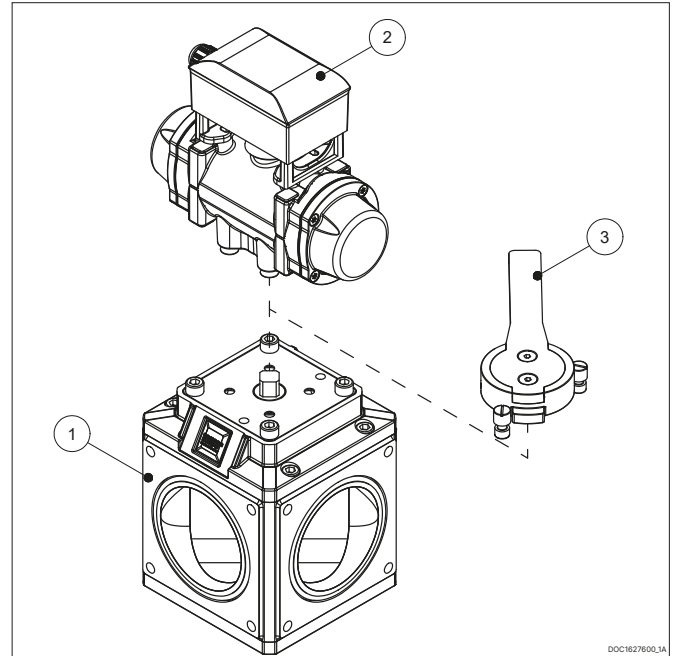

Term	Pos	Material
4way valve	1	Nickel coated cast iron
Actuator set	2	Plastic
Handle bar set	3	Stainless steel

### 2.8 4way valve parts

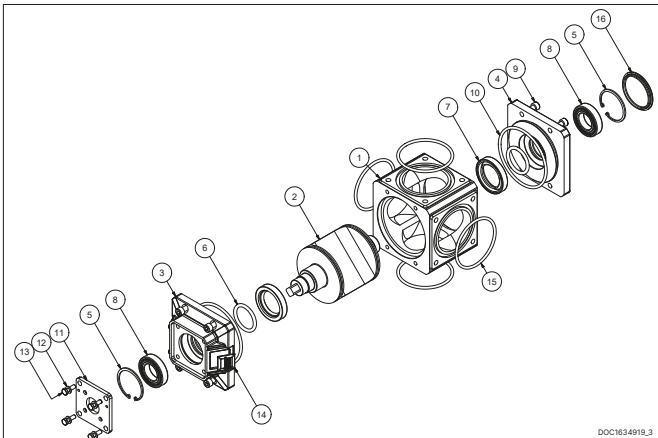

Pos	Part no	Description	Qty.
1	1634899	Valve body	1
2	1634901	Valve cone	1
3	1634903	Cover DE	1
4	1634906	Cover NDE	1
5	920000214	Locking ring	2
6	922100381	O-ring	2
7	922200271	Rotary Seal	2
8	930000321	Ball bearing	2
9	910300179	Screw	8
10	922100386	O-ring	2
11	1634905	Flange	1
12	910100125	Washer	4
13	910000392	Bolt	4
14	107989	Transfer domet	1
15	922100385	O-ring	4
16	948300065	End cap	1

### 2.9 Pneumatic actuator parts

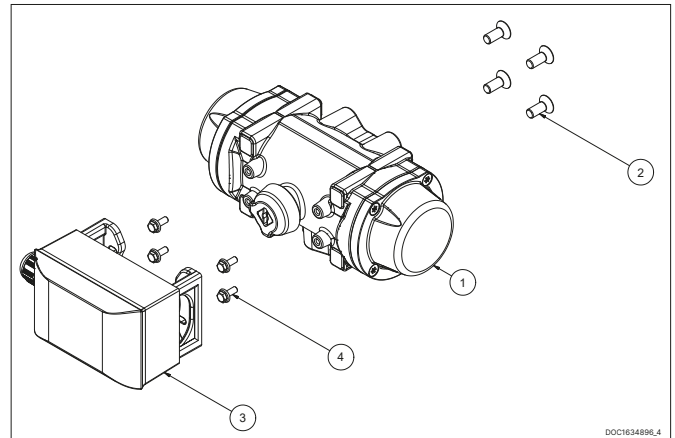

Pos	Part no	Description	Qty.
	944600332	Pneumatic actuator - DN80	1
1	944600333	Pneumatic actuator - DN100	1
	944600334	Pneumatic actuator - DN125	1
2	910300268	Screw DN80	4
	910000454	Screw DN100 - DN125	4
3	948000436	Feedback switch for actuator	1
4	910400230	Screw	4

## 3 Vehicle integration & installation

### 3.1 3-way pneumatic actuator positions

The actuator is assembled with a switch providing signals for suction, neutral and discharge position.

For air control its necessary to install a 5/3 way pneumatic operated valve as illustrated below. This valve can activate the actuator and turn it between suction and discharge. During this rotation, a signal for neutral position is given. If neutral position is requested its possible to stop the valve in this position simply by removing the signal to the valve.

It is important to mount needle valves on the supply line to the actuator - see illustration below. This will ensure higher accuracy in neutral position when the installation is with pneumatic hoses more than five meters long.

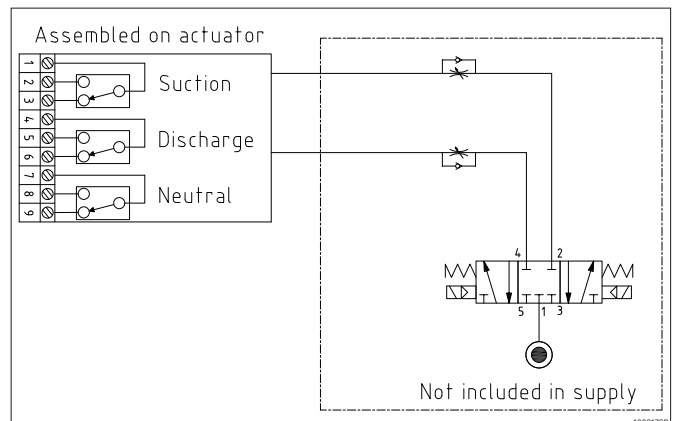



### 3.2 Adjusting the actuator positioning

The actuator is assembled with a positioning switch. The cams on the camshaft, in the positioning switch, are manually calibrated in order to get signals for suction, neutral and discharge positions. The valve cone position corresponds to the yellow marking on top of camshaft. See illustrations below. (Suction - Neutral - Discharge)

#### Suction

1. Turn the valve cone CCW to max position.
2. Push the lower cam of the camshaft and turn it CW until the lower micro switch is activated. Release the cam.

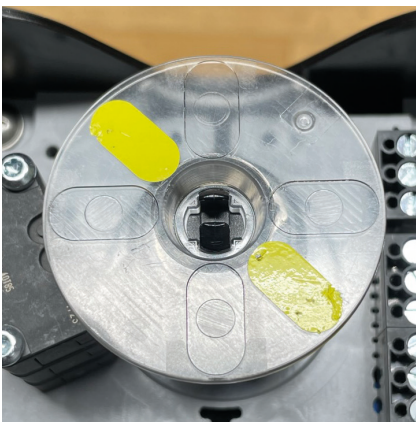

DOC11799

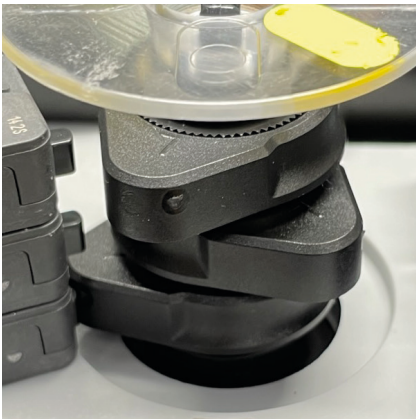

DOC11800



DOC11801

#### Neutral

3. Turn the valve cone CW until the valve cone is in the middle position. See middle illustration.
4. Push the upper cam of the camshaft and turn it CW until the upper micro switch is activated. Release the cam.

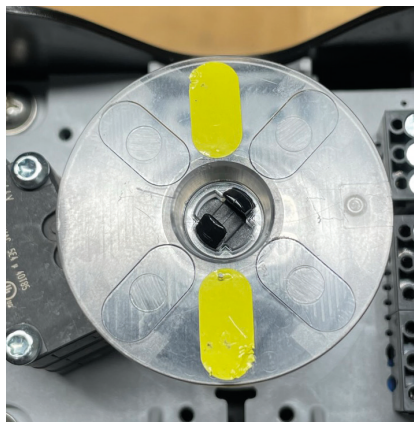

DOC11802

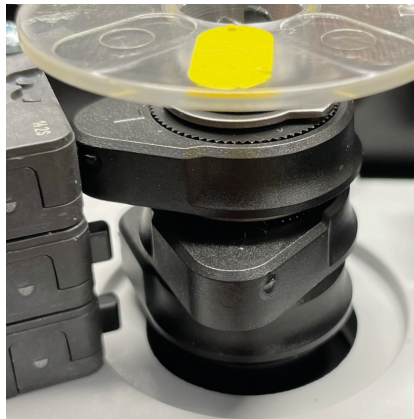

DOC11803

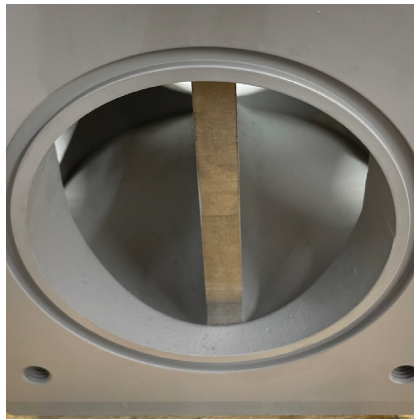

DOC11804

#### Discharge

5. Turn the valve cone CW until the valve cone is in the max position. See below right illustration.
6. Push the middle cam of the camshaft and turn it CW until the upper micro switch is activated. Release the cam.

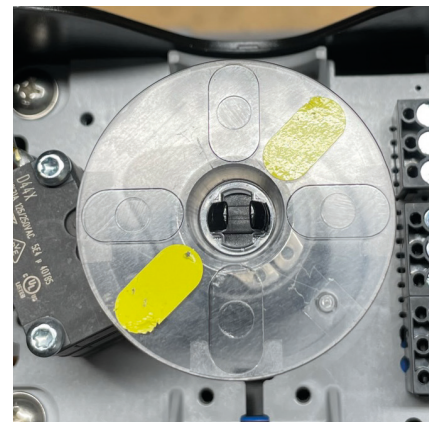

DOC11805



DOC11806



DOC11805

### 3.3 Positions - Pneumatic actuator

By connecting compressed air to connection 4 on the 4way valve. See below.

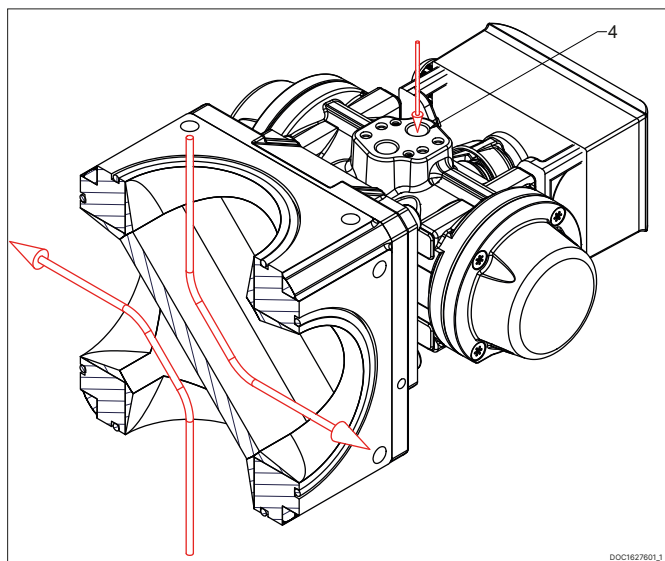

By connecting compressed air to connection 2 on the 4-way valve. See below.

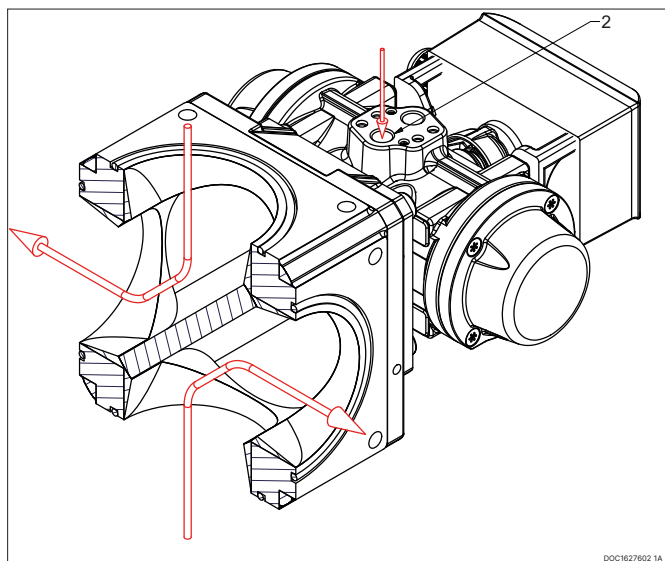

### 3.4 Positions - With handle bar

Position A achieved by turning the handle clockwise (CW). See below.

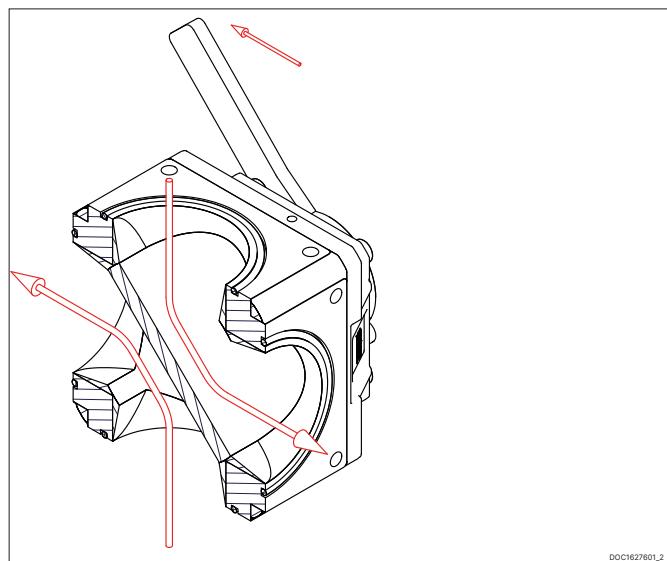

Position B achieved by turning the handle counter clockwise (CCW). See below.

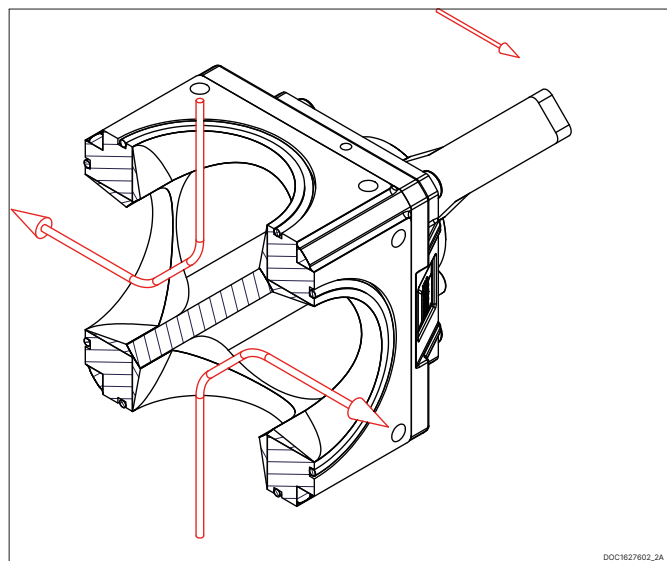

### 3.5 Placing the 4way valve

- The 4way valve must be installed with the valve spindle shaft horizontally. See illustration below. All horizontal positions are allowed.
- Do NOT install the 4way valve with the valve spindle shaft vertically. See illustration below. All vertical positions are prohibited.

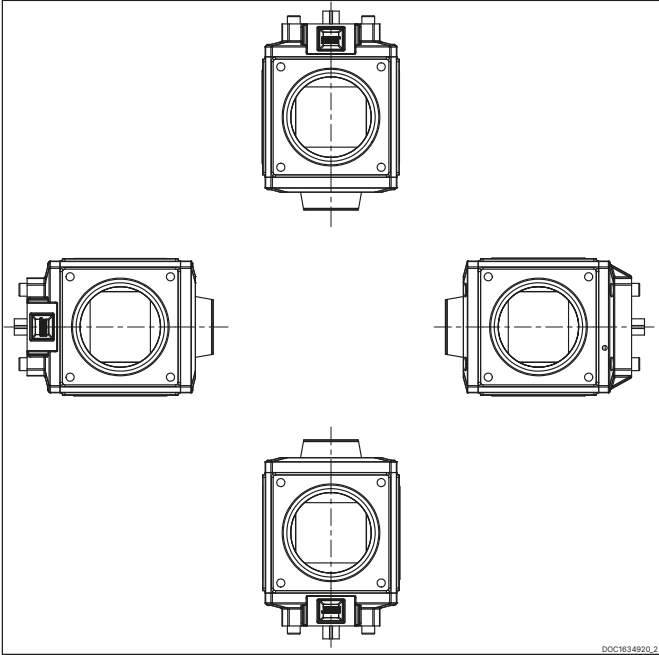

### 3.7 Flange connections

Deflection on the flanges from the welding process can affect the tolerances inside the valve and block the cones free rotation. Therefore its important to use machined flanges or alternatively use maximum 8 mm flanges. See below illustration.

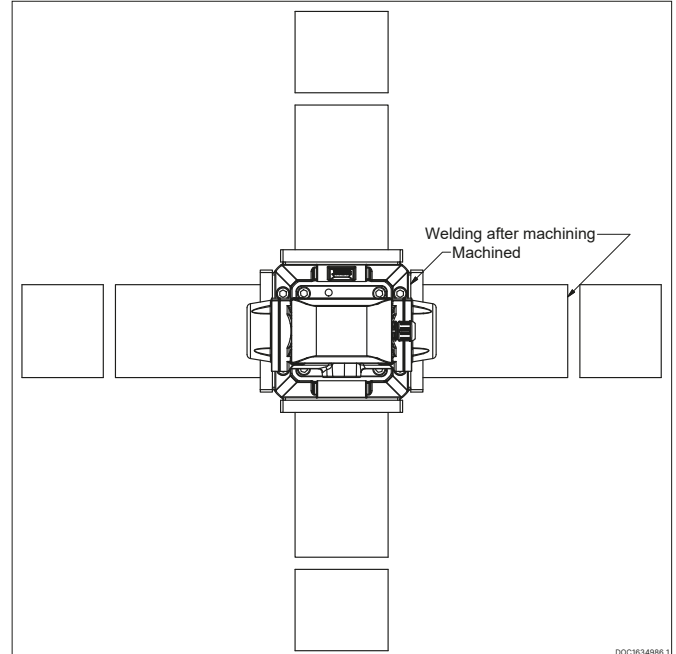

### 3.6 Securing the 4way valve

The following is primarily for when the valve is used in ATEX area.



External effects on the 4way valve may lead to leakage and, as a result, a potential risk of explosion. Foreign objects must not generate sparks.



- Gaskets to be handled with highest degree of caution.
- Gasket and sealing surfaces must be cleaned before assembly and without damage.
- If the tolerance for securing the 4way valve is not observed, there is a risk of damage and of potential explosion.
- Be aware of static electricity, the 4way valve must be grounded if necessary.
- Read Chapter 3.7

The 4way valve must be installed on a stable foundation, which must be level and stable, so that the 4way valve is not twisted or exposed to a  $\pm 0.1$  mm profile distortion.

Bolts must be tightened in accordance with supplier's instructions.

Ensure that the flow direction is correct before assembly.

The 4way valve's end stop can only be used as a stop when operating with manual handle bar. When activated with a cylinder, the cylinder's own end stop must be used.

## 4 Service, maintenance & inspection intervals



A failure to meet these specifications may result in damage to the 4way valve



A failure to observe the inspection intervals described in table below, may result in damage to the 4way valve and a potential risk of explosion.

Only qualified personnel may carry out repairs. The qualified person shall have the following knowledge:

- Knowledge of methods of protection. (For ATEX approved only)
- Knowledge of area classification. (For ATEX approved only)
- Knowledge of installation practices. (For ATEX approved only)

Repairs must be carried out according to manufacturer recommendations. If these are not followed, the ATEX declaration is not valid.

Use only original materials and components as described, during repair and maintenance.

During repair or disassembly, check that the flow direction remains unchanged.

For repair of the actuator, see accompanying supplier instructions.

Section	Operation	Interval	Category 1	Category 2
4.1	Visually inspect for leakage	Weekly	X	X
4.2	Inspection and cleaning (if necessary)	Monthly	X	X

### 4.1 Inspecting for leakage

The 4way valve and pipe system around, must be inspected for leakage once a week. The inspection must be performed when the 4way valve is both operating and idle. Any leaks must be repaired before operation may continue.

### 4.2 Inspection and cleaning

The pipe connections of 4way valves must be inspected at least once a month, and any contaminants must be removed. The 4way valve must always run easily and effortlessly, otherwise it must be cleaned.

## 4.3 Marking and identification

The 4way valve is equipped with an Serial No. as shown below.

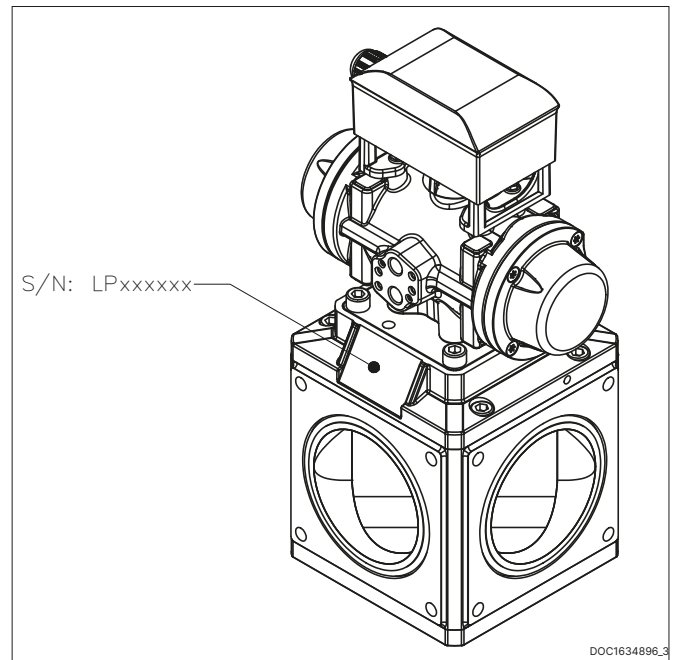

DOC1634896\_3