



Truck Master Series

INSTALLATION
OPERATION
MAINTENANCE

Non Ex

Zone 1 Internal / 1 External 

Zone 0 Internal / 1 External 



MODELS:
Truck Master 2
Truck Master 3
Truck Master 1700
Truck Master 2500
Truck Master 3400

Table of content

Page	Chapter	
3	1	Introduction
3	1.1	Declaration of Conformity
4	1.1.2	Declaration of Conformity Ex Zone 1/1
5	1.1.3	Declaration of Conformity Ex Zone 0/1
6	1.2	Digital services
6	1.3	Explanation of warning symbols
6	1.4	Field of application
6	1.5	Disposal
7	1.6	ATEX Directive 2014/34/EU 2014/34/EU
8	2	Technical data
8	2.1	Specifications metric
9	2.2	Specifications U.S. Imperial
10	2.3	Heat input for cooler calculation
10	2.4	Dimensions
11	2.5	Connections
12	2.6	Function of connections
15	2.7	Performance
16	2.8	Handling and transport
16	2.9	Storage and draining procedure
17	3	Design of a system
17	3.1	Drain in general
17	3.1.1	Drain for winterzation
17	3.1.2	Important actions when draining ATEX pumps
17	3.1.3	Drain procedures for water-tank
18	3.2	How to build a successful liquid ring vacuum truck
19	3.3	Air cooling with fan cooler - Metric
19	3.4	Fan cooler - Metric
21	3.5	Air cooling with fan cooler - U.S. Imperial
21	3.6	Fan cooler - U.S. Imperial
22	3.7	Water consumption - Metric
23	3.8	Water consumption - U.S. Imperial
23	3.9	Dome valve system
23	3.10	Priming of the pump
24	3.11	System layout (Zone 1/1)
25	3.12	System layout (Zone 0/1)
26	3.13	Safety Integrity Level (SIL) according IEC 61508
26	3.14	Water placemant
27	3.15	Water separator
27	3.16	Water requirement
27	3.17	Pipe system dimensioning
28	3.18	Cavitation
28	3.19	Suction filter
28	4	Installation and start-up
28	4.1	Securing the pump
29	4.2	Connection to the vehicle
29	4.3	Transmission
30	4.4	Earth connection requirements
30	4.5	Direction of rotation
30	4.6	Prior to start-up
31	5	Service operation and maintenance and inspection intervals
31	5.1	Inspection and lubrication of bearings
31	5.2	Visually Inspecting for leakage
32	5.3	Check grease cartridges (Category 2 pumps with grease cartridges)
32	5.4	Inspection of ATEX safety device
33	5.5	Inspection and cleaning of water supply pipe
33	5.6	Calibration of ATEX safety device
33	5.7	Overhaul of pump
33	5.8	Inspection and cleaning of internal channels
34	5.9	Winterization
34	6	Troubleshooting
34	7	Spare parts and tools
34	7.1	Spare parts
35	7.2	Marking and identification

1 Introduction

1.1 Declaration of Conformity



Declaration of Conformity

Annex IIA

Samson Pumps A/S

Petersmindevej 21

DK-8800 Viborg

Hereby declares that the following products:

Liquid ring pump

Truck Master 2, Truck Master 3, Truck Master 350, Truck Master 600, Truck Master 1600, Truck Master 1700, Truck Master 2500, Truck Master 3400, SLP 2100, SLP 2700, SLP 3100

Conforms to the directive:

Machinery Directive 2006/42/EC

I hereby declare that the liquid ring pumps are in conformity with the following harmonized standards:

DS/EN ISO 12100:2011

Safety of machinery - General principles for design - Risk assessment and risk reduction

DS/EN 1012-2 + A1:2009

Compressors and Pumps - Safety requirements - Part 2: Vacuum pumps

The standards above only apply to the extent that it is relevant for the purpose of the pump.

The product must not be used before the complete system, which it must be incorporated in, has been conformity assessed and found to comply with all relevant health and safety requirements of 2006/42/EC and other relevant directives. The product must be included in the overall risk assessment.

Viborg, 02.12.2020

Jan S. Christiansen – Manager, Technical dept.

Samson Pumps A/S | www.samson-pumps.com | CVR.DK-27913695

DOC4044C

1.1.2 Declaration of Conformity Ex Zone 1/1



Declaration of Conformity

Annex IIA

Samson Pumps A/S

Petersmindevej 21
DK-8800 Viborg

Hereby declares that the following products:

Liquid ring pump

**TM3400, TM2500, TM1700, TM1600, TM600, TM350, SLP2100, SLP2700,
SLP3100, OM1000, OM700, OM500, OM450, OM250**

Conforms to the following directives:

Machinery Directive 2006/42/EC
ATEX Directive 2014/34/EU

Explosion protection as follows on nameplate:

- ⚡ II 2G Ex h IIC T4 Gb Internal
- ⚡ II 2G Ex h IIC T4 Gb External

I hereby declare, that the machine are in conformity with the following harmonized standards:

DS/EN ISO 12100:2011	Safety of machinery - General principles for design - Risk assessment and risk reduction
DS/EN 1012-2 + A1:2009	Compressors and Pumps - Safety requirements - Part 2: Vacuum pumps
DS/EN 1127-1:2019	Explosive atmospheres - Explosion prevention and protection - part 1: Basic concepts and methodology
DS/EN ISO 80079-36:2016	Explosive atmospheres - Part 36: Non-electrical equipment for explosive atmospheres - Basic method and requirements
DS/EN ISO 80079-37:2016	Explosive atmospheres - Part 37: Non-electrical equipment for explosive atmospheres - Non-electrical type of protection constructional safety "c", control of ignition sources "b", liquid immersion "k"

The standard above only applies to the extent that it is relevant for the purpose of the pump.

The product must not be used before the complete system, which it must be incorporated in, has been conformity assessed and found to comply with all relevant health and safety requirements of 2006/42/EC and other relevant directives. The product must be included in the overall risk assessment.

ATEX Conformity Certificate Number **ExVeritas 19 ATEX 0582**

Viborg, 07.12.2020

Jan S. Christiansen – Manager, Technical dept.

1.1.3 Declaration of Conformity Ex Zone 0/1



Declaration of Conformity

Annex IIA

Samson Pumps A/S

Petersmindevej 21
DK-8800 Viborg

Hereby declares that the following products:

Liquid ring pump

TM3400, TM2500, TM1700, TM1600, TM600, TM350, SLP2100, SLP2700,
SLP3100

Conforms to the following directives:

Machinery Directive 2006/42/EC
ATEX Directive 2014/34/EU

Explosion protection as follows on nameplate:

- ⊕ II 1G Ex h IIC T4 Ga Internal
- ⊕ II 2G Ex h IIC T4 Gb External

I hereby declare, that the machine are in conformity with the following harmonized standards:

DS/EN ISO 12100:2011	Safety of machinery - General principles for design - Risk assessment and risk reduction
DS/EN 1012-2 + A1:2009	Compressors and Pumps - Safety requirements - Part 2: Vacuum pumps
DS/EN 1127-1:2019	Explosive atmospheres - Explosion prevention and protection - part 1: Basic concepts and methodology
DS/EN ISO 80079-36:2016	Explosive atmospheres - Part 36: Non-electrical equipment for explosive atmospheres - Basic method and requirements
DS/EN ISO 80079-37:2016	Explosive atmospheres - Part 37: Non-electrical equipment for explosive atmospheres - Non-electrical type of protection constructional safety "c", control of ignition sources "b", liquid immersion "k"

The standard above only applies to the extent that it is relevant for the purpose of the pump.

The product must not be used before the complete system, which it must be incorporated in, has been conformity assessed and found to comply with all relevant health and safety requirements of 2006/42/EC and other relevant directives. The product must be included in the overall risk assessment.

EU TYPE-Examination Certificate Number **ExVeritas 19 ATEX 0452X**
Certification body Identification Number **2804**

Viborg. 02.12.2020

Jan S. Christiansen – Manager, Technical dept.

1.2 Digital services

Samson Pumps offers a number of digital services to help our customers gain the best possible output from our products.

Calculate



Solution Finder

Buy



Product Center

Learn



How to build

1.3 Explanation of warning symbols

Important technical and safety instructions are shown by symbols. If the instructions are not performed correctly, it can lead to personnel injuries or incorrect function of the pump.



To be used with all safety instructions that must be followed. A failure to follow the instructions may result in injuries and/or incorrect machine operation



This symbol stands for safety instructions which – if they are not observed – may lead to a risk of explosion. You must therefore always follow these instructions



This symbol precedes information that refers to pumps used in a potentially explosive atmosphere and instructions related to Ex

1.4 Field of application



- Inlet of foreign objects can damage the pump
- The pump is designed exclusively to pump gases, including atmospheric air
- **WARNING!**
Avoid cavitation of the pump! For further information, see instruction manual for the Samson Pumps vacuum control valve (optional)

It must be ensured that the inlet gas cannot react with the water and create aggressive bonds that break down the pump's components.

For other operating data, see specifications.

The pump can only be used with media that is not aggressive to the pump's materials.

The pump may only be used with media that are not aggressive to the pump's materials. See section "Technical data" for pump materials specifications.

When using ATEX-approved pumps, refer to the marking on the pump and the areas of application specified in the ATEX Directive.

1.5 Disposal

Samson's liquid ring pump is manufactured so that most of the device can be reused/recycled.

Samson Pumps offer all users the option of returning used products to be restored or scrapped.

Alternatively, the pump must be taken apart and sorted into its separate components, by the customer. See section "Technical data" for pump materials specifications.

These components must be disposed of in accordance with national regulations.

1.6 ATEX Directive 2014/34/EU 2014/34/EU



Zone 1

This chapter relate to Ex Zone 1/1 approved pumps (ATEX category 2 pumps)

Zone 1 (for ATEX category 2 pumps)

The pump may be incorporated into a larger system, if the internal atmosphere has an area classification of:

Zone 1 (for ATEX category 2 pumps)

These systems will be certified in accordance with the ATEX Directive 2014/34/EU.

For the certification to be valid, the pump must be installed as described in this manual.



II 2G Ex h IIC T4 Gb Internal
II 2G Ex h IIC T4 Gb External

ExVeritas 19 ATEX 0582

Explanation of symbols and characters used in ATEX marking:



The European Commission's mark for Ex products

II	Equipment group II (non-mining)
2	Equipment category
G	Type of explosive atmosphere (G = Gas)
Ex	Indication of equipment for use in potentially explosive atmospheres
h	Explosion protection
IIC	Gas group (explosion group)
T4	Temperature class (T4 = 135 °C / 275 °F)
Gb	Equipment protection level



Zone 0

This chapter relate to Ex Zone 0/1 approved pumps (ATEX category 1 pumps)

Zone 0 (for ATEX category 1 pumps)

The pump may be incorporated into a larger system, if the internal atmosphere has an area classification of:

Zone 0 (for ATEX category 1 pumps)

These systems will be certified in accordance with the ATEX Directive 2014/34/EU

For the certification to be valid, the pump must be installed as described in this manual.



II 1G Ex h IIC T4 Ga Internal
II 2G Ex h IIC T4 Gb External

ExVeritas 19 ATEX 0452X

Explanation of symbols and characters used in ATEX marking:



The European Commission's mark for Ex products

II	Equipment group II (non-mining)
1	Equipment category
G	Type of explosive atmosphere (G = Gas)
Ex	Indication of equipment for use in potentially explosive atmospheres
h	Explosion protection
IIC	Gas group (explosion group)
T4	Temperature class (T4 = 135 °C / 275 °F)
Ga	Equipment protection level

ExVeritas 19 ATEX 0452X is the certificate number.

Special Conditions for Safe Use:

For pumps classified Ga (Zone 0), temperature monitoring is required on the bearings to initiate a shutdown of the equipment in case bearings exceed the temperature, listed under Section "System layout (Zone 0/1) in the Instruction Manual.

The temperature sensors must be connected to a monitoring and shutdown system which is sufficiently reliable and compliant with the requirements for ATEX safety related devices and systems as defined in Annex II, clause 1.5.1 of Directive 2014/34/EU (i.e. b1 (SIL1) as defined by EN ISO 80079-37 cl. 6.5).

Refer to manufacturer's Instruction Manual for correct installation and maintenance.

2 Technical data

2.1 Specifications metric



A failure to meet these specifications may result in damage to the pump



A failure to meet these specifications may result in damage to the pump and a potential risk of explosion

General specifications	Type	Truck Master 2	Truck Master 3	Truck Master 1700	Truck Master 2500	Truck Master 3400
Ambient temperature, operation MAX	-	55°C	55°C	55°C	55°C	55°C
Ambient temperature, storage MIN	-	-20°C	-20°C	-20°C	-20°C	-20°C
Humidity	-	100%	100%	100%	100%	100%
Intake temperature air, suction side MAX	Standard	NA	NA	NA	NA	NA
	1/1	80°C	80°C	80°C	80°C	80°C
	0/1	80°C	80°C	80°C	80°C	80°C
Intake temperature water, MAX	Standard	NA	NA	NA	NA	NA
	1/1	60°C	60°C	60°C	60°C	60°C
	0/1	60°C	60°C	60°C	60°C	60°C
Noise level @ 7m	-	63 db(A)	63 db(A)	63 db(A)	63 db(A)	63 db(A)
Noise level @ 1m	-	80 db(A)	80 db(A)	80 db(A)	80 db(A)	80 db(A)
Weight	-	68 kg	98 kg	245 kg	321 kg	531 kg
Water volume	-	13 L	32 L	49 L	84 L	104 L
Water pipe connection, dimension	-	G 1/2"	G 1/2"	G 3/4"	G 3/4"	G 1"
Water pipe connection max length	-	6m	6m	6m	6m	6m
MAX radial load on drive shaft	-	1400 N	2000 N	9000 N	7500 N	14000 N
Revolutions MAX	-	2000 RPM	1900 RPM	1800 RPM	1500 RPM	1400 RPM
Revolutions MIN	-	1100 RPM	1000 RPM	900 RPM	800 RPM	700 RPM
Pressure MAX	Standard	1 bar(g)	1 bar(g)	1 bar(g)	1 bar(g)	1 bar(g)
	1/1	1 bar(g)	1 bar(g)	1 bar(g)	1 bar(g)	0.75 bar(g)
	0/1	NA	NA	1 bar(g)	1 bar(g)	0.75 bar(g)
Pressure MIN	-	100 mbar abs.	100 mbar abs.	150 mbar abs.	150 mbar abs.	150 mbar abs.
Test pressure	-			12 bar(g)	12 bar(g)	12 bar(g)
Lubricating of bearings	Standard	Lifetime	Lifetime	Man/auto	Man/auto	Man/auto
	1/1	Lifetime	Lifetime	Man/auto	Man/auto	Man/auto
	0/1	Not available	Not available	Auto *	Auto *	Auto *
Grease type	Manual	NA	NA	SKF LGHQ2	SKF LGHQ2	SKF LGHQ2
	Automatic	NA	NA	SKF LAGD 125/HQ2	SKF LAGD 125/HQ2	SKF LAGD 125/HQ2
Casted parts	-	Aluminium	Aluminium	Cast iron	Cast iron	Cast iron
Rotor shaft	All	Stainless steel	Stainless steel	Stainless steel	Stainless steel	Stainless steel
Rotor	All	Aluminium	Aluminium	Stainless steel	Stainless steel	Stainless steel
Surface treatment	All	Hard anodized	Hard anodized	E-coat	E-coat	E-coat



Zone 0
This chapter relate to Ex Zone 0/1 approved pumps (ATEX category 1 pumps)

It is required to install water separator to ensure the pump is supplied as much water as needed.
See System layout Zone 0/1.

* - Automatic lubrication: Zone 0/1 - Requirement.

2.2 Specifications U.S. Imperial



A failure to meet these specifications may result in damage to the pump



A failure to meet these specifications may result in damage to the pump and a potential risk of explosion

General specifications	Type	Truck Master 2	Truck Master 3	Truck Master 1700	Truck Master 2500	Truck Master 3400
Ambient temperature, operation MAX	-	131°F	131°F	131°F	131°F	131°F
Ambient temperature, storage MIN	-	-4°F	-4°F	-4°F	-4°F	-4°F
Humidity	-	100%	100%	100%	100%	100%
Intake temperature air, suction side MAX	Standard	NA	NA	NA	NA	NA
	1/1	176°F	176°F	176°F	176°F	176°F
	0/1	176°F	176°F	176°F	176°F	176°F
Intake temperature water, MAX	Standard	NA	NA	NA	NA	NA
	1/1	140°F	140°F	140°F	140°F	140°F
	0/1	140°F	140°F	140°F	140°F	140°F
Noise level @ 23 ft	-	63 db(A)	63 db(A)	63 db(A)	63 db(A)	63 db(A)
Noise level @ 3.3 ft	-	80 db(A)	80 db(A)	80 db(A)	80 db(A)	80 db(A)
Weight	-	150 lb	216 lb	540 lb	708 lb	1171 lb
Water volume	-	3.4 US gal	8.5 US gal	12.9 US gal	22.2 US gal	27.5 gal
Water pipe connection, dimension	-	G 1/2"	G 1/2"	G 3/4"	G 3/4"	G 1"
Water pipe connection max length	-	20 ft	20 ft	20 ft	20 ft	20 ft
MAX radial load on drive shaft	-	314.7 lbf	449.6 lbf	2023.2 lbf	1686.1 lbf	3147.3 lbf
Revolutions MAX	-	2000 RPM	1900 RPM	1800 RPM	1500 RPM	1400 RPM
Revolutions MIN	-	1100 RPM	1000 RPM	900 RPM	800 RPM	700 RPM
Pressure MAX	Standard	14.5 PSI	14.5 PSI	14.5 PSI	14.5 PSI	14.5 PSI
	1/1	14.5 PSI	14.5 PSI	14.5 PSI	14.5 PSI	10.9 PSI
	0/1	NA	NA	14.5 PSI	14.5 PSI	10.9 PSI
Pressure MIN	-	27 inHg	27 inHg	25.5 inHg	25.5 inHg	25.5 inHg
Test pressure	-			174 PSI	174 PSI	174 PSI
Lubricating of bearings	Standard	Lifetime	Lifetime	Man/auto	Man/auto	Man/auto
	1/1	Lifetime	Lifetime	Man/auto	Man/auto	Man/auto
	0/1	Not available	Not available	Auto *	Auto *	Auto *
Grease type	Manual	NA	NA	SKF LGHQ2	SKF LGHQ2	SKF LGHQ2
	Automatic	NA	NA	SKF LAGD 125/HQ2	SKF LAGD 125/HQ2	SKF LAGD 125/HQ2
Casted parts	-	Aluminium	Aluminium	Cast iron	Cast iron	Cast iron
Rotor shaft	All	Stainless steel	Stainless steel	Stainless steel	Stainless steel	Stainless steel
Rotor	All	Aluminium	Aluminium	Stainless steel	Stainless steel	Stainless steel
Surface treatment	All	Hard anodized	Hard anodized	E-coat	E-coat	E-coat



Zone 0

This chapter relate to Ex Zone 0/1 approved pumps (ATEX category 1 pumps)

It is required to install water separator to ensure the pump is supplied as much water as needed.
See System layout Zone 0/1.

* - Automatic lubrication: Zone 0/1 - Requirement.

2.3 Heat input for cooler calculation

Heat input for cooler calculation	Truck Master 2	Truck Master 3	Truck Master 1700	Truck Master 2500	Truck Master 3400
700 RPM					23 kW / 30.8 hp
800 RPM				16 kW / 21.5 hp	26 kW / 34.9 hp
900 RPM			9 kW / 12.1 hp	20 kW / 26.8 hp	34 kW / 45.6 hp
1000 RPM		7 kW / 9.4 hp	12 kW / 16.1 hp	23 kW / 30.8 hp	38 kW / 50.9 hp
1100 RPM	5 kW / 6.7 hp	8 kW / 10.7 hp	14 kW / 18.8 hp	27 kW / 36.2 hp	48 kW / 64.4 hp
1200 RPM	6 kW / 8 hp	9 kW / 12.1 hp	16 kW / 21.5 hp	32 kW / 42.9 hp	58 kW / 77.8 hp
1300 RPM	6 kW / 8 hp	11 kW / 14.8 hp	19 kW / 25.5 hp	36 kW / 48.3 hp	66 kW / 88.5 hp
1400 RPM	7 kW / 9.4 hp	13 kW / 17.4 hp	21 kW / 28.2 hp	41 kW / 54.9 hp	78 kW / 104.6 hp
1500 RPM	8 kW / 10.7 hp	14 kW / 18.8 hp	25 kW / 33.5 hp	48 kW / 64.4 hp	
1600 RPM	9 kW / 12.1 hp	17 kW / 22.8 hp	29 kW / 38.9 hp		
1700 RPM	11 kW / 14.8 hp	18 kW / 24.1 hp	32 kW / 42.9 hp		
1800 RPM	12 kW / 16.1 hp	20 kW / 26.8 hp	36 kW / 48.3 hp		
1900 RPM	14 kW / 18.8 hp	24 kW / 32.2 hp			
2000 RPM	17 kW / 22.8 hp				

2.4 Dimensions

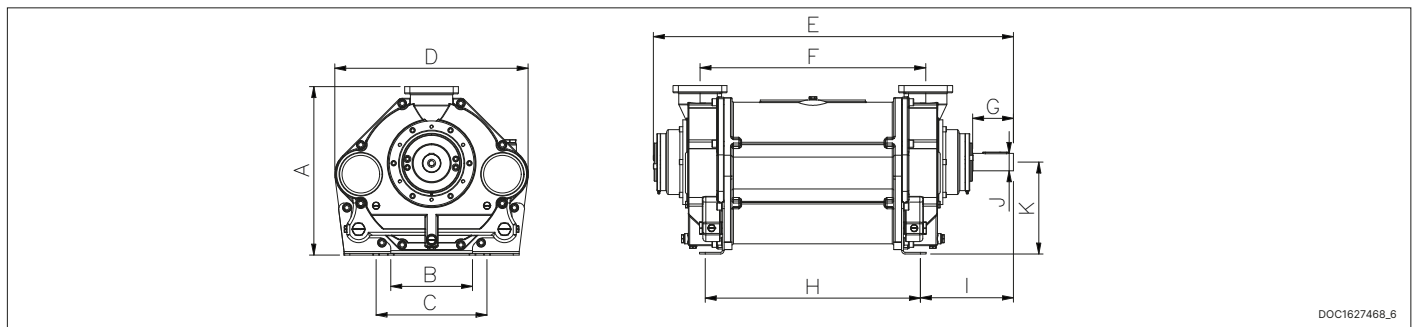
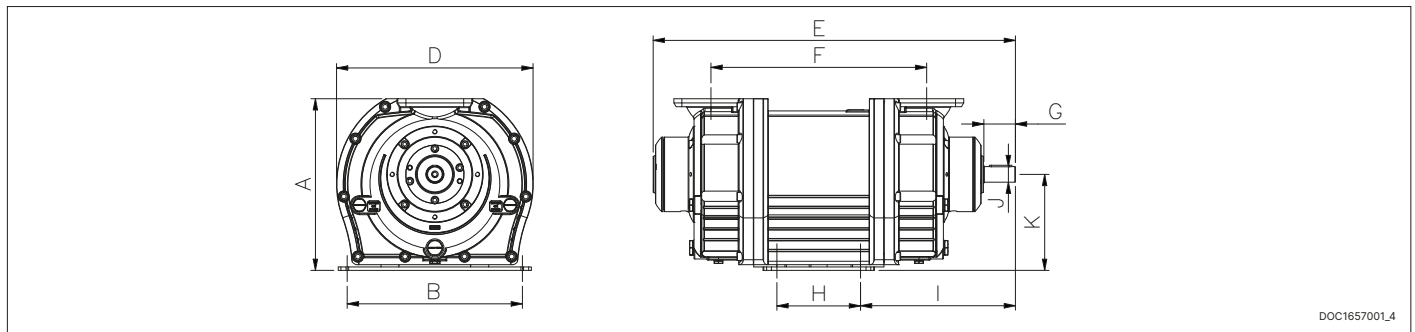

Model	A	B	C	D	E	F	G	H	I	J	K
Truck Master 2	348 mm / 13.7 in	342 mm / 13.5 in		382 mm / 15 in	644 mm / 25.4 in	335 mm / 13.2 in	70 mm / 2.8 in	102 mm / 4 in	306 mm / 12 in	Ø30 mm / 1.2 in	194 mm / 7.6 in
Truck Master 3	383 mm / 15.1 in	390 mm / 15.4 in		438 mm / 17.2 in	807 mm / 31.8 in	480 mm / 18.9 in	70 mm / 2.8 in	186 mm / 7.3 in	345 mm / 13.6 in	Ø35 mm / 1.4 in	214 mm / 8.4 in
Truck Master 1700	446 mm / 17.6 in	250 mm / 9.8 in	350 mm / 13.8 in	502 mm / 19.8 in	928 mm / 36.5 in	567 mm / 22.3 in	75 mm / 2.9 in	466 mm / 18.3 in	268 mm / 10.6 in	Ø45 mm / 1.8 in	240 mm / 9.4 in
Truck Master 2500	498 mm / 19.6 in	300 mm / 11.8 in	400 mm / 15.7 in	579 mm / 22.8 in	1074 mm / 42.3 in	648 mm / 25.5 in	100 mm / 3.9 in	549 mm / 21.6 in	312 mm / 12.3 in	Ø48 mm / 1.9 in	270 mm / 10.6 in
Truck Master 3400	578 mm / 22.8 in	280 mm / 11 in	380 mm / 14.9 in	663 mm / 26.1 in	1234 mm / 48.6 in	773 mm / 30.4 in	140 mm / 5.5 in	737 mm / 29 in	319 mm / 12.6 in	Ø60 mm / 2.4 in	315 mm / 12.4 in

2.5 Connections

Truck Master 2 - 3

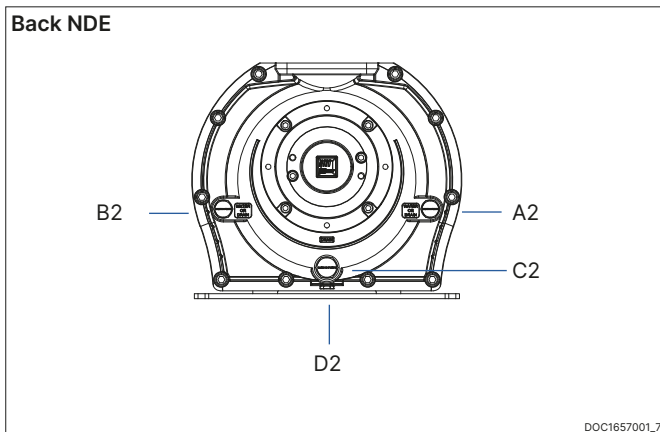
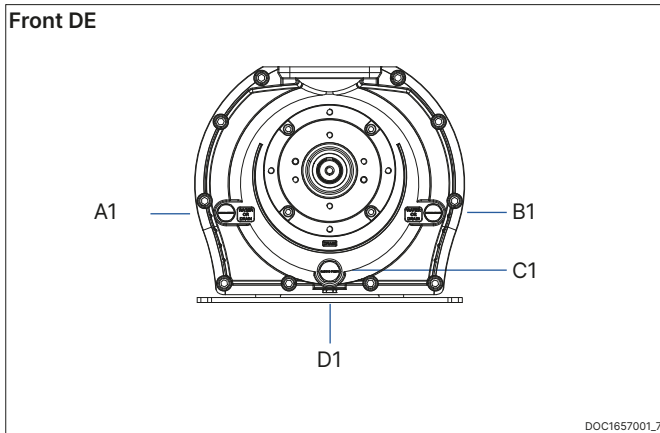

Connection ID & size	Truck Master 2	Truck Master 3
A1	G1/2"	G1/2"
A2	G1/2"	G1/2"
B1	G1/2"	G1/2"
B2	G1/2"	G1/2"
C1	G3/4"	G3/4"
C2	G3/4"	G3/4"
D1	G1/4"	G1/4"
D2	G1/4"	G1/4"

Truck Master 1700 - 2500 - 3400

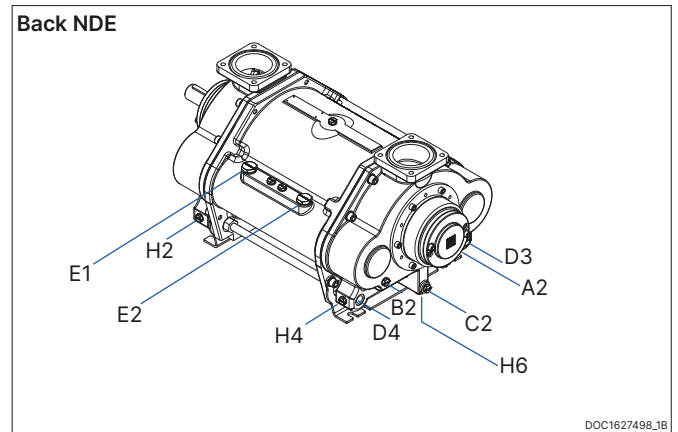
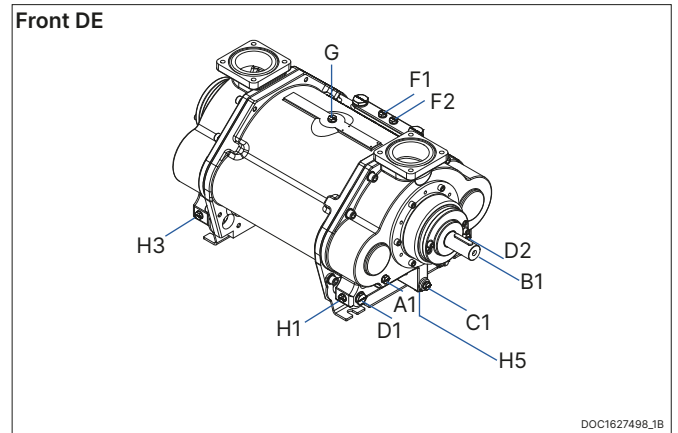

Connection ID & size	Truck Master 1700	Truck Master 2500	Truck Master 3400
A1, A2	G3/8"	G3/8"	G3/8"
B1, B2	G3/8"	G3/8"	G3/8"
C1, C2	G1/2"	G1/2"	G1/2"
D1, D2, D3, D4	G3/4"	G3/4"	G1"
E1, E2	G1"	G1"	G1"
F1, F2	G3/8"	G3/8"	G3/8"
G	G3/8"	G3/8"	G3/8"
H1, H2, H3, H4, H5, H6	G3/8"	G3/8"	G3/8"

2.6 Function of connections

Truck Master 2 - 3

C1	Plug
Function	Main drain
Winterization	Necessary to drain for winterization in cases where this plug is located lowest.

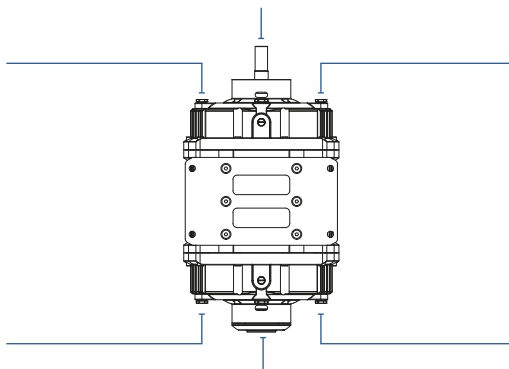

B1, B2	Plug
Function	Water supply if desired.
Winterization	Its necessary to drain one of the A or B connections for winterization. If the pump is angled, drain from the lowest located connection.

A1, A2	Plug
Function	Water supply if desired.
Winterization	Its necessary to drain one of the A or B connections for winterization. If the pump is angled, drain from the lowest located connection.

C2	Plug
Function	Main drain
Winterization	Necessary to drain for winterization in cases where this plug is located lowest.

DOC1657001_7

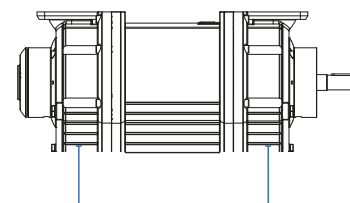

D1, D2	Plug
Function	No function
Winterization	NA

Flanges connections

Model	A	B	C
Truck Master 2	M10	Ø110 mm / 4.3 in	Ø55 mm / 2.2 in
Truck Master 3	M12	Ø160 mm / 6.3 in	Ø83 mm / 3.3 in

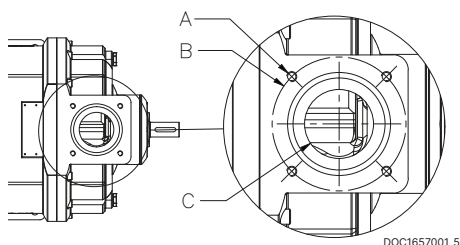

DOC1657001_5

Truck Master 1700 - 2500 - 3400

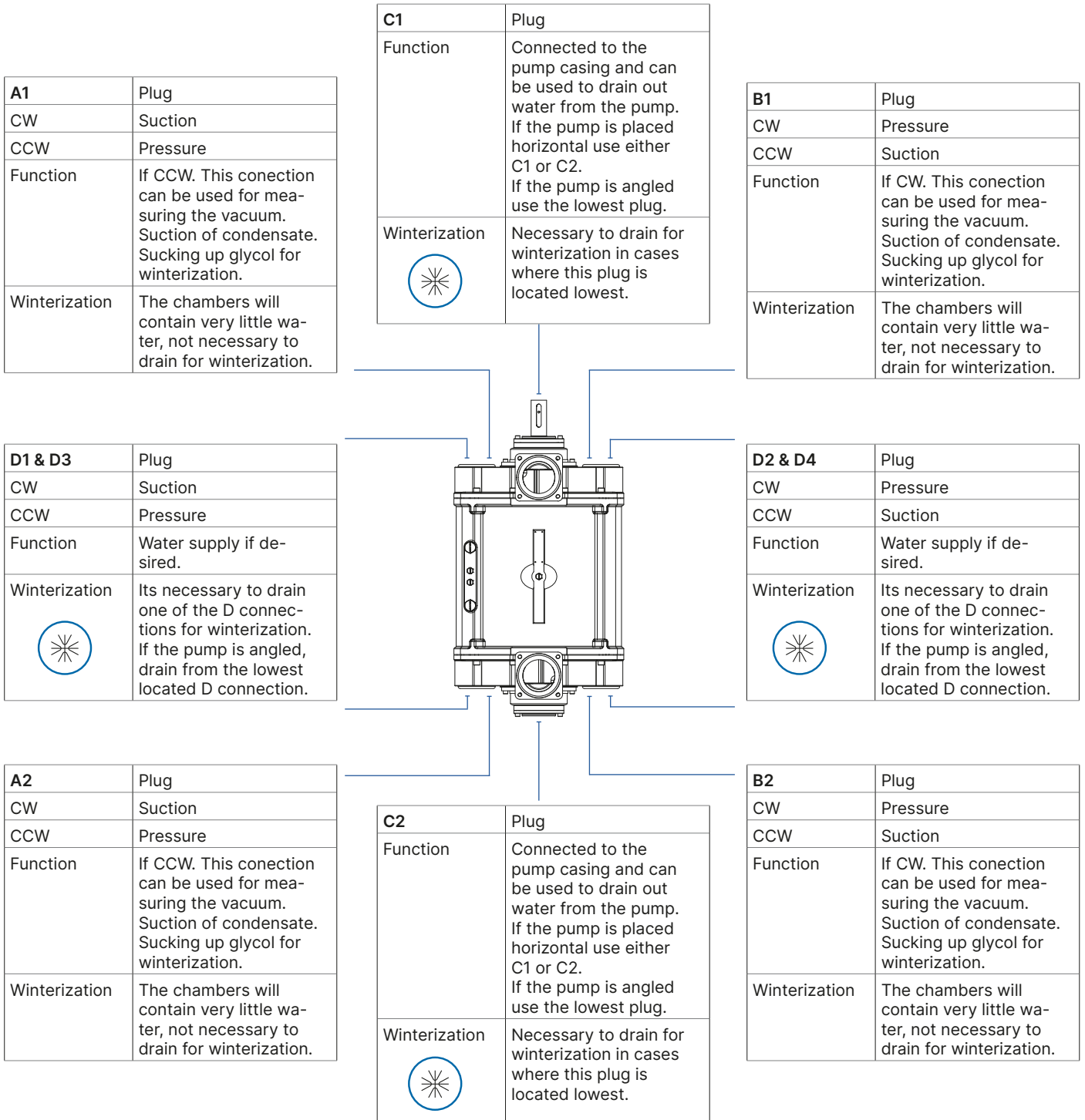

DOC1627468_B

F	Plug
CW	Right side, seen from shaft end
CCW	Left side seen from DE
Function	Pilot pressure for vacuum control valve
Winterization	NA

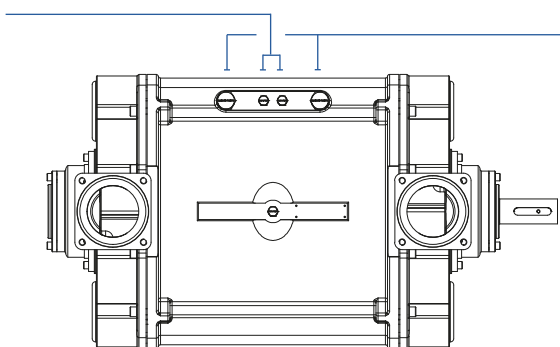

E	Plug
CW	Right side, seen from shaft end
CCW	Left side seen from DE
Function	Main connection for mounting vacuum control valve
Winterization	NA

H x 6	Plug
Function	No function
Winterization	NA

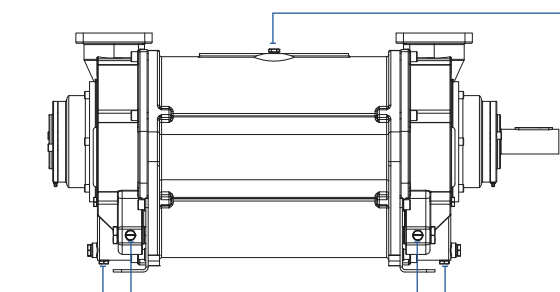

G	Plug
CW	Center
CCW	Center
Function	Pilot pressure for vacuum control valve
Winterization	NA

DOC1627468_8

Flanges connections

Model	A	B	C
Truck Master 1700	M16	Ø180 mm / 7.1 in	Ø107 mm / 4.2 in
Truck Master 2500	M16	Ø180 mm / 7.1 in	Ø107 mm / 4.2 in
Truck Master 3400	M16	Ø210 mm / 8.3 in	Ø125 mm / 4.9 in

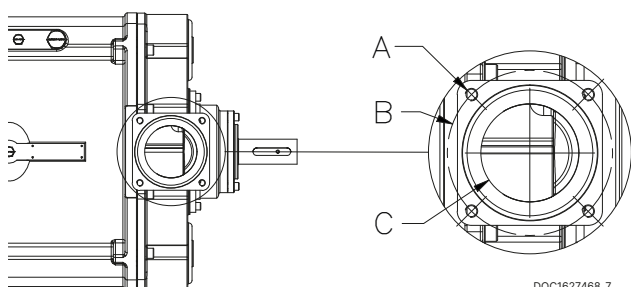

DOC1627468_7

2.7 Performance

To achieve the optimal performance and energy consumption, we recommend that the operator is able to adjust the RPM of the pump according to below schedule based on actual suction jobs. For more performance data please visit our Product Center at www.buy.samson-pumps.com

Truck Master 2			Vacuum-lift fluids	Air-lift fluids	Air-lift solids
	Suction hose 2"	Recommended	1200 RPM	1200 RPM	1700 RPM
	Suction hose 3"		1200 RPM	1600 RPM	1800 RPM
	Suction hose 4"		1200 RPM		
	Suction hose 5"		1200 RPM		
	Suction hose 6"		1200 RPM		

Truck Master 2 has its best performance in 2" suction hoses.

For suction hoses above 2" we recommend this pump for vacuum lifts of fluids only.

Truck Master 3			Vacuum-lift fluids	Air-lift fluids	Air-lift solids
	Suction hose 2"		1000 RPM	1000 RPM	1000 RPM
	Suction hose 3"	Recommended	1000 RPM	1100 RPM	1600 RPM
	Suction hose 4"		1000 RPM	1500 RPM	1800 RPM
	Suction hose 5"		1000 RPM		
	Suction hose 6"		1000 RPM		

Truck Master 3 has its best performance in 3" suction hoses and secondary in 2" with reduced RPMs.

For suction hoses above 3" we recommend this pump for vacuum lifts of fluids only.

Truck Master 1700			Vacuum-lift fluids	Air-lift fluids	Air-lift solids
	Suction hose 2"		900 RPM	900 RPM	900 RPM
	Suction hose 3"		900 RPM	900 RPM	900 RPM
	Suction hose 4"	Recommended	900 RPM	1500 RPM	1800 RPM
	Suction hose 5"		900 RPM	1800 RPM	
	Suction hose 6"		900 RPM		

Truck Master 1700 has its best performance in 4" suction hoses and secondary in 2" and 3" with reduced RPMs.

For suction hoses above 4" we recommend this pump for vacuum lifts of fluids only.

Truck Master 2500			Vacuum-lift fluids	Air-lift fluids	Air-lift solids
	Suction hose 2"		800 RPM	800 RPM	800 RPM
	Suction hose 3"		800 RPM	800 RPM	800 RPM
	Suction hose 4"		800 RPM	900 RPM	1100 RPM
	Suction hose 5"	Recommended	800 RPM	1300 RPM	1500 RPM
	Suction hose 6"		800 RPM	1500 RPM	

Truck Master 2500 has its best performance in 5" suction hoses and secondary in 3" and 4" with reduced RPMs.

For suction hoses above 5" we recommend this pump for vacuum lifts of fluids only.

Truck Master 3400			Vacuum-lift fluids	Air-lift fluids	Air-lift solids
	Suction hose 2"		600 RPM	600 RPM	600 RPM
	Suction hose 3"		600 RPM	600 RPM	1600 RPM
	Suction hose 4"		600 RPM	600 RPM	600 RPM
	Suction hose 5"		600 RPM	600 RPM	600 RPM
	Suction hose 6"	Recommended	600 RPM	1200 RPM	1400 RPM

Truck Master 3400 has its best performance in 6" suction hoses and secondary in 4" and 5" with reduced RPMs.

For suction hoses above 6" we recommend this pump for vacuum lifts of fluids only.

2.8 Handling and transport











A failure to meet these specifications may result in damage to the pump

The pump must be transported in such way that it is not exposed to vibrations and impacts that can overload the bearings.

The pump must be inspected for damages upon delivery. If the pump is damaged, it must not be used, and the damage must be reported to the manufacturer.

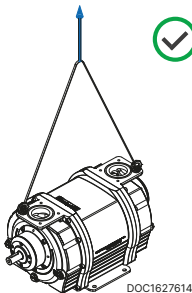
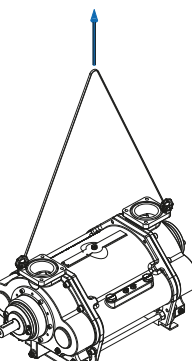
Ensure that the pump's identification plate is intact and that the marking of the pump corresponds to its use. The pump must only be handled using approved lifting eyes, in accordance with nationally applicable regulations and only in a vertical motion.

Handling & transport		DOC11093A
Road		
Sea		
Air		
Crane	 	

The pump must only be lifted using approved eye bolts in accordance with nationally applicable regulations and only in a vertical motion.

DOC1627614

DOC1627499A

2.9 Storage and draining procedure



A failure to comply with the requirements for storing the pump may result in internal damage to the device



If the temperature is below freezing point of the water, it could damage the pump. Under these conditions, the pump must be drained completely



All plugs and protective covers must be fitted during storage

The pump's water is drained on delivery, and the pump can be immediately stored in accordance with the technical specifications. After operation, the pump can be stored for 30 days without further action. If the pump remains out of operation for a longer period of time after use, its water must be drained, and the water supply to the pump must be shut off.

Draining during normal operation, see chapter Service operation and maintenance and inspection intervals.

Drain before storage	Action
Truck Master 2	Remove one A, B and C plug.
Truck Master 3	Remove one A, B and C plug.
Truck Master 1700	Remove one A, B, C and D plug.
Truck Master 2500	Remove one A, B, C and D plug.
Truck Master 3400	Remove one A, B, C and D plug.

3 Design of a system

3.1 Drain in general

 A failure to meet these specifications may result in damage to the pump

Below fig. is the recommended general procedures for draining the pump.

Drain schedule		
Vehicle operating environment	Purpose	Frequency
Above 0°C / 32°F	Drain to clean out dirt from the pump	As required
Below 0°C / 32°F	Winterization! Drain to prevent freezing of the service water	Before every non-operation period
Storage	Drain to protect the pump during storage	Before storage

3.1.1 Drain for winterzation

 A failure to meet these specifications may result in damage to the pump

Follow the instructions for each connection in chapter "Function of connections" marked with:

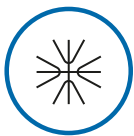

3.1.2 Important actions when draining ATEX pumps

 When operating the drain valves, the outlet may contain explosive gases, corresponding to the classification of the pump's suction side

 **Zone 1**
This chapter relate to Ex Zone 1/1 approved pumps (ATEX category 2 pumps)

After draining, make sure that Zone 1/1 pumps are primed before start up.

 **Zone 0**
This chapter relate to Ex Zone 0/1 approved pumps (ATEX category 1 pumps)

It is recommended to equip the pump with a drain valve pos 16 according to System layout (Zone 0/1). The valve must be activated from the control panel with the following control philosophy.

- The drain valve must be installed in connection C1 or C2
- Activation of the valve must only be possible when the pump is stopped.
- When the draining procedure is activated the drain valve will be open for 60 seconds. After this interval the drain valve will close.
- Any start of the pump after draining must activate a priming sequence according to chapter "Priming of the pump".

After draining, make sure that Zone 0/1 pumps are primed before start up.

3.1.3 Drain procedures for water-tank

 **Zone 0**
This chapter relate to Ex Zone 0/1 approved pumps (ATEX category 1 pumps)

The water separator must be drained to prevent accumulation of impurities in the tank, and most importantly, to maintain a healthy and non-aggressive water quality. The water must be drained out at regular intervals, see chapter "Service operation and maintenance and inspection intervals".

3.2 How to build a successful liquid ring vacuum truck

Dimensioning the vacuum system for a vehicle is essential for its performance in operation and as an investment. This is the Samson Pumps, step by step guide, of how to build a successful liquid ring vacuum truck.

You can also find a web version at:

<https://www.samson-pumps.com/how-to-build-your-system/>

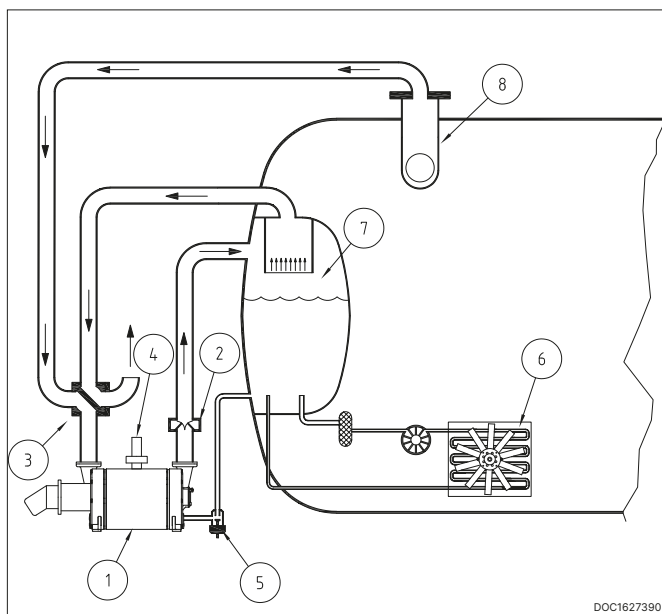

Pos	Description
1	Liquid ring pump
2	Non return valve
3	4-way valve
4	Vacuum control valve
5	Water control valve
6	Fan cooler
7	Water separator
8	Dome valve

Together with the air there will be a water flow out of the pump up to 6 m³/h / 3.5 cfm.

The water will be separated from the air in the water separator. Depending of the size of particles, water will be carried with the water when the air velocity is more than 3-4 m/s / 9.8-13.1 f/s.

The inlet speed to the separator can be more than 50 m/s / 164 f/s and this must be reduced to 3 m/s / 9.8 f/s. Below you find an illustration showing how to reduce the speed and control that no water will be in contact with the high velocity air stream. The round velocity reducer can be placed inside any tank geometry.

$\varnothing D$ so the velocity is below 3 m/s / 9.8 f/s.
 $H=4$ to $6 \cdot \varnothing d$ depending on the geometry. A smooth diameter conversion will give a low factor.

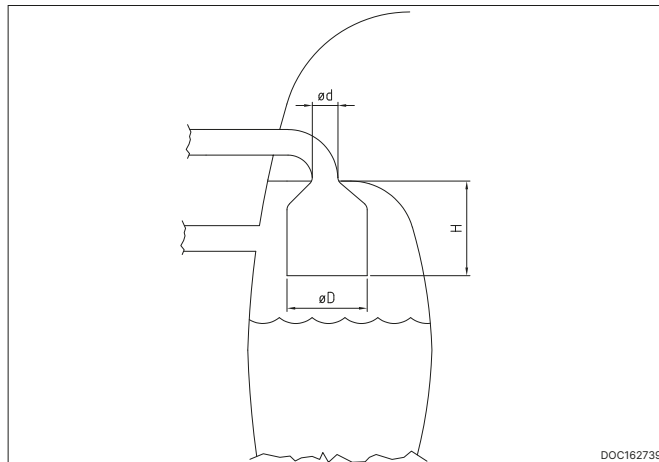

Air flow		$\varnothing D$ MIN	
[m ³ /h]	[cfm]	[mm]	[in]
3400	2001.2	600	23.6
3300	1942.3	590	23.2
3200	1883.4	580	22.8
3100	1824.6	570	22.4
3000	1765.7	560	22
2900	1706.9	550	21.7
2800	1648	575	22.6
2700	1589.2	565	22.2
2600	1530.3	555	21.9
2500	1471.4	545	21.5
2400	1412.6	530	20.9
2300	1353.7	525	20.7
2200	1294.9	510	20.1
2100	1236	500	19.7
2000	1177.2	490	19.3
1900	1118.3	475	18.7
1800	1059.4	460	18.1
1700	1000.6	450	17.7
1600	941.7	435	17.1
1500	882.9	420	16.5
1400	824	410	16.1
1300	765.2	390	15.4
1200	706.3	375	14.8
1100	647.4	360	14.2
1000	588.6	345	13.6
900	529.7	325	12.8
800	470.9	310	12.2
700	412	285	11.2
600	353.1	265	10.4
500	294.3	245	9.6
400	235.4	220	8.7
300	176.6	190	7.5

3.3 Air cooling with fan cooler - Metric

Compression of air inside the liquid ring pump will create heat that is transferred to the water. Therefore, it can be necessary to install a fan cooler depending on the expected use, the climate etc. The time it takes to heat up the water also depends on for example ambient temperature, suction pressure, amount of water and the cooling effect in the truck itself. The operation temperature will go up until there is a balance between the heat input and the heat output. So basically, there are only two things that can lower the operation temperature. Reduce the heat input or increase the heat output. The amount of water has no or only a little influence on the final operating temperature. The truck itself will work as a big radiator and if there is a huge amount of water in the liquid separator and thereby good contact area between the water and the steel tank, it will give a higher cooling effect. This in combination with low ambient temperature and short time of operation, could mean that the truck can operate without any additional cooling.

In general, the time it takes to heat up the water can be calculated from the formula below.

$$t_{\text{sec}} = \frac{C_p \times m \times \Delta t}{Q}$$

t_{sec}	Time in seconds
C_p	Heat capacity of the media. Water= 4.2
Δt	Temperature difference
m	Mass of the media heating up [Kg]
Q	Heat input in [kW] See specifications, chapter 2.2

Example:
We have a tank with 300 litres of water corresponding to 300 kg. The heat input is 30 kW.
How long will it take to heat it up from 20°C to 40°C ?

$$t_{\text{sec}} = \frac{4.2 \times 300 \times 20}{30} = 840 \text{ s} = \underline{14 \text{ min}}$$

The temperature will continue to go up until the steel construction can absorb the heat and transfer it to the surroundings.

With a temperature difference on 20°C it is typical to have a radiator effect in a truck on somewhere between 5 to 20 kW depending on the construction.

The table below shows truck radiator effect at a temperature difference of 20°C.

5 kW	Small liquid separator mounted external from the truck tank Water content below 100 L
10 kW	Small liquid separator inside slurry tank. Located with only minor contact to the product Water content 300 L
20 kW	Normal liquid separator inside slurry tank with good contact to the product Water content 400 L

3.4 Fan cooler - Metric

The fan cooler will increase the heat output from the construction and thereby stabilize the temperature at a lower level. However, this cooler will use the air to cool down the water and therefore we will always see that the temperature will be stabilized above the ambient temperature. It's very simple to find the right cooler based on the curves from the cooler manufacturer. Typically you will find the cooler capacity as kW/ Δt meaning for example 1.5 kW cooler capacity each °C in temperature difference between the water and the air. Note that the water flow through the cooler will also affect the cooling capacity.

Typical fan cooler characteristic

DOC1627392

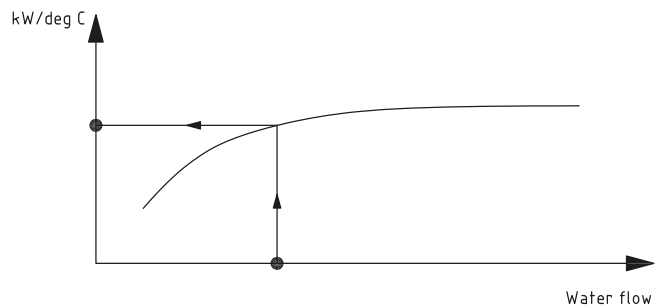

Practical calculation example:

The truck is used mostly to work with an operation pressure around 70% vacuum. From the technical data sheet, we find the heat input from the pump to be 68 kW. The liquid separator is built inside the slurry tank with a good contact to the product and a radiator effect estimated to 20 kW with a temperature difference of 20°C. The truck will work with ambient temperature up to 28°C during the summer and we will accept a maximum temperature on 40°C. First, we have to reduce the radiator effect based on a temperature difference of 12°C.

$$Q_{\text{out Truck}} = 20 \times \frac{12}{20} = 12 \text{ kW}$$

The total cooling effect required is thereby:

$$Q_{\text{out Pump}} - Q_{\text{out Truck}} = 68 - 12 = \underline{56 \text{ kW}}$$

Summary

Pump model	Description	
Heat input from technical specifications	$Q_{in Pump}$	
Ambient temperature	t_{amb}	28°C
Maximum Working Temperature of the water. This is determined by you. The temperature has influence on the pump performance	t_{op}	40°C
Temperature difference	Δ_t	$t_{Op} - t_{amb} = 12^\circ C$
Truck radiator effect based on 20 °C in temperature difference	$Q_{out Truck 20}$	20 kW
Truck radiator effect based on 12 °C in temperature difference	$Q_{out Truck 12}$	$12/20 * 20 = 12 \text{ kW}$
Total cooling requirement from fan cooler	$Q_{fan cooler}$	$Q_{in Pump} - Q_{out Truck 12} = 68 - 12 = 56 \text{ kW}$

We need to find a fan cooler that can transfer 56 kW with a temperature difference on 12°C. That is 4.6 kW/°C.

If we for example accept a higher temperature, for instance 48°C, we will have full cooling effect from the truck on 20 kW and a cooling requirement on 48 kW. The fan cooler we need to find is thereby on $48/20 = 2.4 \text{ kW/}^\circ C$ and a big difference to the bigger model calculated above.

3.5 Air cooling with fan cooler - U.S. Imperial

Compression of air inside the liquid ring pump will create heat that is transferred to the water. Therefore, it can be necessary to install a fan cooler depending on the expected use, the climate etc. The time it takes to heat up the water also depends on for example ambient temperature, suction pressure, amount of water and the cooling effect in the truck itself. The operation temperature will go up until there is a balance between the heat input and the heat output. So basically, there are only two things that can lower the operation temperature. Reduce the heat input or increase the heat output. The amount of water has no or only a little influence on the final operating temperature. The truck itself will work as a big radiator and if there is a huge amount of water in the liquid separator and thereby good contact area between the water and the steel tank, it will give a higher cooling effect. This in combination with low ambient temperature and short time of operation, could mean that the truck can operate without any additional cooling.

In general, the time it takes to heat up the water can be calculated from the formula below.

$$t_{sec} = \frac{C_p \times m \times \Delta t}{Q}$$

t_{sec}	Time in seconds
C_p	Heat capacity of the media. Water= 4.2 / 1.001
Δt	Temperature difference
m	Mass of the media heating up [lbs]
Q	Heat input in [kW] See specifications, chapter 2.2 [BTU]

Example:
We have a tank with 79 gallons of water corresponding to 661.4 pounds. The heat input is 28.4 BTU.
How long will it take to heat it up from 68°F to 104°F ?

$$t_{sec} = \frac{1.001 \times 79.3 \times 36}{28.4} = 840 \text{ s} = \underline{14 \text{ min}}$$

The temperature will continue to go up until the steel construction can absorb the heat and transfer it to the surroundings.

With a temperature difference on 68°F it is typical to have a radiator effect in a truck on somewhere between 4,7 BTU to 18,9 BTU depending on the construction.

The table below shows truck radiator effect at a temperature difference of 68°F.

4.7 BTU	Small liquid separator mounted external from the truck tank Water content below 26 gal
9.5 BTU	Small liquid separator inside slurry tank. Located with only minor contact to the product Water content 79 gal
18.9 BTU	Normal liquid separator inside slurry tank with good contact to the product Water content 106 gal

3.6 Fan cooler - U.S. Imperial

The fan cooler will increase the heat output from the construction and thereby stabilize the temperature at a lower level. However, this cooler will use the air to cool down the water and therefore we will always see that the temperature will be stabilized above the ambient temperature. It's very simple to find the right cooler based on the curves from the cooler manufacturer. Typically you will find the cooler capacity as kW/ Δt meaning for example 1.4 BTU cooler capacity each °F in temperature difference between the water and the air. Note that the water flow through the cooler will also affect the cooling capacity.

Typical fan cooler characteristic

DOC1627392

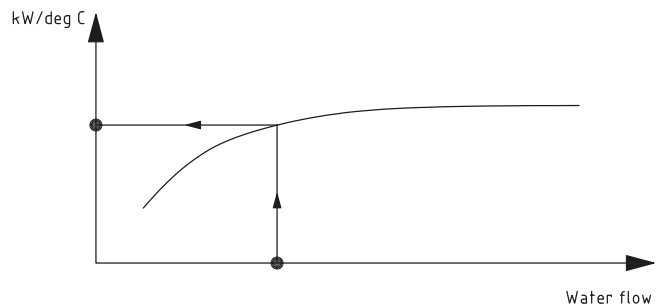

Practical calculation example:

The truck is used mostly to work with an operation pressure around 70% vacuum. From the technical data sheet, we find the heat input from the pump to be 64.5 BTU. The liquid separator is built inside the slurry tank with a good contact to the product and a radiator effect estimated to 19 BTU with a temperature difference of 36°F. The truck will work with ambient temperature up to 82°F during the summer and we will accept a maximum temperature on 104°F. First, we have to reduce the radiator effect based on a temperature difference of 22°F.

$$Q_{out \text{ Truck}} = 19 \times \frac{22}{36} = 11.6 \text{ BTU}$$

The total cooling effect required is thereby:

$$Q_{out \text{ Pump}} - Q_{out \text{ Truck}} = 64.5 - 11.6 = \underline{53 \text{ BTU}}$$

Summary

Pump model	Description	
Heat input from technical specifications	$Q_{in Pump}$	
Ambient temperature	t_{amb}	82°F
Maximum Working Temperature of the water. This is determined by you. The temperature has influence on the pump performance	t_{op}	104°F
Temperature difference	Δ_t	$t_{Op} - t_{amb} = 22^\circ F$
Truck radiator effect based on 36°F in temperature difference	$Q_{out Truck 20}$	18.9 BTU
Truck radiator effect based on 22°F in temperature difference	$Q_{out Truck 12}$	$22/36 \cdot 19 = 11.6$ BTU
Total cooling requirement from fan cooler	$Q_{fan cooler}$	$Q_{in Pump} - Q_{out Truck 12} = 64.5 - 11.6 = 53$ BTU

We need to find a fan cooler that can transfer 53 BTU with a temperature difference on 22°F. That is 2.4 BTU/°F.

If we for example accept a higher temperature, for instance 118°F, we will have full cooling effect from the truck on 18,9 BTU and a cooling requirement on 45.5 BTU. The fan cooler we need to find is thereby on $45.5/18.9 = 2.4$ BTU/°F and a big difference to the bigger model calculated above.

3.7 Water consumption - Metric

It is possible to design the liquid separator so that almost 100% of the water is separated from the air.

However, the air will be heated up and thereby it can content more water. Also, the relative humidity will go up and end near 100%.

So, the air will flow into the pump with maybe 50% relative humidity at a low temperature and be discharged at a higher temperature and humidity. Therefore, there will be an evaporation from the system.

Truck Master 2						
Vacuum	Temp	Choose your water temperature				
		20°C	30°C	40°C	50°C	55°C
50%	L/h	1	3	6	11	13
70%	L/h	1	2	4	7	8
80%	L/h	1	1	2	4	5
Water consumption = Liters per hour						

Truck Master 3						
Vacuum	Temp	Choose your water temperature				
		20°C	30°C	40°C	50°C	55°C
50%	L/h	2	7	14	25	31
70%	L/h	1	4	9	15	19
80%	L/h	1	3	6	10	13
Water consumption = Liters per hour						

Truck Master 1700						
Vacuum	Temp	Choose your water temperature				
		20°C	30°C	40°C	50°C	55°C
50%	L/h	4	12	24	44	54
70%	L/h	2	7	15	26	32
80%	L/h	2	5	10	17	21
Water consumption = Liters per hour						

Truck Master 2500						
Vacuum	Temp	Choose your water temperature				
		20°C	30°C	40°C	50°C	55°C
50%	L/h	7	20	41	73	89
70%	L/h	4	12	24	44	54
80%	L/h	3	8	16	29	36
Water consumption = Liters per hour						

Truck Master 3400						
Vacuum	Temp	Choose your water temperature				
		20°C	30°C	40°C	50°C	55°C
50%	L/h	10	30	61	109	134
70%	L/h	6	18	37	65	80
80%	L/h	4	12	24	44	54
Water consumption = Liters per hour						

3.8 Water consumption - U.S. Imperial

It is possible to design the liquid separator so that almost 100% of the water is separated from the air. However, the air will be heated up and thereby it can content more water. Also, the relative humidity will go up and end near 100%. So, the air will flow into the pump with maybe 50% relative humidity at a low temperature and be discharged +at a higher temperature and humidity. Therefore, there will be an evaporation from the system.

Truck Master 2		Choose your water temperature				
Vacuum	Temp	68°F	86°F	104°F	122°F	131°F
		50%	US gal/min	0.004	0.013	0.026
70%	US gal/min	0.004	0.009	0.018	0.031	0.035
80%	US gal/min	0.004	0.004	0.009	0.018	0.022
Water consumption = US gallons per minute						

Truck Master 3		Choose your water temperature				
Vacuum	Temp	68°F	86°F	104°F	122°F	131°F
		50%	US gal/min	0.009	0.031	0.061
70%	US gal/min	0.004	0.018	0.040	0.066	0.084
80%	US gal/min	0.004	0.013	0.026	0.044	0.057
Water consumption = US gallons per minute						

Truck Master 1700		Choose your water temperature				
Vacuum	Temp	68°F	86°F	104°F	122°F	131°F
		50%	US gal/min	0.018	0.053	0.106
70%	US gal/min	0.009	0.031	0.066	0.114	0.141
80%	US gal/min	0.009	0.022	0.044	0.075	0.092
Water consumption = US gallons per minute						

Truck Master 2500		Choose your water temperature				
Vacuum	Temp	68°F	86°F	104°F	122°F	131°F
		50%	US gal/min	0.031	0.088	0.181
70%	US gal/min	0.018	0.053	0.106	0.194	0.238
80%	US gal/min	0.013	0.035	0.070	0.128	0.159
Water consumption = US gallons per minute						

Truck Master 3400		Choose your water temperature				
Vacuum	Temp	68°F	86°F	104°F	122°F	131°F
		50%	US gal/min	0.044	0.132	0.269
70%	US gal/min	0.026	0.079	0.163	0.286	0.352
80%	US gal/min	0.018	0.053	0.106	0.194	0.238
Water consumption = US gallons per minute						

3.9 Dome valve / Float valve system

The liquid ring pump can handle liquid and particles in the inlet but it is of course recommendable to avoid this. A dome valve or float valve will ensure that the suction will be closed when the liquid level reaches the top of the tank. In many situations there will be foam on the liquid surface inside the tank. It can be difficult to avoid that this will be transported into the suction line before the dome valve / float valve will close. Therefore, it will be recommended to make a combination of a filter and dome valve / float valve as illustrated below. The filter will prevent particles lifted by the foam to enter the pump.

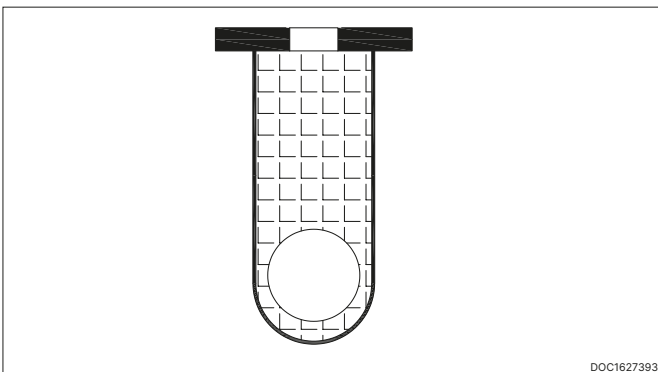

DOC1627393

3.10 Priming of the pump



Zone 0
This chapter relate to Ex Zone 0/1 approved pumps (ATEX category 1 pumps)



When operating the drain valves, the outlet may contain explosive gases, corresponding to the classification of the pump's suction side

After draining the liquid ring pump, prime the pump before start-up.

If the pump is stopped due to missing flow signal from flow, sensors pos 8 or pos 9 the control system must be designed to prime the pump before any restart is possible.

The priming procedure shall open stop valve pos 10 and pos 11 and stay open until the flow sensors pos 8 and pos 9 has positive flow for a continuously period of 10 seconds. Only after this period the system can be started.

3.11 System layout (Zone 1/1)



Zone 1
This chapter relate to Ex Zone 1/1 approved pumps (ATEX category 2 pumps)



The maximum working pressure must not exceed specifications, by installing a safety valve



Install an automatic water supply, for example the shown float valve pos 5 – OR provide the liquid separator with an alarm for low level of water pos 17

Systems in this category can be built as illustrated in fig 1638149 or 1638151.

Use an automatic stop valve pos 10, which opens the water supply to the pump when it starts.

Select only 1 safety device (SD), pos. 5 or pos. 17

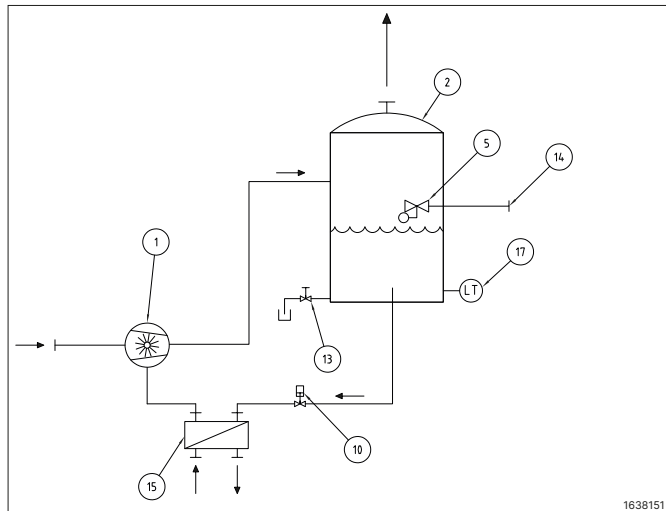

1638151

Pos	Description
1	Vacuum pump
2	Water separator
5	Float valve SD
10	Stop valve
13	Drain valve
14	Water connection
15	Plate heat exchanger
17	Level transmitter SD

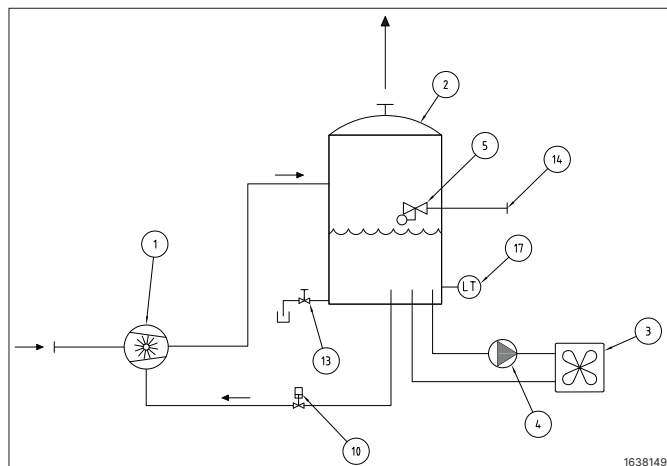

1638149

Pos	Description
1	Vacuum pump
2	Water separator
3	Cooler
4	Circulation pump
5	Float valve SD
10	Stop valve
13	Drain valve
14	Water connection
17	Level transmitter SD

3.12 System layout (Zone 0/1)

Zone 0
 This chapter relate to Ex Zone 0/1 approved pumps (ATEX category 1 pumps)

! The maximum working pressure must not exceed specifications, by installing a safety valve

🚫 Install an automatic water supply, for example the shown float valve pos 5 – OR provide the liquid separator with an alarm for low level of water pos 6

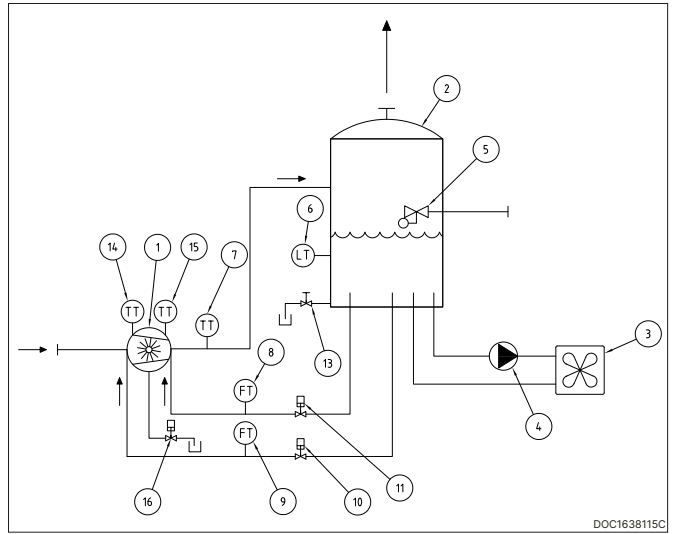

The pump must be fitted with the safety device components specified in drawing below.

The water connection that feeds water to the pump must be fitted with flow meters in positions 8 and 9, on both valve inlets. To prevent the loss of water, stop valves should be installed between the liquid separator and the pump. See Pos. 10 and 11. These valves must be closed when the pump is not in operation.

The opening of the valves must be performed automatically when the pump starts. Max. 1 m / 3.3 ft after the pump, a temperature sensor must be installed in position 7, which also serves as a safety device and which must stop the pump if the output temperature exceeds the limit.

The water level in the liquid separator must be monitored by a level sensor at position 6, which also stops the pump in the event of an insufficient level of water. The 2 temperature sensors are placed in existing M10×1 threaded holes in the bearing housings. This is done by unscrewing existing plugs and mounting sensors instead.

See illustration below.

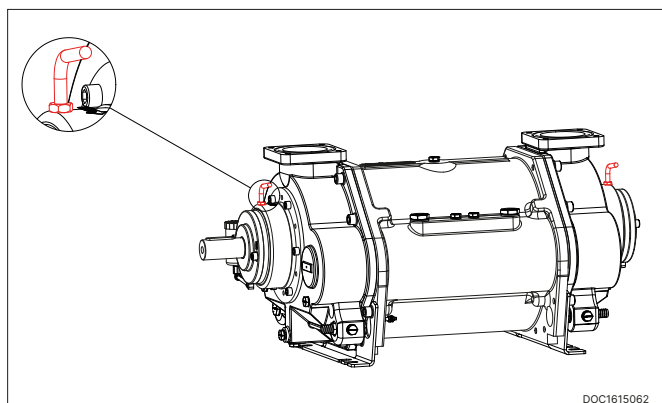

Pos	Description	Safety device	Set
1	Vacuum pump		
2	Water separator		
3	Cooler		
4	Circulation pump		
5	Float valve SD		
6	Level switch	Yes	Min. 50 L / 13.2 US gal
7	Temperature transmitter	Yes	Max. 80°C / 176°F
8	Flow meter	Yes	Min. 2 L/min. / 0.53 US gal/min max. delay 10 sec.*
9	Flow meter	Yes	Min. 2 L/min. / 0.53 US gal/min max. delay 10 sec.*
10	Stop valve		
11	Stop valve		
13	Drain valve		
14	Temperature transmitter DE	Yes	Max. 100°C / 212°F
15	Temperature transmitter NDE	Yes	Max. 90°C / 194°F
16	Drain valve		

* - Maximum pipe length from liquid ring pump 2 m / 6.6 ft.
 See specifications from chapter 3.12 - Water pipe connection, dimension and length.

3.13 Safety Integrity Level (SIL) according IEC 61508



Zone 0
This chapter relate to Ex Zone 0/1 approved pumps (ATEX category 1 pumps)



Zone 1
This chapter relate to Ex Zone 1/1 approved pumps (ATEX category 2 pumps)

Description of Hazard	Position (Sensor)	Safety actionrequired	SIL requirement to safety function
Increased temperature due to absence of water for mechanical shaft seal, NDE	Pos 6 (Level) & pos 8 (Flow)	Stop of pump	SIL2
Increased temperature due to absence of water for mechanical shaft seal, DE	Pos 6 (Level) & pos 9 (Flow)	Stop of pump	SIL2
Unacceptably elevated temperature in pump due to increased temperature of media	Pos 7 (Temperature in media)	Stop of pump	SIL2
Unacceptably elevated temperature of bearing, DE	Pos 14 (Temperature on bearing house)	Stop of pump	SIL2
Unacceptably elevated temperature of bearing, NDE	Pos 15 (Temperature on bearing house)	Stop of pump	SIL2

Fore Zone 1/1 approved pumps there are no SIL requirements for electrical components.

3.14 Water placemant

There are basically three ways of integrating the water for the liquid ring pump in the vehicle structure.

1. Water inside the slurry tank

Placing the water inside the slurry tank, can be done cost effectively by welding in a second dished end. The colling effect from the slurry and vehicle structure will be significant.

Solution Finder colling effect: 1.0

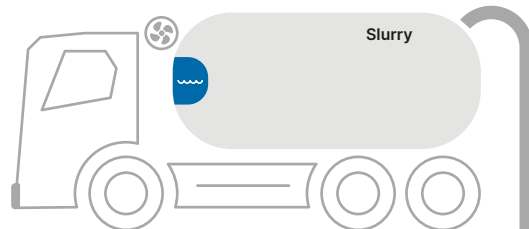

2. Water inside the jetting water tank

Placing the water inside the jetting water tank, can be done cost effectively by welding in a second dished end. The colling effect from the jetting water and vehicle structure will be significant.

Solution Finder colling effect: 1.2

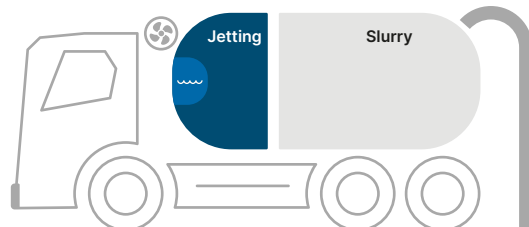

3. Water outside

Placing the water in a tank, separated from the overall vehicle-structure, will provide only a minimum of cooling effect which may require an upsized fan cooler.

Solution Finder colling effect: 0.3

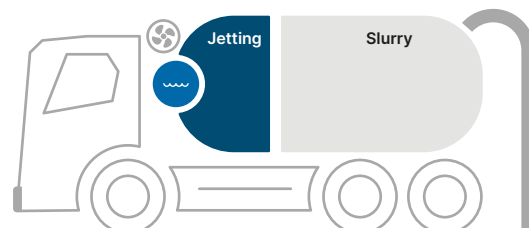

3.15 Water separator



Water separator must be mounted in such way that the minimum level of water is minimum 0.5 m above the pump's shaft



When operating the drain valves, the outlet may contain explosive gases, corresponding to the classification of the pump's suction side



Zone 1
This chapter relate to Ex Zone 1/1 approved pumps (ATEX category 2 pumps)



Zone 0
This chapter relate to Ex Zone 0/1 approved pumps (ATEX category 1 pumps)

The water separator must be located in immediate proximity to the pump, so that the length of the outlet pipe from the pump is minimised. Due to potential pressure loss, the length may not exceed 2 metres / 6.6 ft. The level of water in the water separator is recommended to be kept at 1-1.5 metres / 3.3-5 ft above the pump's shaft. This ensures the correct influx pressure and the correct flow of water.

The water supply between the water separator and pump must be implemented with a permanent pipe connection with a dimension and length specified in specifications.

The water separator can be fitted with a drain valve at the lowest place in the tank. The valve can be operated when the separator needs to be drained to remove contaminants.

3.16 Water requirement

During operation it is normal that small amount of product will enter the pump, or the gas will react with the water which can become aggressive. Drain the liquid separator and refill with fresh water, if the water has become aggressive.

3.17 Pipe system dimensioning



The exhaust from the liquid separator will have the same zone classification as the pump's suction side

The pipes that are connected to the pump's suction and outlet sides must be at least the same dimension as the pump.

The length of the pipe system affects the pump's capacity and should be calculated to account for pressure drop in longer pipe installations.

Depending on the operating pressure, longer pipe lengths may affect the pump's output. For pipe lengths greater than 20 metres, a pressure drop calculation should be made, and the pipe dimensions should be increased so that the pressure loss is held to an acceptable level.

The pipe system should be mounted so that the horizontal pipes have a min. of 1% decline back towards the liquid separator. Table below can be used for reference values.

Model		Pipe system	Non return valve
Truck Master 2	Suction side	DN50	DN50
	Outlet side	DN50	
Truck Master 3	Suction side	DN65	DN80
	Outlet side	DN65	
Truck Master 1700	Suction side	DN100	DN100
	Outlet side	DN100	
Truck Master 2500	Suction side	DN125	DN100
	Outlet side	DN125	
Truck Master 3400	Suction side	DN125	DN125
	Outlet side	DN125	

With respect to the exhaust, measures must be put in place to account for damp air that may form ice in cold surroundings.

3.18 Cavitation

When the temperature reaches the boiling point of the water, steam bobbles will be created in the liquid ring. These bobbles cannot exist when they enter the discharge side of the pump and therefore, they will collapse.

The impact force on the surface of the rotor and flow plate will damage the pump and can lead to a total breakdown. It is a very harmful situation that must be avoided.

It is the combination of the pressure and the temperature that will lead to the cavitation.

Therefore, it is recommended to install a vacuum control valve, see illustration below that shows a clockwise rotating pump. If counter-clockwise rotating pump, mount in opposite manifold.

Vacuum limiters required				
Truck Master 2	Truck Master 3	Truck Master 1700	Truck Master 2500	Truck Master 3400
1 pcs	1 pcs	1 pcs	2 pcs	2 pcs

Vacuum limiters placement

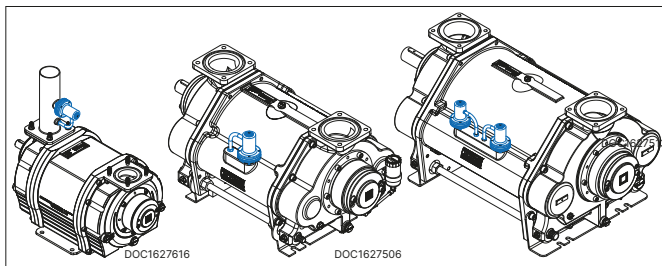

Vacuum		50%	75%	80%	90%
Temperature	°C	90	64	59	44
	°F	194	147	138	111
MAX discharge temperature	°C	70	50	40	30
	°F	158	122	104	86

Zone 0
This chapter relate to Ex Zone 0/1 approved pumps (ATEX category 1 pumps)

Vacuum		50%	75%	80%	90%
Temperature	°C	80	64	59	44
	°F	176	147	138	111
MAX discharge temperature	°C	70	50	40	30
	°F	158	122	104	86

Note that the temperature of the gas inside the pump will heat up the water and the water surface therefore will become a higher temperature than the measured temperature on the discharge side of the pump. Cavitation will therefore start at a lower temperature and the maximum discharge temperature of the water must be kept lower.

3.19 Suction filter

Zone 1
This chapter relate to Ex Zone 1/1 approved pumps (ATEX category 2 pumps)

Zone 0
This chapter relate to Ex Zone 0/1 approved pumps (ATEX category 1 pumps)

In installations where there is a risk of sucking foreign elements into the pump, a filter must be mounted on the pump's suction side with a maximum mesh size of 2 mm / 0.08 in.

4 Installation and start-up

4.1 Securing the pump

Installation requirements must be observed, otherwise there is a risk of damage

The pump must be installed on a stable foundation, which must be level and stable, so that the pump is not twisted or exposed to a profile distortion.

The pump must be installed with 4 pcs. M16 bolts, 2 pcs. in front and 2 pcs. in back. The bolts must be tightened to 180 Nm / 132.8 lbf-ft (A).

Truck Master 2 - 3

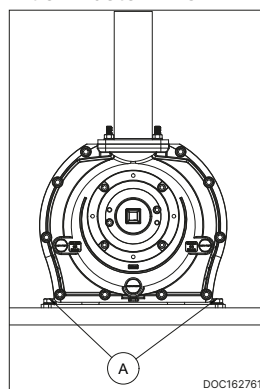

Truck Master 1700 - 2500 - 3400

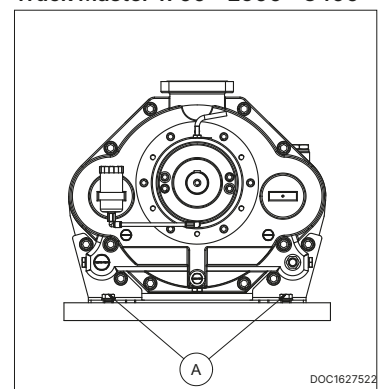

4.2 Connection to the vehicle



- Check for foreign objects in the pump and physical damage on pump
- Gaskets to be handled with highest degree of caution
- Gasket and sealing surfaces must be cleaned before assembly



External effects on the pump may lead to leakage and, as a result, a potential risk of explosion

Immediate before connecting the pipes, remove protective covers. Connection of the pump's suction and pressure pipe connections must be made with a gasket in between (C).

Truck Master 2 - 3

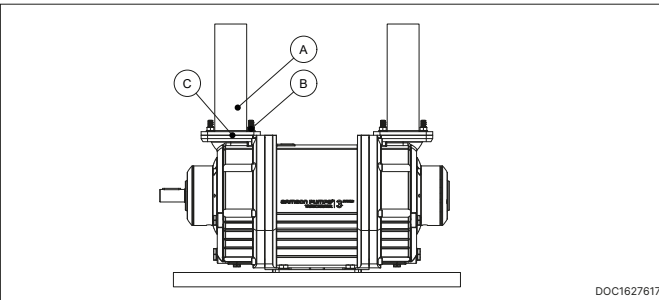

The M10 bolts must be tightened with 55 Nm / 41 lbf-ft and M12 with 100 Nm / 73.8 lbf-ft (B). In order to prevent tensions in the pump, the pipe connections (A) must be tensionless while tightening the bolts.

Truck Master 1700 - 2500 - 3400

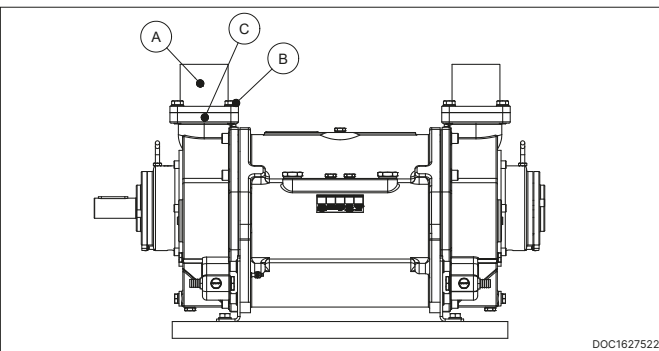

The M16 bolts must be tightened with 180 Nm / 132.8 lbf-ft (B). In order to prevent tensions in the pump, the pipe connections (A) must be tensionless while tightening the bolts.

4.3 Transmission

The pump can be connected direct or through belt transmission. For belt transmission, it must be ensured that the permissible radial force is not exceeded. See specifications.

For belt transmission, note the direction of rotation, see illustration below.

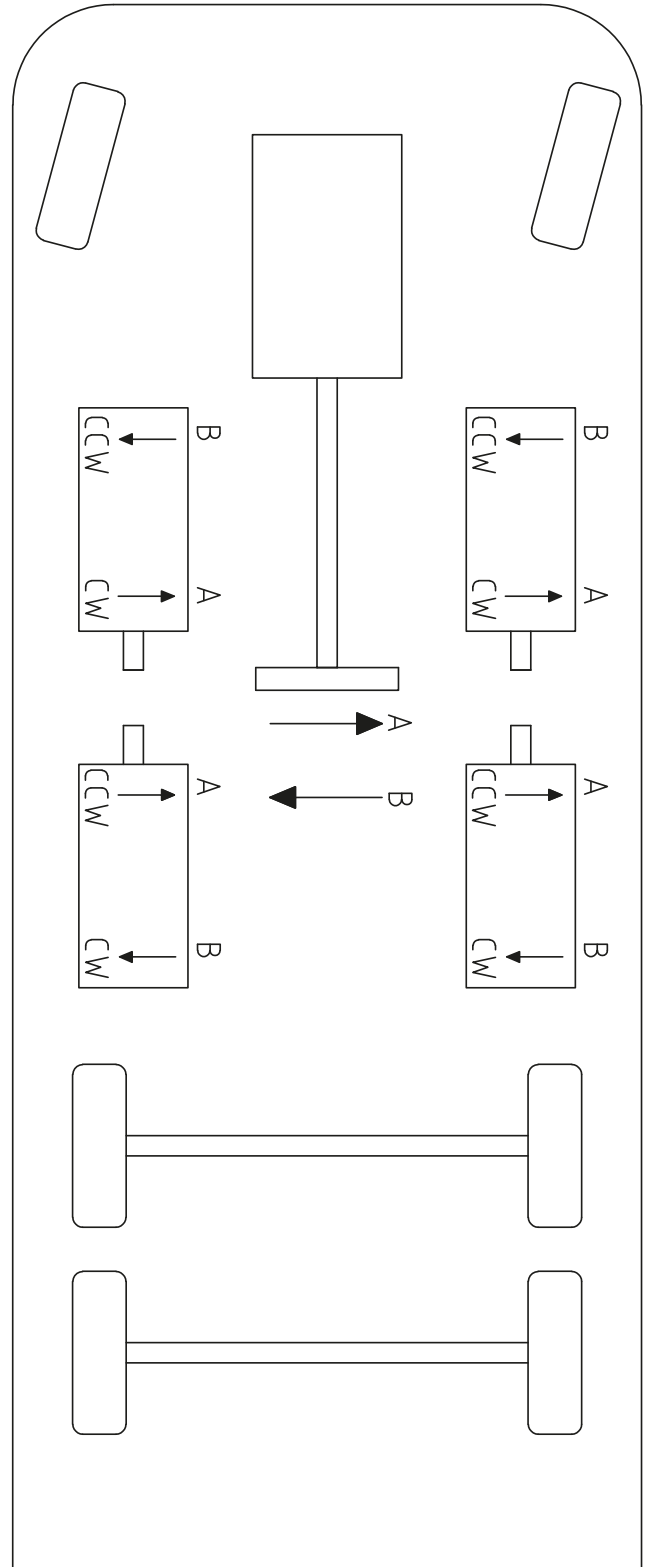

4.4 Earth connection requirements

 The pump must be connected to earth to prevent static electricity. Static electricity is a potential source of ignition

 A failure to meet these specifications may result in damage to the pump and a potential risk of explosion

 **Zone 1**
This chapter relate to Ex Zone 1/1 approved pumps (ATEX category 2 pumps)

 **Zone 0**
This chapter relate to Ex Zone 0/1 approved pumps (ATEX category 1 pumps)

The pump must be protected from the creation of sparks in connection with static electricity, in accordance with the applicable regulations for use in the current categories.

Truck Master 2 - 3

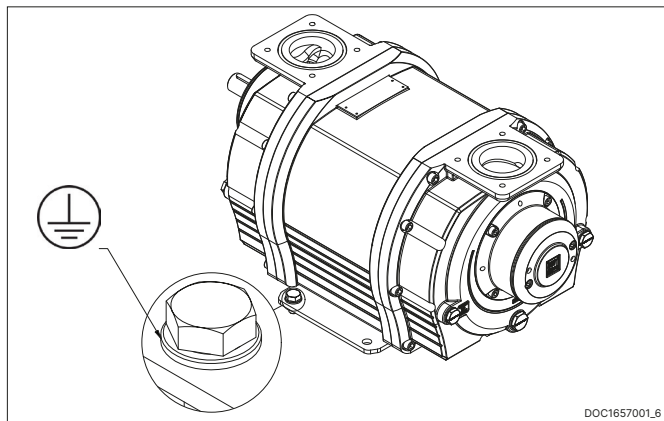

Truck Master 1700 - 2500 - 3400

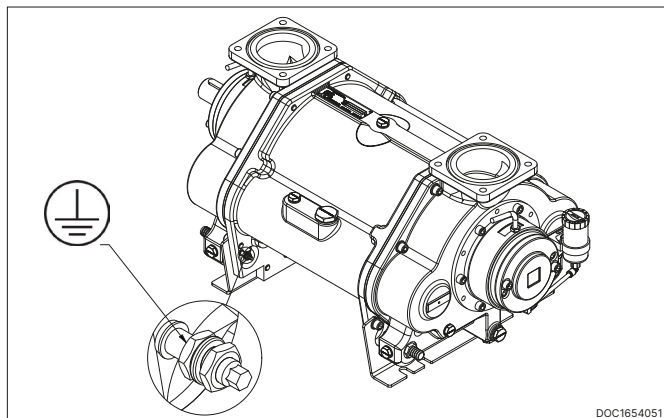

4.5 Direction of rotation

Check the direction of rotation by briefly starting the pump.

The direction of rotation of the rotor must correspond to the direction arrow!

Below left, a right-side pump is shown which has a clockwise direction of rotation (CW)

Below right, a left-side pump is shown which has a counter-clockwise direction of rotation (CCW)

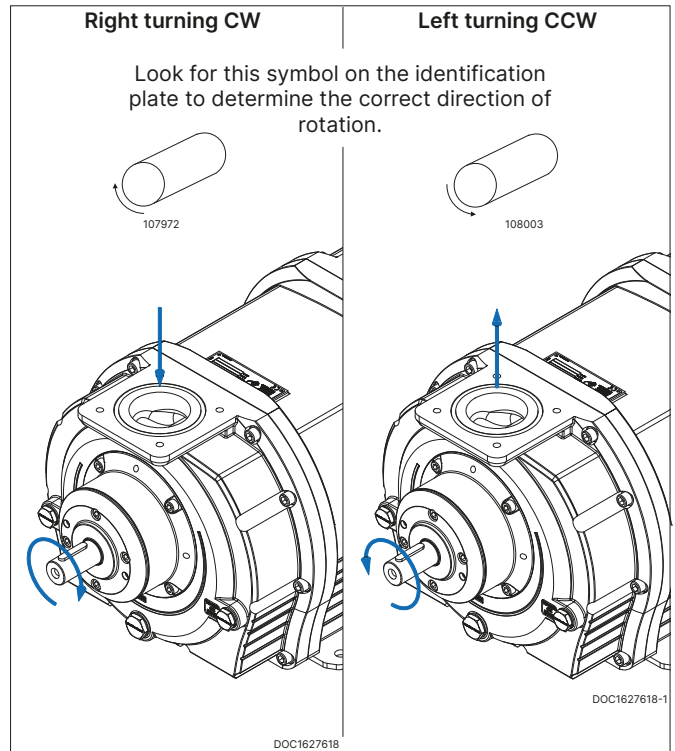

4.6 Prior to start-up





- Do not start the pump without water, as this will damage the mechanical shaft seals
- Do not start the pump if it is completely filled with water
- Do not start the pump before the grease cartridges have been activated, as this can damage the pump (if equipped)
- Stop the pump immediately if the rotational direction does not correspond to the directional arrow
- A failure to follow the above guidelines may result in damage to the pump

5 Service operation and maintenance and inspection intervals



- Check for foreign objects in the pump and physical damage on pump
- Gaskets to be handled with highest degree of caution
- Gasket and sealing surfaces must be cleaned before assembly

Section	Operation	Standard	 Zone 1/1	 Zone 0/1
5.1	Inspection of bearings	Weekly	Daily	Monitored*
5.1	Lubrication of bearings	10.000 duty hours	Per 500 duty hours	Automatic*
5.2	Visually inspect for leakage	Weekly	Weekly	Weekly
3.1.3	Drain water separator	Daily	Daily	Daily
5.3	Check grease cartridges	Weekly	Weekly	Weekly
5.4	Inspection of ATEX safety device	NA	Monthly	Monthly
5.5	Inspection and cleaning (if necessary) of water supply pipe	Monthly	Monthly	Monthly
5.6	Calibration of ATEX safety device	NA	Annually	Annually
5.7	Overhaul of pump	NA	10.000 duty hours	10.000 duty hours
5.8	Inspection and cleaning of internal channels	Monthly	Monthly	Monthly
5.9	Winterization when below	0°C / 32°F	0°C / 32°F	0°C / 32°F
6	Troubleshooting	As required	As required	As required

Monitored = Inspection must be carried out by the overall vehicle control system

Automatic = Automatic grease cartridges is mandatory

5.1 Inspection and lubrication of bearings

Be alert of unfamiliar sounds from bearing.
The measurements are performed after MIN. 30 min. of operation.
If operation time is less than 30 min., perform the measurements immediately after longest period of operation.

Temperature of bearings must not exceed the permitted temperature described in system layout.

Model	Truck Master 2	Truck Master 3	Truck Master 1700	Truck Master 2500	Truck Master 3400
Drive end (DE)	100°C	90°C	100°C	100°C	105°C
	212°F	194°F	212°F	212°F	221°F
Non drive end (NDE)	100°C	90°C	90°C	90°C	95°C
	212°F	194°F	194°F	194°F	203°F

5.2 Visually Inspecting for leakage

The pump and pipe system around the pump must be inspected for leakage once a week. The inspection must be performed when the pump is both operating and idle. Any leaks must be repaired before operation may continue.

5.3 Check grease cartridges (Category 2 pumps with grease cartridges)

 To prevent electrostatic discharge in hazardous areas, only wet cleaning is permitted. Appropriate measures must be taken to prevent electric discharge.

 **Zone 1**
This chapter relate to Ex Zone 1/1 approved pumps (ATEX category 2 pumps)

 **Zone 0**
This chapter relate to Ex Zone 0/1 approved pumps (ATEX category 1 pumps)

If the pump is equipped with an automatic lubrication feature. It must be inspected and replaced as needed.

When the pump is commissioned for the first time, the cartridges must be activated by turning the arrow in the clockwise direction.

The cartridge is set to 12, which corresponds to an emptying time of 12 months.

The cartridge must be replaced when empty.

It is only allowed to use automatic lubricator of type **LAGD 125/WA2**.

Truck Master 1700 - 2500 - 3400

Activating the grease cartridges (Accessories)

Turn the handle in NDE clockwise to position 12.
Turn the handle in DE clockwise to position 12.
The pump has been lubricated from factory and is ready to start.

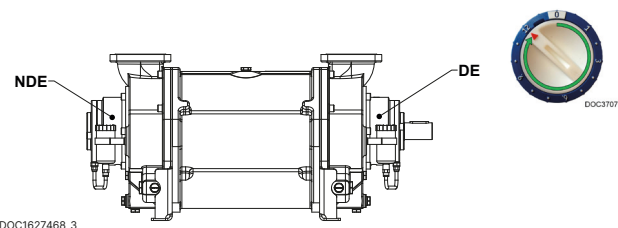

5.4 Inspection of ATEX safety device

 ATEX safety device must be inspected in accordance with table to ensure proper functionality. A failure to perform the required inspections will result in the discontinuation of the pump's approval.

 **Zone 1**
This chapter relate to Ex Zone 1/1 approved pumps (ATEX category 2 pumps)

 **Zone 0**
This chapter relate to Ex Zone 0/1 approved pumps (ATEX category 1 pumps)

Safety devices to be inspected in accordance with applicable regulations.

The components that make up the safety device can be found in the system layout.

Dome Valve / Float valve must be cleaned.

ATEX safety devices can be found in chapter "System layout (Zone" 0/1)

5.5 Inspection and cleaning of water supply pipe

The pipe connection between the liquid separator and pump must be inspected at least once a month, and any contaminants must be removed.

5.6 Calibration of ATEX safety device

Zone 1
 This chapter relate to Ex Zone 1/1 approved pumps (ATEX category 2 pumps)

Zone 0
 This chapter relate to Ex Zone 0/1 approved pumps (ATEX category 1 pumps)

Safety devices (if equipped) must be calibrated once a year in accordance with the applicable requirements. The pump may not be started before the instruments have been re-installed.

5.7 Overhaul of pump

Zone 1
 This chapter relate to Ex Zone 1/1 approved pumps (ATEX category 2 pumps)

Zone 0
 This chapter relate to Ex Zone 0/1 approved pumps (ATEX category 1 pumps)

ATEX approved pumps must be serviced after 10.000 duty hours. This is done by sending the pump to Samson Pumps, or approved and certified partner, upon agreement. The pump must be cleaned before shipment.

Repairs carried out on ATEX pumps may only be performed by Samson Pumps, or approved and certified partner. If this requirement is not observed, and the pump's seal is broken, the pump's declaration of conformity is not valid and Samson Pumps is no longer responsible for any resulting consequences.

Non EX pumps has no limit of duty hours before service is required.

5.8 Inspection and cleaning of internal channels

The pump is designed with internal water channels for lubrication of the mechanical shaft seals. Remove the plugs as listed below and clean the channels using a ø5 mm 150 mm / 5.9 in long screw driver or similar. All connections can be identified in chapter "Connections".

Model	Connections to be cleaned	
	CW	CCW
TM 2	D1. D2	D1. D2
TM 3	D1. D2	D1. D2
TM 1700	C1. C2. H2. H4. H5. H6	C1. C2. H1. H3. H5. H6
TM 2500	C1. C2. H2. H4. H5. H6	C1. C2. H1. H3. H5. H6
TM 3400	C1. C2. H2. H4. H5. H6	C1. C2. H1. H3. H5. H6

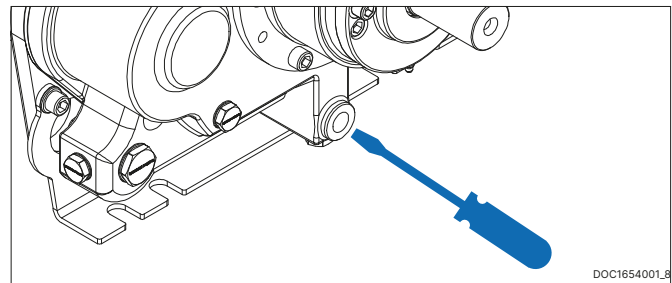

5.9 Winterization

If the pump needs to be used at a temperature below freezing point of the water, it is necessary to protect the liquid from freezing by adding anti freeze liquid.

6 Troubleshooting

Problem	Cause	Effect	Corrective measure
The pump is unable to create a vacuum	<ul style="list-style-type: none"> • Water control valve is closed • The pump is not receiving enough water • The temperature of the water is too high 	<ul style="list-style-type: none"> • Reduced output • The pump can become damaged during cavitation 	<ul style="list-style-type: none"> • Check water control valve • Check the water supply • Stop the pump and wait until the temperature has dropped to a sufficient level, or lower the temperature
The start-up power is too high	<ul style="list-style-type: none"> • Too much water in the pump prior to start-up 	<ul style="list-style-type: none"> • Noise at start-up and possible overload of the power supply 	<ul style="list-style-type: none"> • Check the stop valves in the water supply for leakage
Noise during operation	Cavitation	<ul style="list-style-type: none"> • Severe damage to the pump and potential risk of breakdown 	<ul style="list-style-type: none"> • Increase the suction pressure or lower the temperature of the water
Leakage from the bearing housing's drain holes	<ul style="list-style-type: none"> • Damaged shaft seal 	<ul style="list-style-type: none"> • Bearings may become damaged • Potential risk of explosive gas leak 	<ul style="list-style-type: none"> • Stop the pump and contact the manufacturer

7 Spare parts and tools

7.1 Spare parts

To order spare parts, please visit the Samson Pumps Product center.



Product Center

To identify the correct Generation. Please see chapter Marking and identification

7.2 Marking and identification

