

Ocean Master Solutions

INSTALLATION
OPERATION
MAINTENANCE

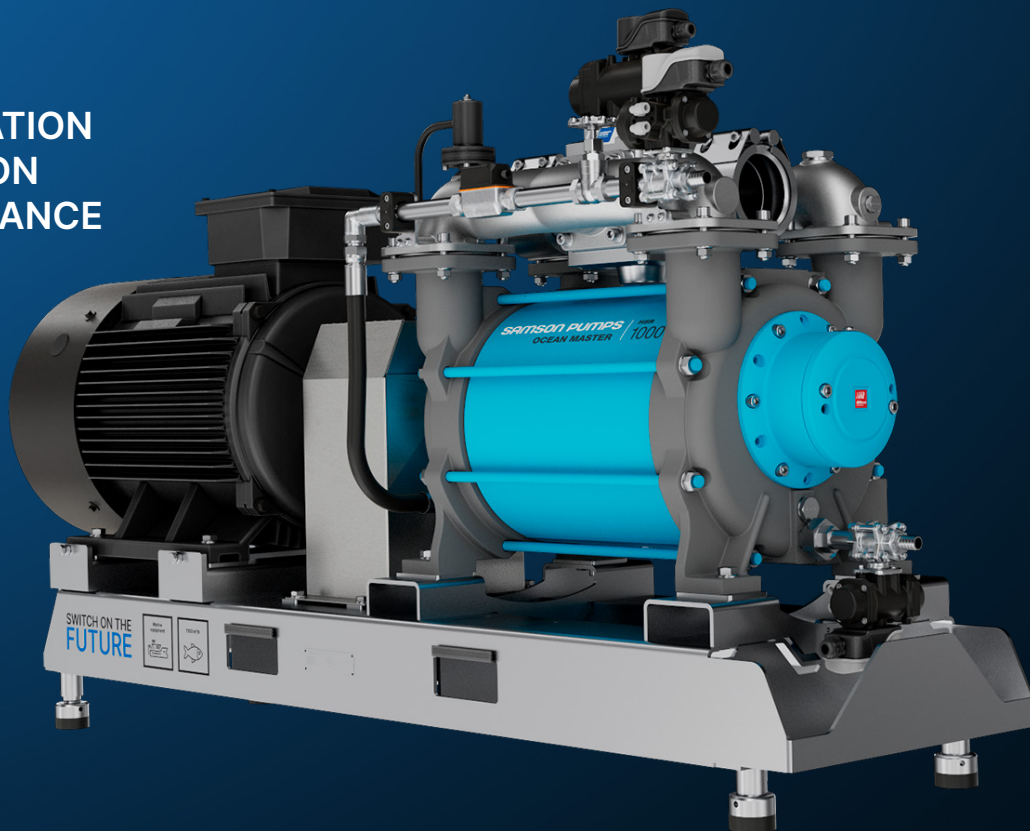

MODELS:
Ocean Master Solution 500
Ocean Master Solution 700
Ocean Master Solution 1000
Ocean Master Solution 1500

Table of content

Page	Chapter	
3	1	Introduction
3	1.1	Declaration of Conformity
4	1.2	Digital services
4	1.3	Explanation of warning symbols
4	1.4	Field of application
4	1.5	Disposal
5	2	Technical data
5	2.1	Specifications
6	2.3	Dimensions
8	2.4	Handling and transport
8	2.5	Storage and draining procedure
9	3	4way valve
9	3.1	Marking and identification
9	3.2	Valve specifications
9	3.3	Actuator specifications
9	3.4	Limit switch specifications
10	3.5	Components
10	3.6	Pneumatic actuator set
10	3.7	Positions - With pneumatic actuator
11	3.8	Installing the 4-way valve
11	3.9	Securing the 4-way valve
11	3.10	Flange connections
11	3.11	Service & maintenance
12	4	Flowsensor
12	4.1	Electrical data
12	4.2	Electrical connection
12	4.3	Connection
13	5	Vacuum control valve
13	5.1	Functional description
13	5.2	Installation
13	5.3	Adjustment
14	6	Design of a system
14	6.1	Overview
14	6.2	Service liquid adjustment - Pressure method
14	6.3	Piping
15	6.4	Service liquid pump
15	6.5	Pump performance
15	6.6	Pressure drop
16	6.7	Service liquid requirement
16	7	Installation & start-up
16	7.1	Securing the pump
16	7.2	Connections to the pump
17	7.3	Connecting the service liquid
17	7.4	Drive
17	7.5	Direct drive
17	7.6	Belt drive
18	7.7	Prior to start-up
18	7.8	Direction of rotation
19	8	Service operation and maintenance and inspection intervals
19	8.1	Check grease cartridges - Only belt drive
19	8.2	Winterization
19	8.3	Inspection and cleaning of service liquid supply pipe
20	9	Troubleshooting
21	10	Marking & identification

1 Introduction

1.1 Declaration of Conformity



Declaration of Conformity

Annex IIA

Samson Pumps A/S
Petersmindevej 21
DK-8800 Viborg

Hereby declares that the following products:

Liquid ring pump and Solutions

Ocean Master 250, Ocean Master 450

Ocean Master 500, Ocean Master 700, Ocean Master 1000, Ocean Master 1500

Ocean Master SVF27

Ocean Master Solution 500, Ocean Master Solution 700

Ocean Master Solution 1000, Ocean Master Solution 1500

Conforms to the directive:

Machinery Directive 2006/42/EC

I hereby declare that the liquid ring pumps are in conformity with the following harmonized standards:

DS/EN ISO 12100:2011	Safety of machinery - General principles for design - Risk assessment and risk reduction
DS/EN 1012-2 + A1:2009	Compressors and Pumps - Safety requirements - Part 2: Vacuum pumps

The standards above only apply to the extent that it is relevant for the purpose of the product.

The product must not be used before the complete system, which it must be incorporated in, has been conformity assessed and found to comply with all relevant health and safety requirements of 2006/42/EC and other relevant directives. The product must be included in the overall risk assessment.

Viborg, 30.04.2024

Jan S. Christiansen – Manager, Technical dept.

1.2 Digital services

Samson Pumps offers a number of digital services to help our customers gain the best possible output from our products.

Calculate



Solution Finder

Buy



Product center

1.3 Explanation of warning symbols

Important technical and safety instructions are shown by symbols. If the instructions are not performed correctly, it can lead to personnel injuries or incorrect function of the pump.



To be used with all safety instructions that must be followed. A failure to follow the instructions may result in injuries and/or incorrect machine operation

1.4 Field of application



- Inlet of foreign objects can damage the pump
- The pump is designed exclusively to pump gases, including atmospheric air
- **WARNING!**
Avoid cavitation of the pump! For further information, see instruction manual for the Samson Pumps vacuum control valve (optional)

It must be ensured that the inlet gas cannot react with the water and create aggressive bonds that break down the pump's components. For other operating data, see specifications. The pump can only be used with media that is not aggressive to the pump's materials.

The pump may only be used with media that are not aggressive to the pump's materials. See section 7.3 for components and appertaining materials.

1.5 Disposal

Samson's liquid ring pump is manufactured so that most of the device can be reused/recycled. Samson Pumps offer all users the option of returning used products to be restored or scrapped.

Alternatively, the pump must be taken apart and sorted into its separate components, by the customer (see section 7 for the pump's material). These components must be disposed of in accordance with national regulations.

2 Technical data

2.1 Specifications



A failure to meet these specifications may result in damage to the pump

General specifications	Type	Ocean Master Solution 500	Ocean Master Solution 700	Ocean Master Solution 1000	Ocean Master Solution 1500
Ambient temperature, operation	Maximum	55°C	55°C	55°C	55°C
	Minimum	-20°C	-20°C	-20°C	-20°C
Ambient temperature, storage	Maximum	55°C	55°C	55°C	55°C
	Minimum	-20°C	-20°C	-20°C	-20°C
Humidity	Maximum	100%	100%	100%	100%
Intake temperature, suction side	Maximum	60°C	60°C	60°C	60°C
Intake temperature, water	Maximum	60°C	60°C	60°C	60°C
Service liquid pipe connection, dimension	G	3/4"	3/4"	3/4"	3/4"
Noise level (measured 7 m from pump)	dB(A)	63 dB(A)	63 dB(A)	63 dB(A)	63 dB(A)
Noise level (measured 1 m from pump)	dB(A)	80 dB(A)	80 dB(A)W	80 dB(A)	80 dB(A)
Water volume	L	32 L	42 L	52 L	72L
Maximum radial load on drive shaft	Belt drive	3800 N	3900 N	4800 N	7200N
	Direct drive	-	-	-	-
Revolutions	Maximum	1800 RPM	1800 RPM	1800 RPM	1500 RPM
	Minimum	800 RPM	800 RPM	800 RPM	800 RPM
Pressure	Maximum	3 bar(g)	3 bar(g)	3 bar(g)	3 bar(g)
	Minimum	150 mbar abs.	150 mbar abs.	150 mbar abs.	150 mbar abs.
Lubricating grease (Only belt drive)	Type of grease	SKF LGHQ2	SKF LGHQ2	SKF LGHQ2	SKF LGHQ2
	Automatic lubrication	SKF LAGD 125/HQ2	SKF LAGD 125/HQ2	SKF LAGD 125/HQ2	SKF LAGD 125/HQ2
Weight	Pump kg	191 kg	209 kg	253 kg	428 kg
	Manifolds kg	18 kg	22 kg	26 kg	42 kg
	4 way valve kg	25 kg	25 kg	25 kg	43 kg
	Water system kg	4 kg	4 kg	4 kg	4 kg
	Straub coupling kg	4 kg	4 kg	4 kg	7 kg
	Vacuum valve kg	0,5 kg	0,5 kg	0,5 kg	0,5 kg
	Total kg	242 kg	265 kg	312 kg	525 kg
Casted parts, except Manifold	All	Cast iron	Cast iron	Cast iron	Cast iron
Casted Manifold	All	Duplex S. Steel	Duplex S. Steel	Duplex S. Steel	Duplex S. Steel
Shell	All	Stainless steel	Stainless steel	Stainless steel	Stainless steel
Rotor shaft	All	Stainless steel	Stainless steel	Stainless steel	Stainless steel
Rotor	All	Stainless steel	Stainless steel	Stainless steel	Stainless steel
Skid	All	Stainless steel	Stainless steel	Stainless steel	Stainless steel
Surface treatment	All	E-coat	E-coat	E-coat	E-coat

2.3 Dimensions

Ocean Master Solution with 4 way valve

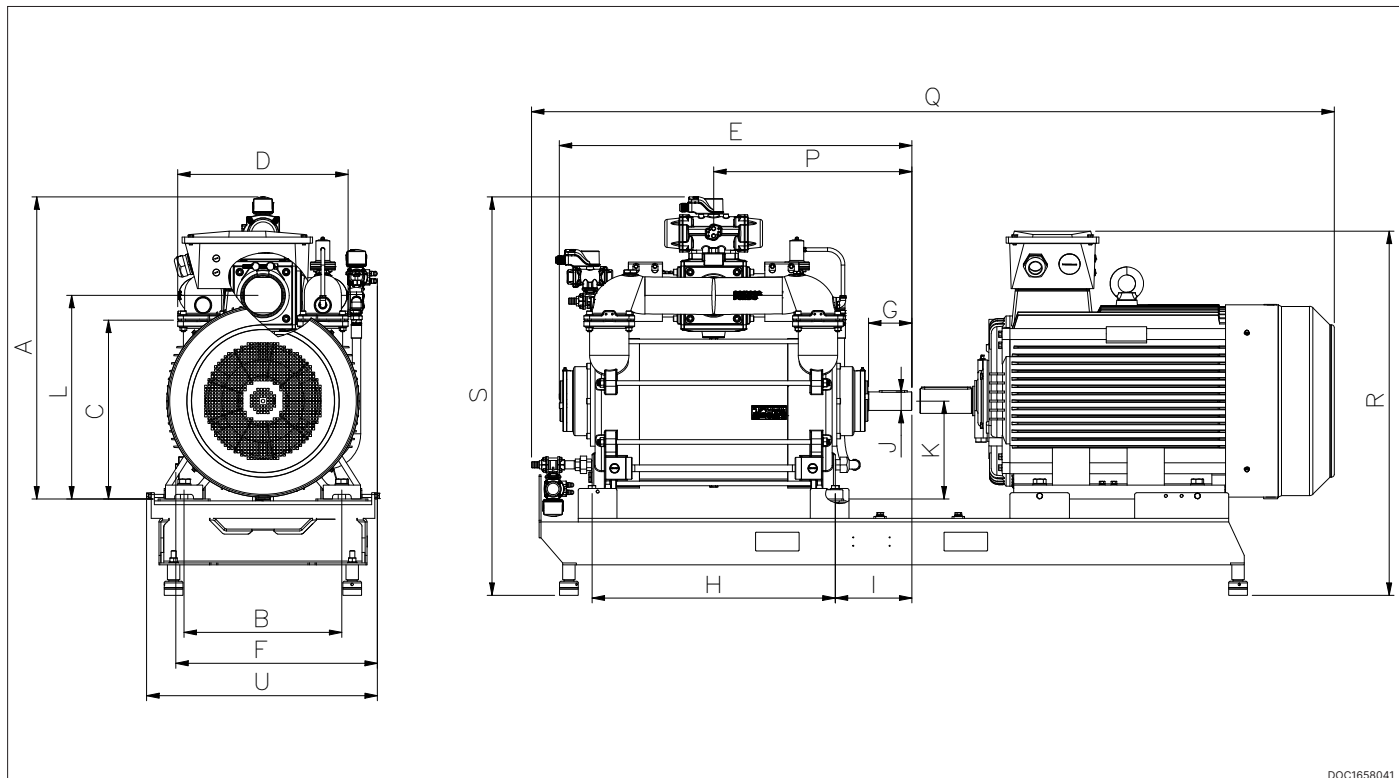

DOC1658041

Model	A	B	C	D	E	F	G	H	I	J	K	L	Q	R	S	U
Ocean Master Solution 500	812	320	472	478	689	550	86	388	195	35	249	538	1604	910	1024	579
Ocean Master Solution 700	812	320	472	478	761	550	86	458	195	35	249	538	1696	917	1024	593
Ocean Master Solution 1000	812	320	472	478	901	550	86	598	195	45	249	538	2044	977	1024	632
Ocean Master Solution 1500	973	415	576	578	1136	650	139	773	252	60	315	656	2568	1187	1298	749

Ocean Master Solution prepared for pipe work

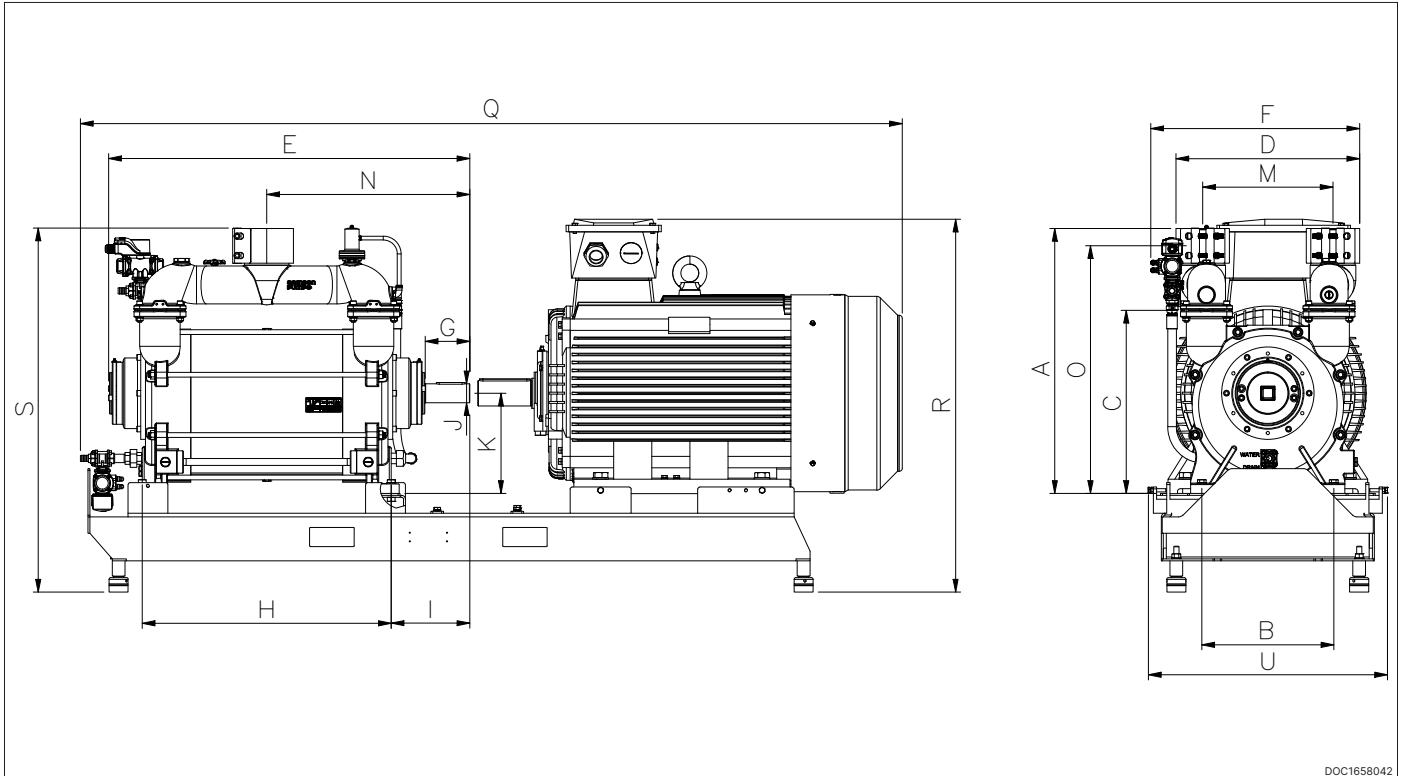

DOC1658042

Model	A	B	C	D	E	F	G	H	I	J	K	O	Q	R	S	U
Ocean Master Solution 500	692	320	472	478	689	550	86	388	195	35	249	642	1604	910	1016	579
Ocean Master Solution 700	692	320	472	478	761	550	86	458	195	35	249	642	1696	917	1016	593
Ocean Master Solution 1000	692	320	472	478	901	550	86	598	195	45	249	642	2044	977	1016	632
Ocean Master Solution 1500	836	415	576	578	1136	650	139	773	252	60	315	782	2568	1187	1160	749

2.4 Handling and transport











A failure to meet these specifications may result in damage to the pump

The pump must be transported in such way that it is not exposed to vibrations and impacts that can overload the bearings.

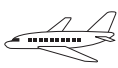
The pump must be inspected for damages upon delivery. If the pump is damaged, it must not be used, and the damage must be reported to the manufacturer.

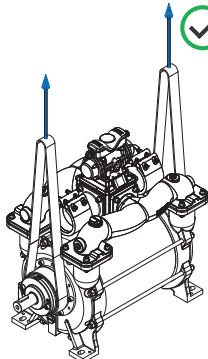
Ensure that the pump's identification plate is intact and that the marking of the pump corresponds to its use. The pump must only be handled using approved lifting eyes, in accordance with nationally applicable regulations and only in a vertical motion.

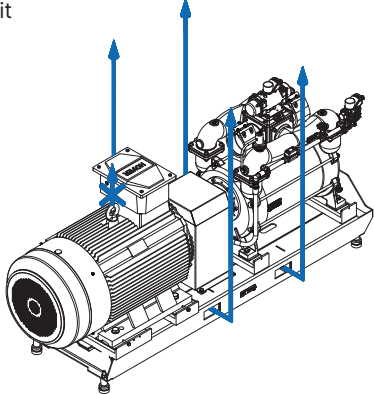
Handling & transport	
Road	  <small>DOC11093A</small>
Sea	  <small>DOC11093A</small>
Air	  <small>DOC11093A</small>
Crane / pump	  <small>DOC1627542B</small>
Crane unit	 <small>DOC1627623A</small>

2.5 Storage and draining procedure



A failure to comply with the requirements for storing the pump may result in internal damage to the device



If the temperature is below freezing point of the water, it could damage the pump. Under these conditions, the pump must be drained completely



All plugs and protective covers must be fitted during storage

The pump's water is drained on delivery, and the pump can be immediately stored in accordance with the technical specifications. After operation, the pump can be stored for 30 days without further action. If the pump remains out of operation for a longer period of time after use, its water must be drained, and the water supply to the pump must be shut off.

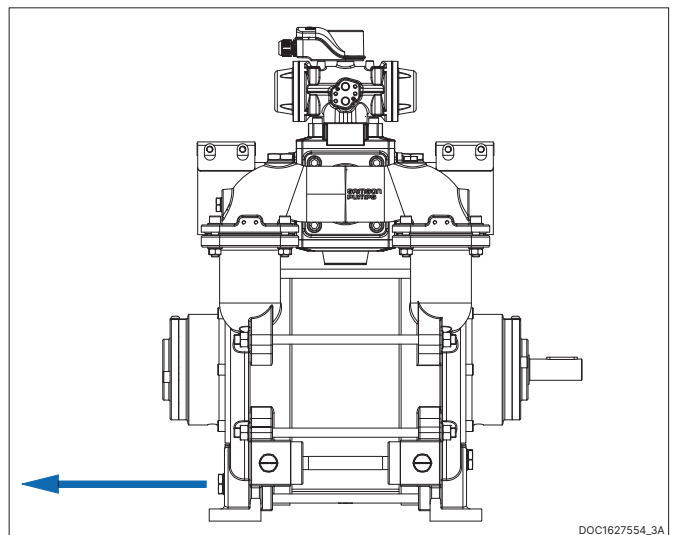

3 4way valve



The following chapter includes the 4 way valve exclusively. Therefore its only relevant for units configured with 4 way valve or customers who purchased the valve as a stand alone product

3.1 Marking and identification

The 4way valve is equipped with an Serial No. as shown below.

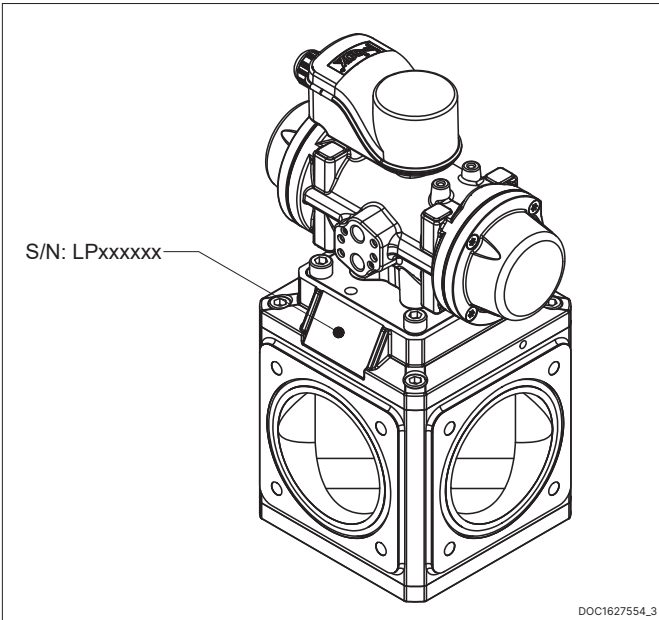

DOC1627554_3

3.2 Valve specifications

A failure to comply with the requirements for storing the valve may result in internal damage to the device

Description		DN100	DN125
Ambient temperature MAX	Operation	40°C	40°C
	Storage	60°C	60°C
Ambient temperature MIN	Operation	-20°C	-20°C
	Storage	-20°C	-20°C
Pressure MAX		3 bar(g)	3 bar(g)
Pressure MIN		65 mbar abs.	65 mbar abs.

3.3 Actuator specifications

Double Acting polyamide pneumatic actuator, fit for marine and underwater installations.

Description		DN100	DN125
2 positions		Suction & Pressure	
Normal working temperature	MIN	-32°C	
	MAX	80°C	
Norms of construction		ISO-5211, DIN-3337 VDE-3845, NAMUR	
May be actioned with		Air	
Max pressure		8 bar	

3.4 Limit switch specifications

Compact limit switch box for direct mounting, plastic.

Description	DN100	DN125
Housing type	IP Enclosure IP66 + IP67 according to DIN EN 60529	
Housing/bracket/shaft material	PA6 + PC / Stainless steel AISI 303	
Visual indicator	OPEN-CLOSED	
Actuator hole spacings	(Optional with IMBHV: 130×30 mm, 50×25 mm)	
Connections	1x M20×1,5 With cable gland	

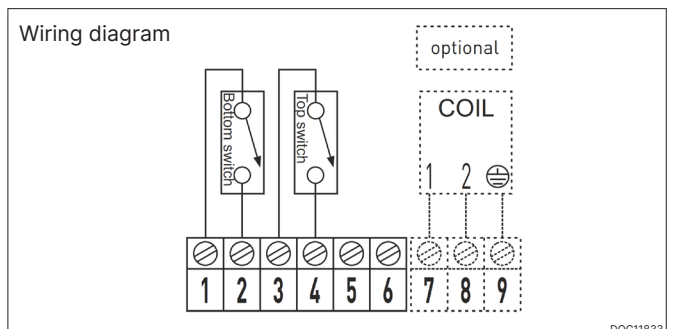

DOC11833

3.5 Components

The 4-way valve is composed by two main components:

- 4-way valve (Pos 1)
- Actuator set (Pos 2)

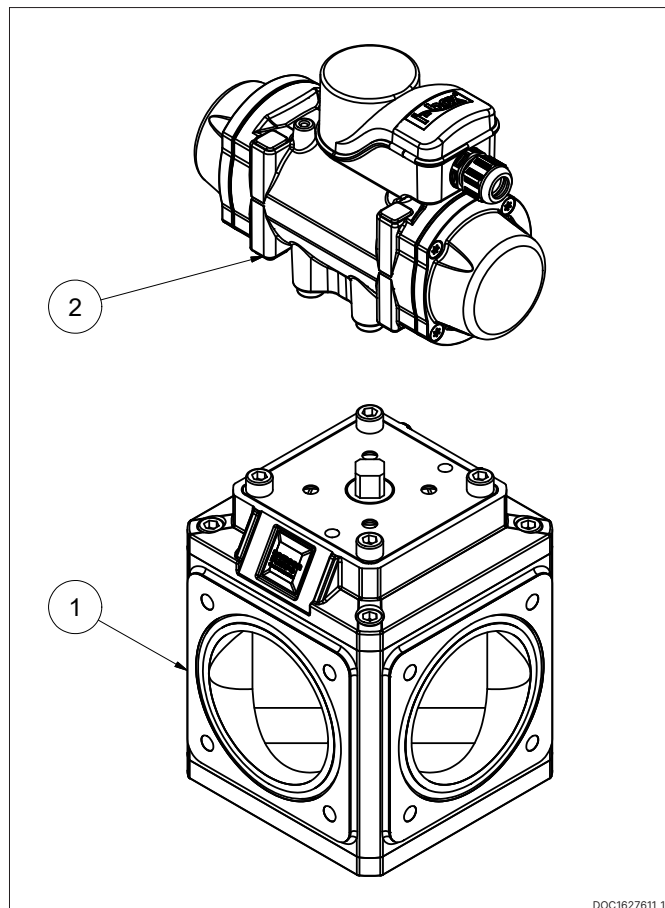

3.6 Pneumatic actuator set

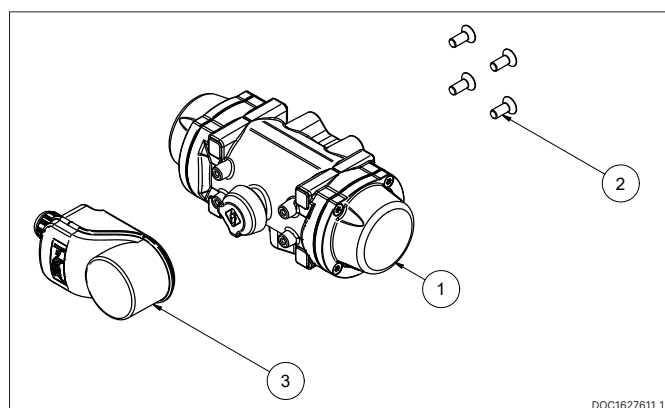

Pos	Description	Qty.	Material
1	Pneumatic actuator	1	Plastic
2	Screw	4	Stainless steel
3	Feedback switch for pneumatic actuator	1	Plastic

3.7 Positions - With pneumatic actuator

By connecting compressed air to connection 4 on the 4-way valve. See below.

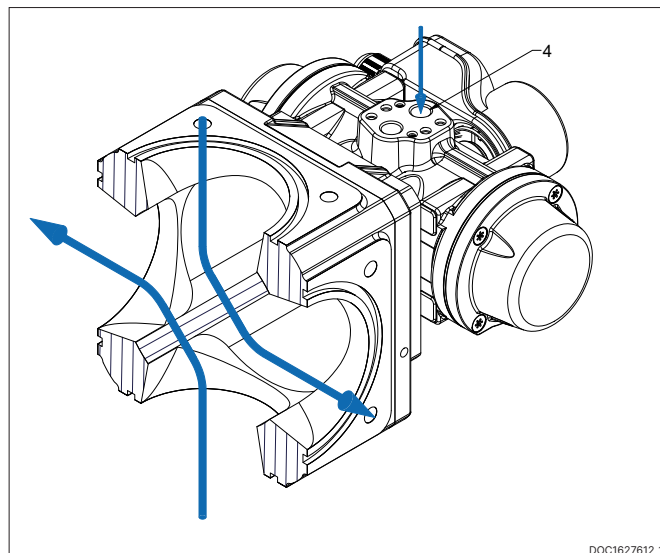

DOC1627612_1

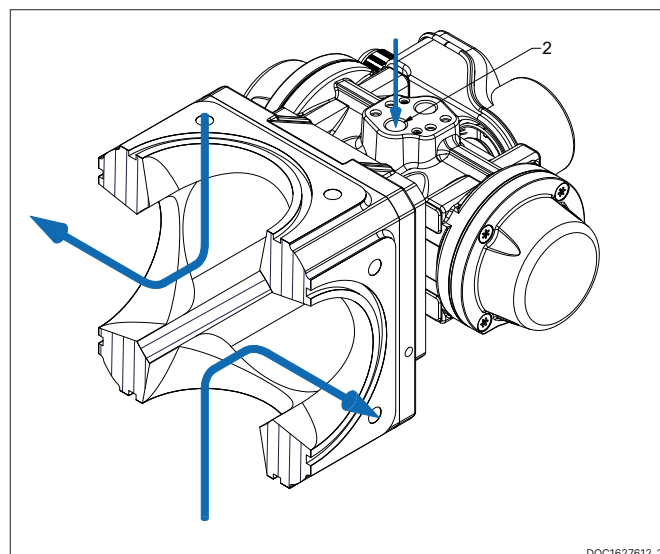

DOC1627612_2

3.8 Installing the 4-way valve

All horizontal and vertical positions are allowed.

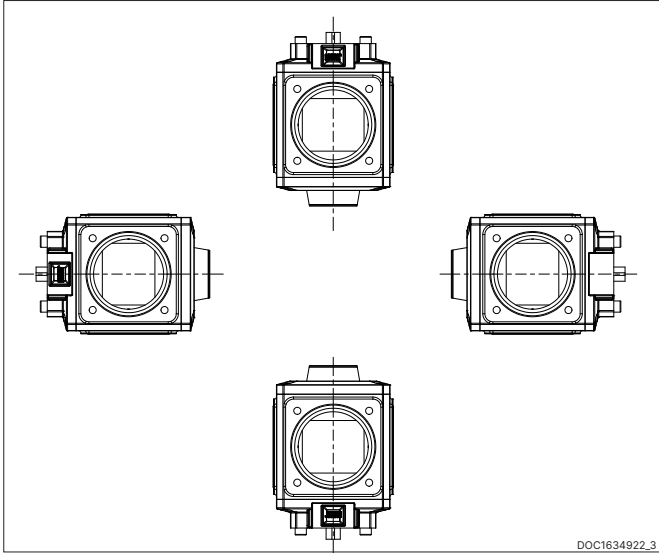

3.9 Securing the 4-way valve

! A failure to comply with the requirements for storing the valve may result in internal damage to the device

The 4-way valve must be installed on a stable foundation, which must be level and stable, so that the 4-way valve is not twisted or exposed to a ± 0.1 mm profile distortion. Bolts must be tightened in accordance with supplier's instructions.

Ensure that the flow direction is correct before assembly. The 4-way valve's end stop can only be used as a stop when operating with manual handle bar. When activated with a cylinder, the cylinder's own end stop is used.

3.10 Flange connections

Deflection on the flanges from the welding process can affect the tolerances inside the valve and block the cones free rotation.

Therefore its important to use machined flanges or alternatively use maximum 8 mm flanges. See below illustration.

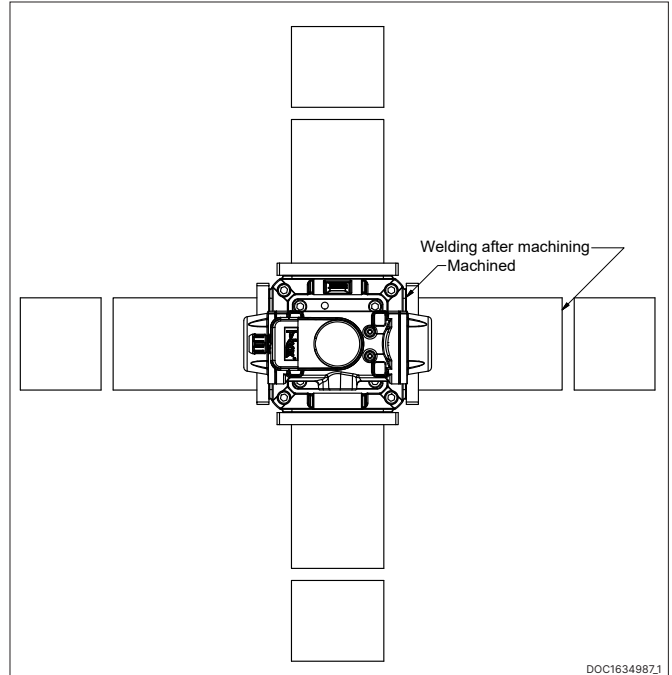

3.11 Service & maintenance

! A failure to comply with the requirements for storing the valve may result in internal damage to the device

Only qualified personnel may carry out repairs. Use only original materials and components as described, during repair and maintenance. During repair or disassembly, check that the flow direction remains unchanged.

Operation	Interval.
Visually inspect for leakage	Weekly
Inspection and cleaning (if necessary)	Monthly

Inspecting for leakage

The 4-way valve and pipe system around, must be inspected for leakage once a week. The inspection must be performed when the 4-way valve is both operating and idle. Any leaks must be repaired before operation may continue.

Inspection and cleaning

The pipe connections of 4-way valves must be inspected at least once a month, and any contaminants must be removed. The 4-way valve must always run easily and effortlessly, otherwise it must be cleaned.

4 Flowsensor



Installation requirements must be observed, otherwise there is a risk of damage

Type: Vortex flow meter with display
 Brand: IFM
 Item: SVR34XXX50KG/US-100

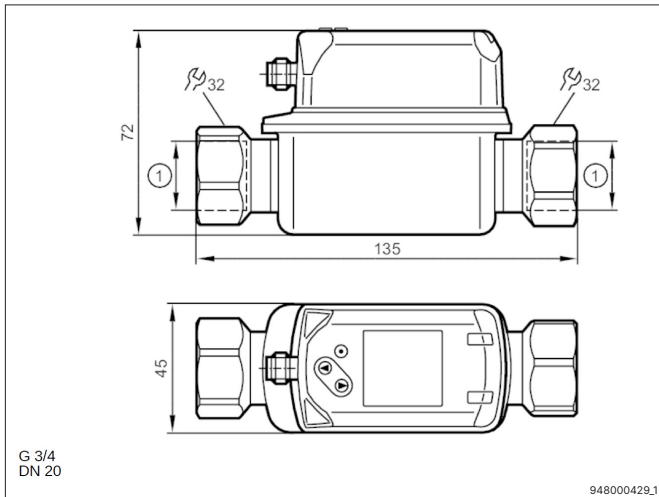

4.2 Electrical connection

Electrical connection

Connector: 1 x M12; Contacts: gold-plated

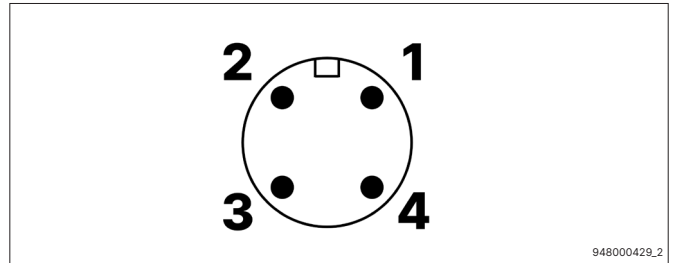

4.3 Connection

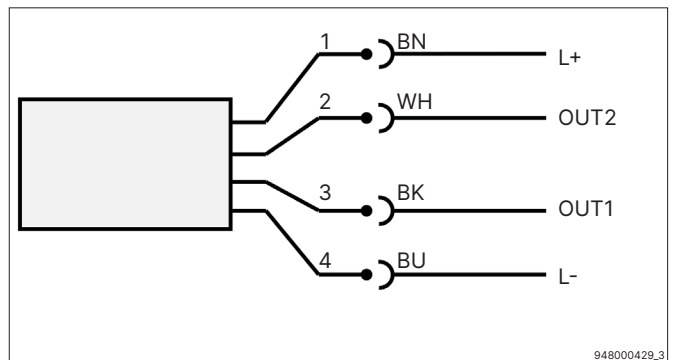

4.1 Electrical data

Electrical data

Operating voltage	[V]	18...30 DC
Current consumption	[mA]	< 30
Min. insulation resistance	[MΩ]	100; (500 V DC)
Protection class		III
Reverse polarity protection		yes
Power-on delay time	[s]	< 3

Output

OUT1: Analogue output Temperature monitoring

OUT2: Analogue output volumetric flow quantity monitoring

Colours: DIN EN 60947-5-2

BK = Black

BN = Brown

BU = Blue

WH = White

5 Vacuum control valve

5.1 Functional description



A failure to comply with the requirements for storing the pump may result in internal damage to the device

The SAMSON vacuum control valve is designed to control the pressure (vacuum) level and to avoid cavitation in the pump.

The vacuum control valve is installed when the suction line may force the pump to operate below the cavitation limit. Air must then be supplied to the suction side of the pump through the vacuum control valve, which is regulated according to the required pressure.

Cavitation arises when the pressure in the pump falls to under the steam pressure of the water, which makes the water boiling and steam bubbles arise in the water. Continuous operation will cause great mechanical damage.

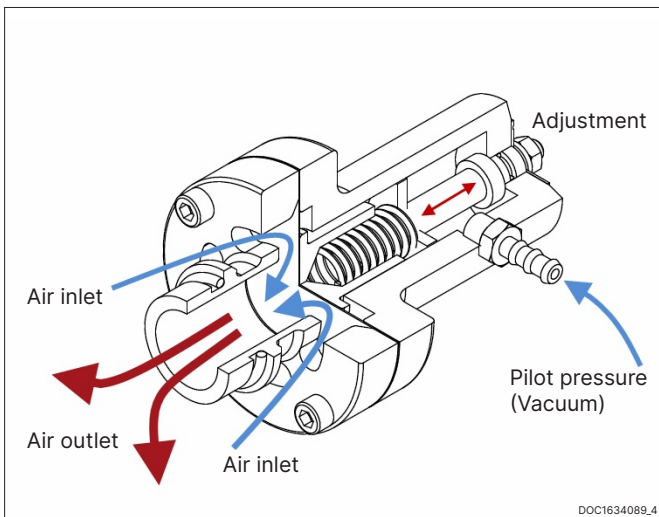

DOC1634089_4

5.2 Installation



The vacuum control valve may not be used or installed if it is damaged.

- Install the vacuum control valve on the suction line by using the 1" BSP thread.
- Connect the hose to the suction line by using the 1/8" BSP nipple hose and the two straps, which are included in the kit.
- If you have an existing installation, you are able to use M6 nipple hose on your suction line. It is recommended to adjust the valve to the lowest possible set pressure in order to avoid cavitation in the pump and undesired noise from the air inlet.

Note:

It is recommended to adjust the valve to the lowest possible set pressure in order to avoid cavitation in the pump and undesired noise from the air inlet.

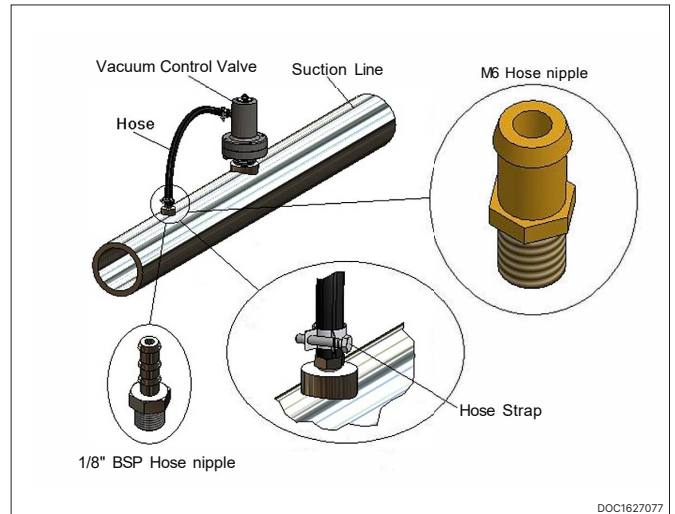

DOC1627077

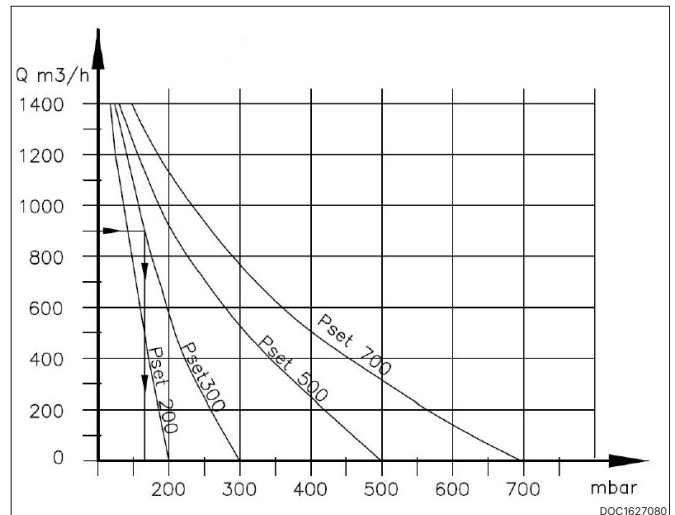

DOC1627080

5.3 Adjustment

- Step 1) When the pump is running, close the valve by turning the M6 set screw counter clockwise (-direction)
- Step 2) Open the valve by turning the set screw clockwise (+direction), until the required set pressure is reached.

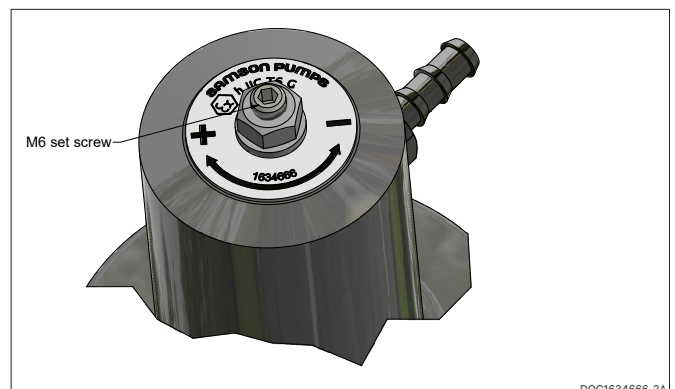

DOC1634666_2A

6 Design of a system

6.1 Overview

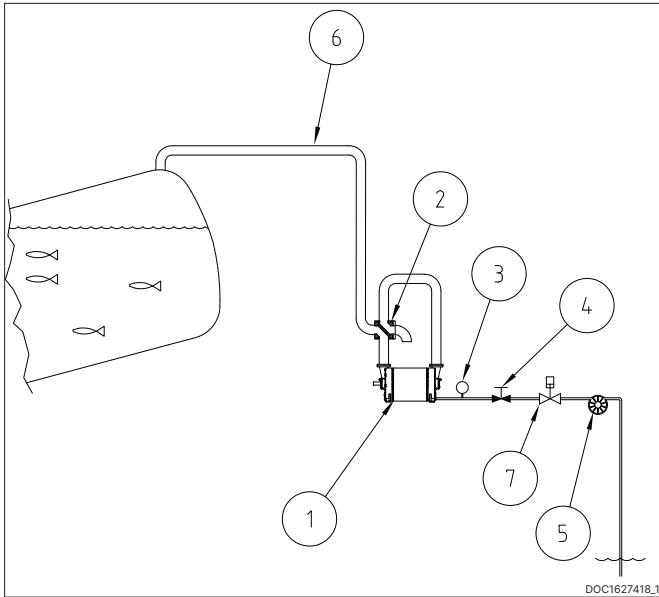

Pos	Description
1	Liquid ring pump
2	4-way valve
3	Pressure gauge
4	Regulating valve
5	Water pump
6	Pipe connection - Critical pipe
7	Stop valve

6.2 Service liquid adjustment - Pressure method

In order to get the correct water pressure to the pump it is recommended to build the supply line as illustrated below. For correct service liquid supply, the pressure needs to be adjusted to between 0,6 and 0,8 bar(g) when the pump is running unloaded.

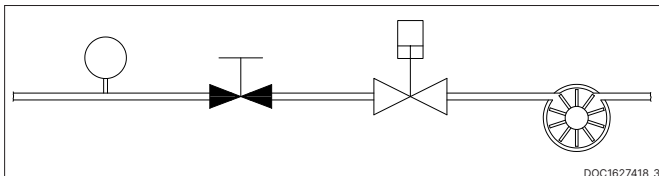

6.3 Piping

In a fish handling system, where the pump is working without liquid separator, the piping can be critical.

The pipe pos 6 will be a combination of a discharge and a suction pipe and the design of this pipe is very important.

Figure below shows a standard setup. When the pump is discharging, the tank pipe pos 6 will carry a mixture of air and water, which is the sealing water supplied to the pump. When the 4 way valve pos 2 change position this pipe becomes the suction pipe and water that is in the pipe will enter the pump. In a normal situation a small vibration will follow when the pump is injected with water on the suction side.

It is important to keep a high velocity > 30 m/s in this pipe and design it as short as possible without "water traps". The velocity can be calculated based on the nominal flow and the pipe diameter. Another and safer solution is to place the 4 way valve closer to the fish tank as illustrated below.

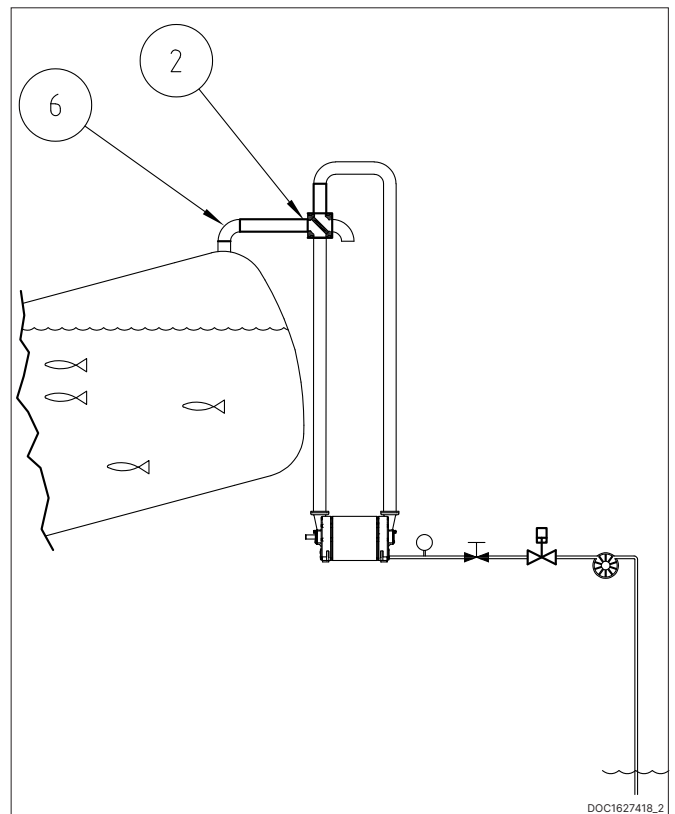

6.7 Service liquid requirement

If sea water is used as sealing water, it is recommended to flush the pump with fresh water (inlet A or B) after use and drain the pump (outlet C) afterwards. See illustration below.

Before the pump is started again, remember to fill the pump to about shaft height before start up. Otherwise the pump will be started with dry run of the mechanical shaft seals, which will shorten the lifetime.

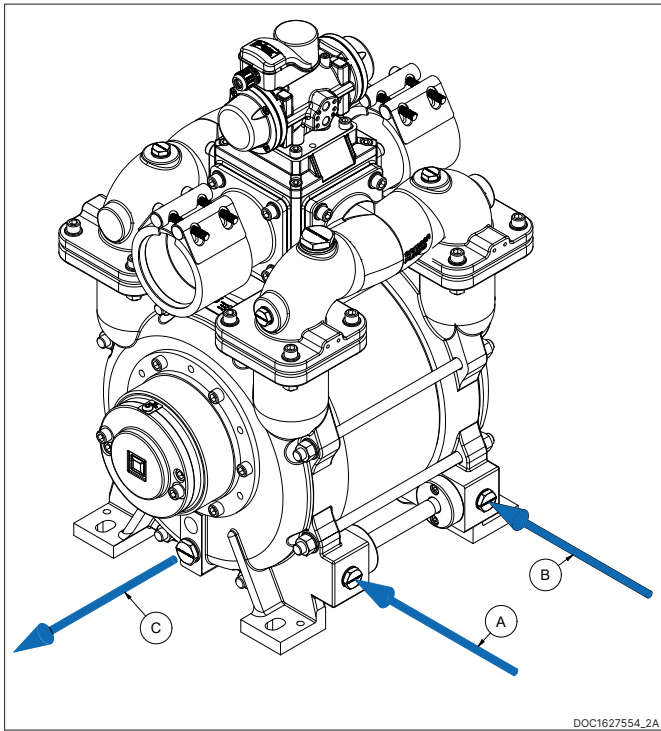

7.2 Connections to the pump



- Check for foreign objects in the pump and physical damage on pump
- Gaskets to be handled with highest degree of caution
- Gasket and sealing surfaces must be cleaned before assembly

In order to prevent tensions in the pump or 4way valve, the pipe connections (A) must be tensionless. Its recommended always to use couplings with a compensating function.

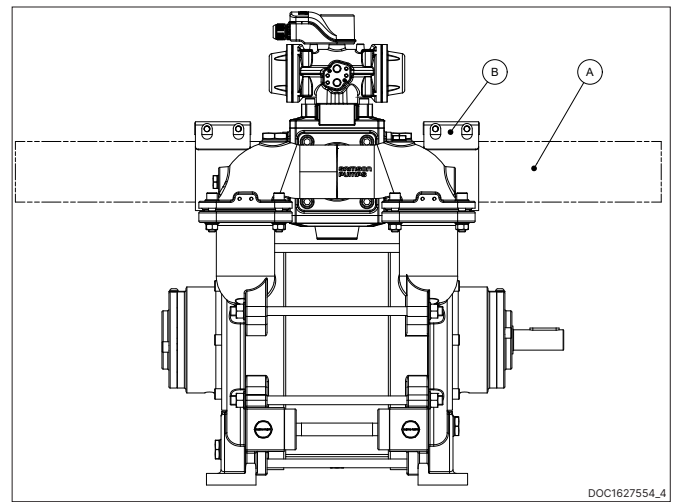

7 Installation & start-up

7.1 Securing the pump



Installation requirements must be observed, otherwise there is a risk of damage

The pump must be installed on a stable foundation, which must be level and stable, so that the pump is not twisted or exposed to a profile distortion.

The pump must be installed with M16 bolts on all four legs, which must be tightened to 180 Nm (A).

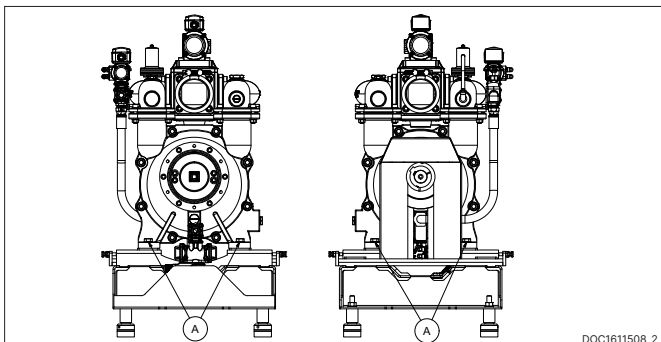

7.3 Connecting the service liquid

The service liquid must be connected to the pump at the hose connection, see illustration.

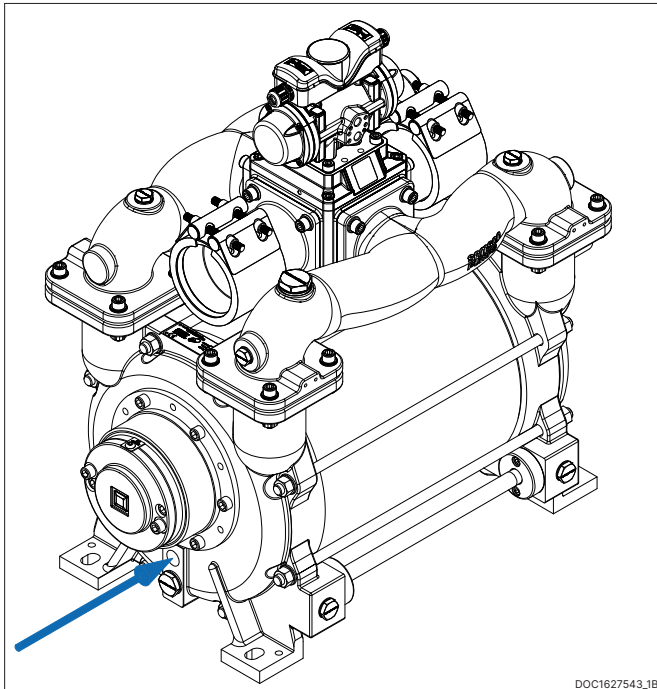

7.4 Drive

The pump can be connected through direct or belt drive. The unit (pump & motor) must be installed on a stable foundation, which must be level and stable, so that the unit is not twisted or exposed to a profile distortion. Misalignemnt tolerances must be complied. See illustration to the right for misalignment types.

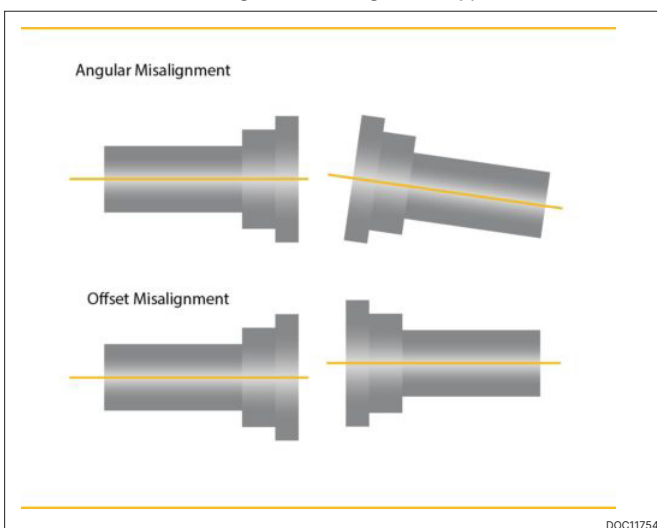

7.5 Direct drive

Angular misalignment : 0,08 mm / 100 mm
 Offset misalignment : 0,1 mm

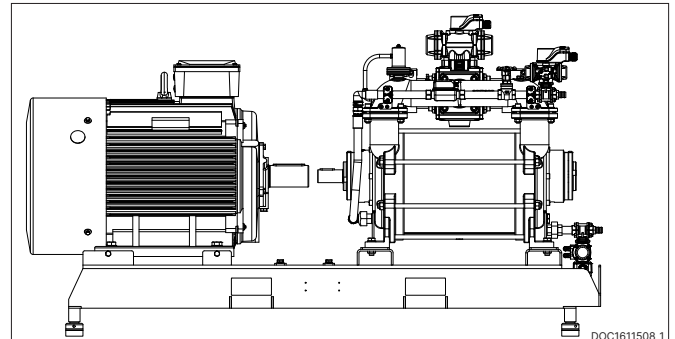

7.6 Belt drive

For belt drive, it must be ensured that the permissible radial force is not exceeded. See specifications.

Angular misalignment : 0,87 mm / 100 mm
 Offset misalignment : 0,1 mm

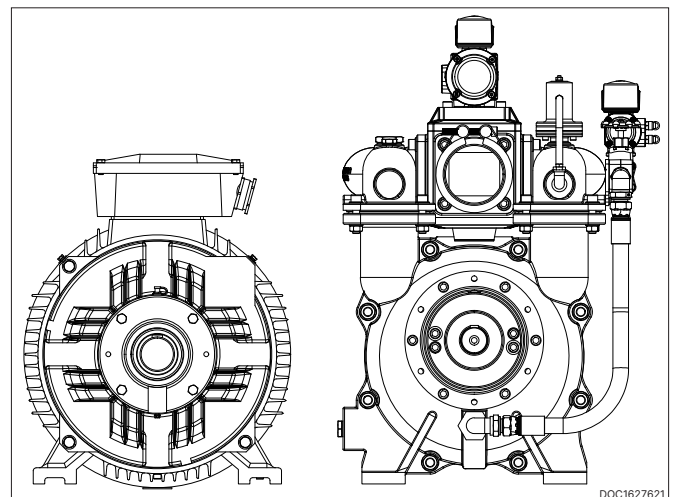

7.7 Prior to start-up



- Do not start the pump without service liquid, as this will damage the mechanical shaft seals
- Do not start the pump if it is completely filled with service liquid
- Do not start the pump before the grease cartridges have been activated, as this can damage the pump (if equipped)
- Stop the pump immediately if the rotational direction does not correspond to the directional arrow
- A failure to follow the above guidelines may result in damage to the pump

Activating the grease cartridges (Accessories and only belt drive)
 Turn the handle in NDE clockwise to position 12.
 Turn the handle in DE clockwise to position 12.
 The pump has been lubricated from factory and is ready to start.

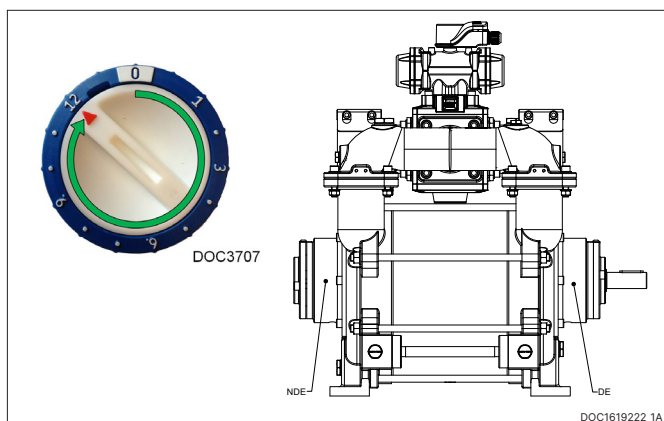

7.8 Direction of rotation

Check the direction of rotation by briefly starting the pump. The direction of rotation of the rotor must correspond to the direction arrow!

Below left, a right-side pump is shown which has a clockwise direction of rotation (CW)

Below, a right-side pump is shown which has a clockwise direction of rotation (CW)

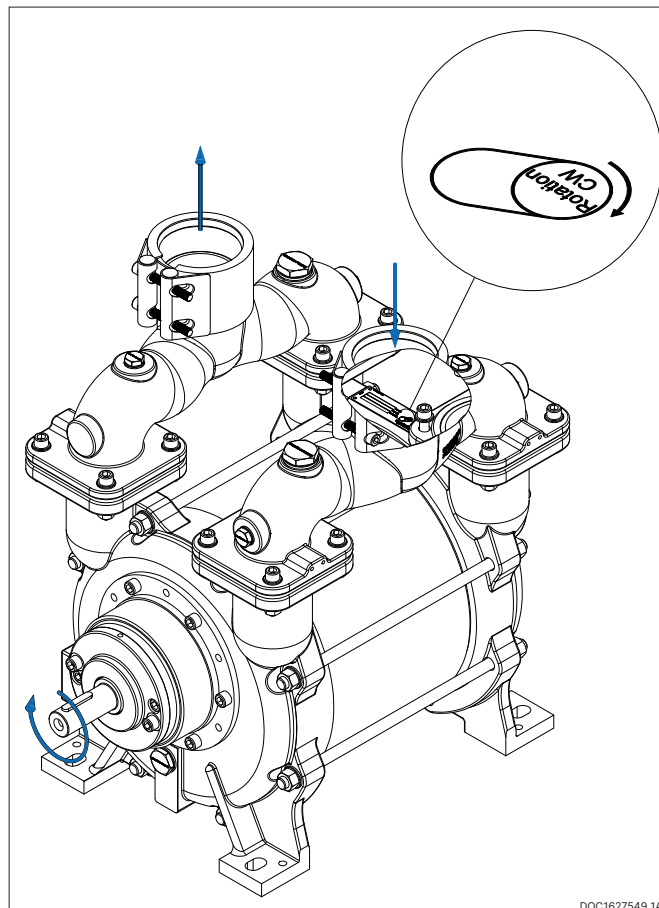

8 Service operation and maintenance and inspection intervals



A failure to observe the inspection intervals described in table below may result in damage to the pump

Section	Operation	Interval
8.1	Check grease cartridges (if equipped) - Only belt drive	Weekly
8.2	Winterization	When below 0°C
8.3	Inspection and cleaning of service liquid's supply pipe	Monthly

8.1 Check grease cartridges - Only belt drive

If the pump is equipped with an automatic lubrication feature. It must be inspected and replaced as needed.

When the pump is commissioned for the first time, the cartridges must be activated by turning the arrow in the clockwise direction. The cartridge is set to 12, which corresponds to an emptying time of 12 months.

The cartridge must be replaced when empty.

It is only allowed to use automatic lubricator of type LAGD 125/WA2.



8.2 Winterization

If the pump needs to be used at a temperature below freezing point of the service liquid, it is necessary to protect the liquid from freezing by adding anti freeze liquid.

8.3 Inspection and cleaning of service liquid supply pipe

The pipe connection between to the pump must be inspected at least once a month, and any contaminants must be removed.

9 Troubleshooting

Problem	Cause	Effect	Corrective measure
The pump is unable to create a vacuum	<ul style="list-style-type: none"> The water valve is closed The pump is not receiving enough service liquid The temperature of the service liquid is too high 	<ul style="list-style-type: none"> Reduced output The pump can become damaged during cavitation 	<ul style="list-style-type: none"> Check the water valve Check the liquid supply Stop the pump and wait until the temperature has dropped to a sufficient level, or lower the temperature of the service liquid inlet
The start-up power is too high	<ul style="list-style-type: none"> Too much service liquid in the pump prior to start-up 	<ul style="list-style-type: none"> Noise at start-up and possible overload of the power supply 	<ul style="list-style-type: none"> Check the stop valves in the liquid supply for leakage
Noise during operation	<ul style="list-style-type: none"> Cavitation Too much water in the pipe system when switching from pressure to vacuum 	<ul style="list-style-type: none"> Severe damage to the pump and potential risk of breakdown 	<ul style="list-style-type: none"> Adjust the service liquid pressure Redesign the pipe system (critical pipe)
Leakage from the bearing housing's drain holes	<ul style="list-style-type: none"> Damaged shaft seal 	<ul style="list-style-type: none"> Bearings may become damaged 	<ul style="list-style-type: none"> Stop the pump and contact the manufacturer
The 4 way valve is not switching position	<ul style="list-style-type: none"> The air pressure is too low 	<ul style="list-style-type: none"> Not possible to switch between suction and discharge 	<ul style="list-style-type: none"> Raise the air pressure
	<ul style="list-style-type: none"> Control signal missing 		<ul style="list-style-type: none"> Check the PLC signal
	<ul style="list-style-type: none"> The flanges are deforming the valve 		<ul style="list-style-type: none"> All flanges connected to the valve must be machined
The 4 way valve is leaking from the valve spindle	<ul style="list-style-type: none"> Defect seals 	<ul style="list-style-type: none"> Bearings may be damaged 	<ul style="list-style-type: none"> Change the sealing

10 Marking & identification

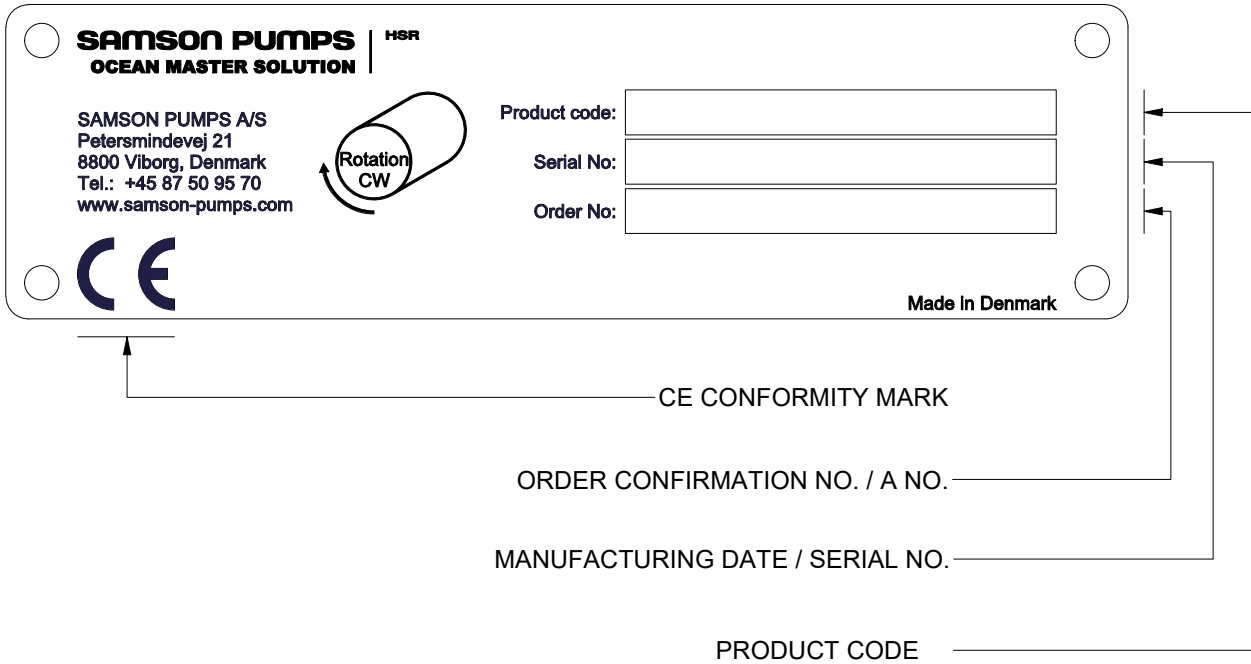

Configuration example:

OMS xxxx E P A1 1 1 W1 0 0 0

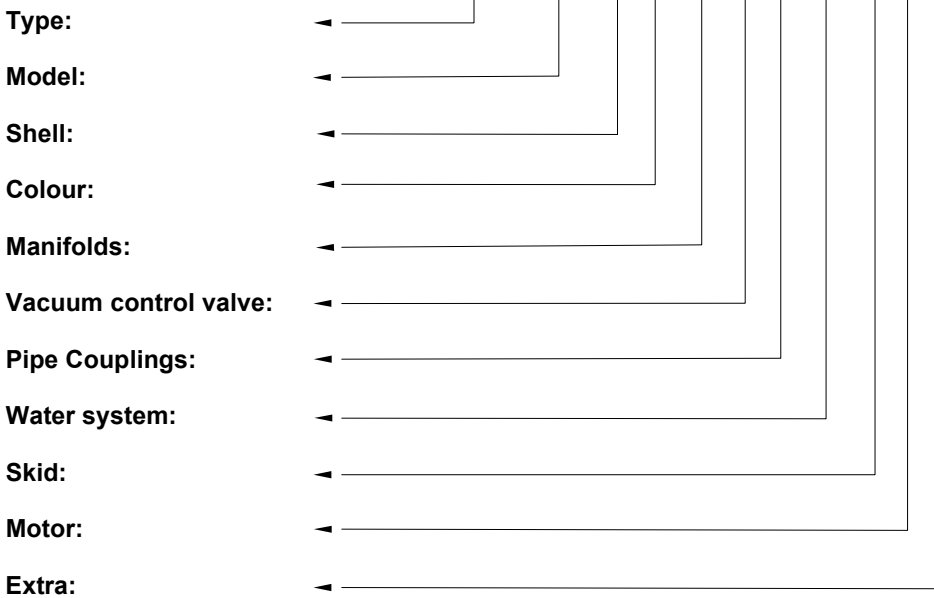

DOC108024