

# Water Separator Series

INSTALLATION  
OPERATION  
MAINTENANCE

ATEX APPLICABLE

A black, cylindrical water separator unit with a hemispherical top and a hemispherical bottom. It has two horizontal ports on the side. The top port is larger and has a label with an arrow pointing left and the text 'Air & Water mix inlet' and 'Connect to pump discharge'. The bottom port is smaller. The unit is shown against a dark blue background.

Air & Water mix inlet  
Connect to pump discharge

**MODELS:**  
Water Separator DN80  
Water Separator DN100

## Table of contents

Page	Chapter	
3	<b>1</b>	<b>Introduction</b>
3	1.1	Declaration of Conformity
4	1.2	Digital services
4	1.3	Explanation of warning symbols
4	1.4	Field of application
4	1.5	Disposal
5	<b>2</b>	<b>Technical data</b>
5	2.1	Specifications
5	2.2	Handling and transport
5	2.3	Storage
6	2.4	Dimensions
7	2.5	Function of connections
8	2.6	Performance
8	2.7	Right sizing
9	<b>3</b>	<b>Design of a system</b>
9	3.1	Mounting
9	3.2	Connection to internal pipe system
10	3.3	Placing on the vehicle
10	3.4	Drain procedures for water separator
10	<b>4</b>	<b>Installation and start-up</b>
10	4.1	Installation
10	<b>5</b>	<b>Service operation and maintenance and inspection intervals</b>
10	5.1	Winterization
10	5.2	Drain inspection
10	5.3	Visually Inspecting for leakage
10	<b>6</b>	<b>Spare parts and tools</b>
11	<b>7</b>	<b>Troubleshooting</b>

# 1 Introduction

## 1.1 Declaration of Conformity



### Declaration of incorporation

Annex IIB

Samson Pumps A/S  
Petersmindevej 21  
DK-8800 Viborg

Hereby declares that the following products:

**Water Separator DN80 & DN100**  
**Water Separator 5, -10, -20, -30, -40, -50, -60, -70, -90, -100**

Conforms to the directive:

**Machinery Directive 2006/42/EC**

I hereby declare that the liquid ring pumps are in conformity with the following harmonized standards:

DS/EN ISO 12100:2011	Safety of machinery - General principles for design - Risk assessment and risk reduction
DS/EN 1012-2 + A1:2009	Compressors and Pumps - Safety requirements - Part 2: Vacuum pumps

The standards above only apply to the extent that it is relevant for the purpose of the Water Separator. The product must not be used before the complete system, which it must be incorporated in, has been conformity assessed and found to comply with all relevant health and safety requirements of 2006/42/EC and other relevant directives. The product must be included in the overall risk assessment.

The equipment must not be exposed to an operating pressure of more than 0.5 bar gauge.

Viborg, 30.04.2024

  
Jan S. Christiansen – Manager, Technical dept.

## 1.2 Digital services

Samson Pumps offers a number of digital services to help our customers gain the best possible output from our products.

### Calculate



Solution Finder

### Buy



Product Center

### Learn



How to build

## 1.3 Explanation of warning symbols

Important technical and safety instructions are shown by symbols. If the instructions are not performed correctly, it can lead to personnel injuries or incorrect function of the water separator.



To be used with all safety instructions that must be followed. A failure to follow the instructions may result in injuries and/or incorrect machine operation

## 1.4 Field of application



- Inlet of foreign objects can damage the Water Separator
- The Water Separator is designed exclusively to separator outlet gases from liquid ring vacuum pumps
- Comply to general specifications in chapter Technical data

The water separator is designed to separate water and air, from a liquid ring vacuum pump exhaust. This separation will not be 100%, but only partially. A minor part of the liquid exhaust will evaporate into the atmosphere and drops of liquid from the exhaust will occur as well.

The water separator must be placed in a safe position on the vehicle, without risk of collision with branches, wires or other objects that may come in its way.

## 1.5 Disposal

Samson's water separator is manufactured so that the whole device can be reused/recycled. Samson Pumps offer all users the option of returning used products to be restored or scrapped.

Alternatively, the water separator must be taken apart and sorted into its separate components, by the customer (see chapter "Specifications").

These components must be disposed of in accordance with national regulations.

## 2 Technical data

### 2.1 Specifications



A failure to meet these specifications may result in damage to the water separator

General specifications	Water Separator DN80	Water Separator DN100
Ambient temperature, storage MAX	55°C	55°C
Ambient temperature, storage MIN	-20°C	-20°C
Inlet temperature Air & water mix, MAX	85°C	85°C
Weight	22 kg	25 kg
Volume	36 L	61 L
Pressure MAX	0,5 bar(g)	0,5 bar(g)
Test pressure	1 bar(g)	1 bar(g)
Molded parts	Cross-linked PE	Cross-linked PE
Steel parts	AISI316L	AISI316L
Seals	NBR	NBR







### 2.2 Handling and transport

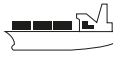

A failure to meet these specifications may result in damage to the water separator

The water separator must be transported in such way that it is not exposed to stroke or other shock impacts that might damage product.

The water separator must be inspected for damages upon delivery. If the water separator is damaged, it must not be used, and the damage must be reported to the manufacturer.

Handling & transport	
Road	 
Sea	 
Air	 

DOC11093A

### 2.3 Storage

The water separator can be stored without any further actions.

2.4 Dimensions

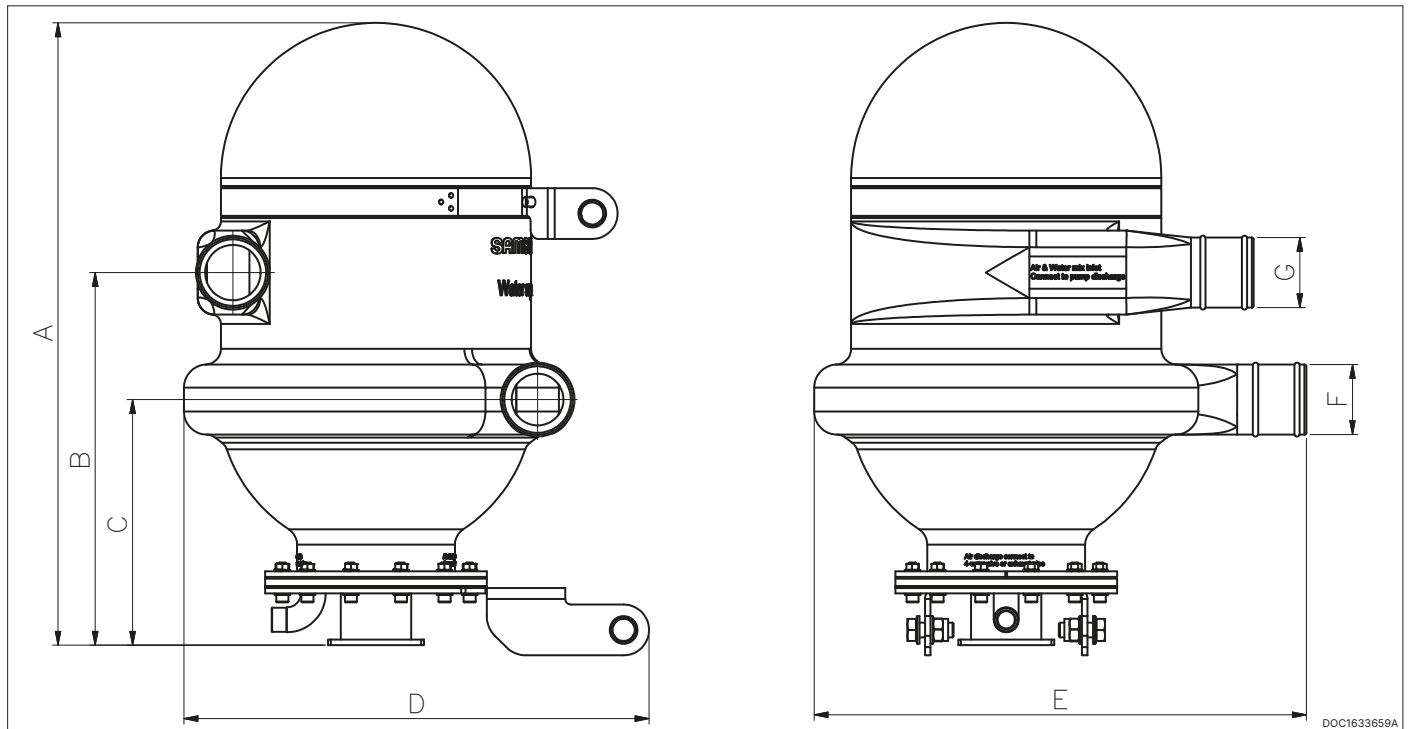

DOC1633659A

Model	A	B	C	D	E	F	G
Water Separator DN80	674mm / 26,5 in	404mm / 15,9 in	266mm / 10,5 in	504mm / 19,8 in	533mm / 21,0 in	Ø76mm / 3,1 in	Ø76mm / 3,1 in
Water Separator DN100	759mm / 29,9 in	448mm / 17,6 in	292mm / 11,5 in	552mm / 21,7 in	558mm / 22,0 in	Ø76mm / 3,1 in	Ø102mm / 4,1 in

## 2.5 Function of connections

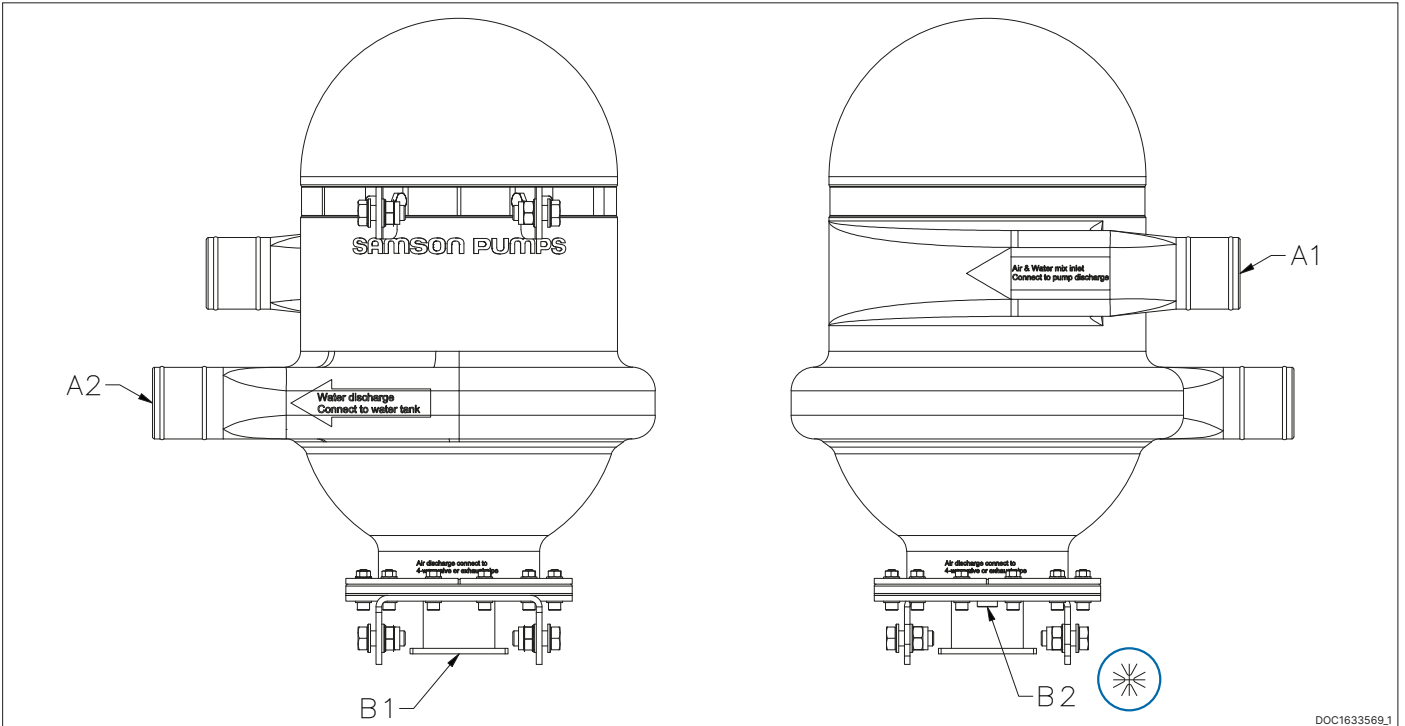

DOC1633569\_1

ID	Name	Function & how to connect	Water Separator DN80	Water Separator DN100
A1	Air & water mix inlet	Connect A1 to the discharge side of the pump.	3"	3"
A2	Water discharge	A2 will return the separated water and must be connected to water tank.	3"	4"
B1	Air discharge	B1 will return the separated air and must be connected to the 4way valve, or final exhaust piping.	DN80	DN100
B2	Drain 	B2 is a winterization drain hole, designed to drain away water-remains by gravity, after the vehicle stops operating. B2 can be connected to the pressure side of the liquid ring vacuum pump, or to the water tank where it will drain in between operations, automatically.	G1/2"	G1/2"



B1 connected to a 4way valve.  
In discharge position, the 4way valve will enable emptying of the vehicle slurry tank by connecting the pump discharge side.

## 2.6 Performance

The water separator is designed to separate water and air, from a liquid ring vacuum pump exhaust. This separation will not be 100%, but only partially. A minor part of the liquid exhaust will evaporate into the atmosphere and drops of liquid from the exhaust will occur as well.

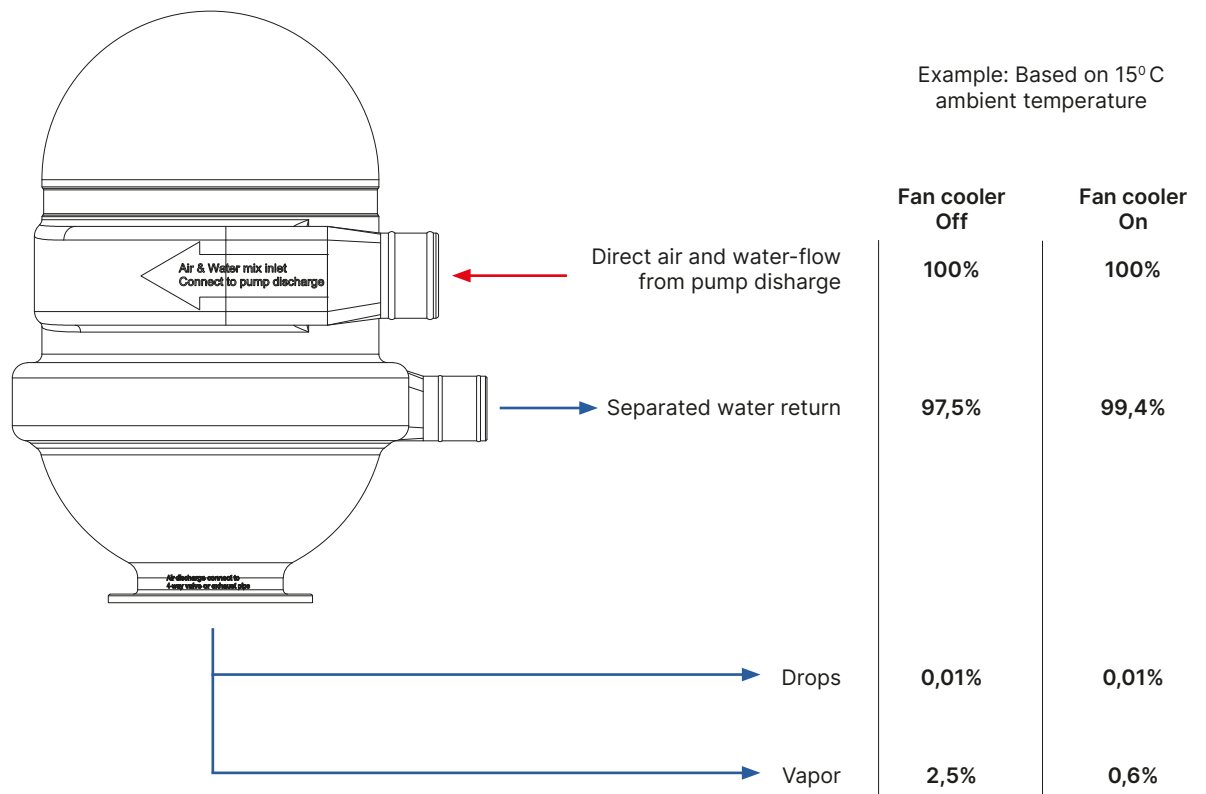

## 2.7 Right sizing

Vehicle suction hose	Recommended vacuum pump	4way valve	Recommended water separator
	Suction hose 2"	Truck Master 2	Water Separator DN80
	Suction hose 3"	Truck Master 3	
	Suction hose 4"	Truck Master 1700	4way valve DN100
	Suction hose 5"	Truck Master 2500	
	Suction hose 6"	Truck Master 3400	4 way valve DN125



### 3 Design of a system

#### 3.1 Mounting



A failure to meet these specifications may result in damage to the water separator

The water separator must be placed in a safe position on the vehicle, without risk of collision with branches, wires or other objects that may come in its way.

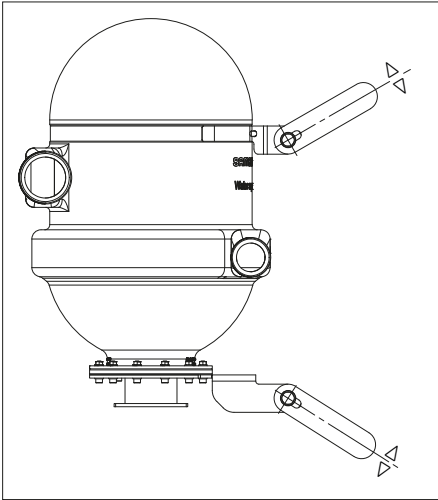

A: All four fittings are adjustable in individual angles.

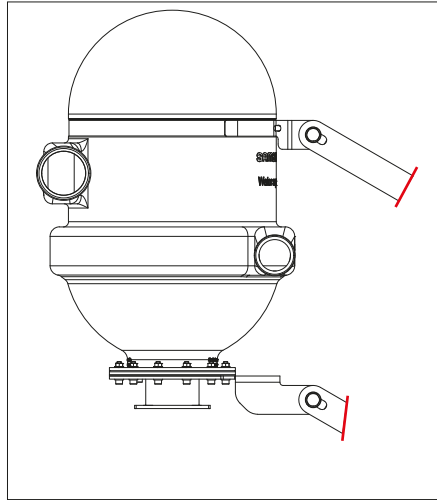

B: Modification to the specific project.

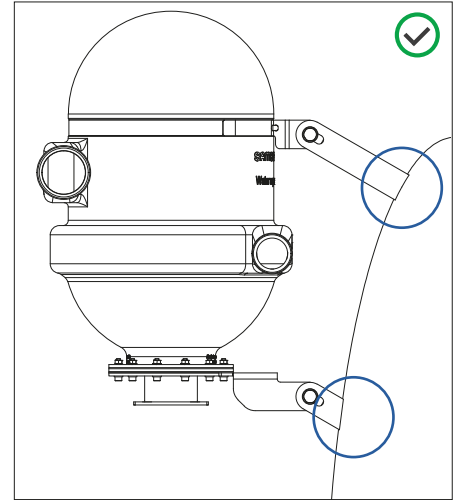

C: Ensure a safe mounting by welding the four fittings to the main structure of the vehicle.

#### 3.2 Connection to internal pipe system



A failure to meet these specifications may result in damage to the water separator

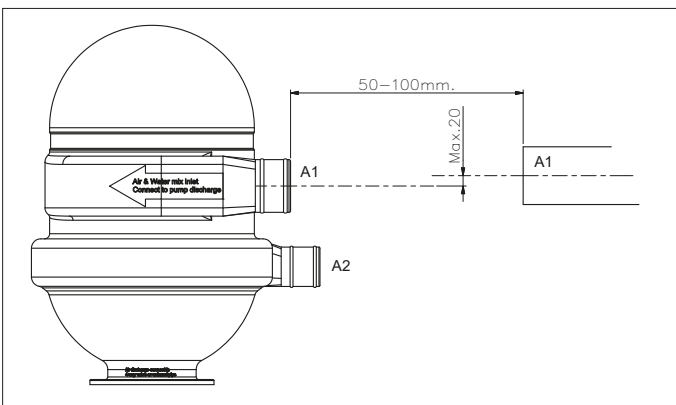

Its important that connection A1 and A2 is connected to a solid steel pipe.

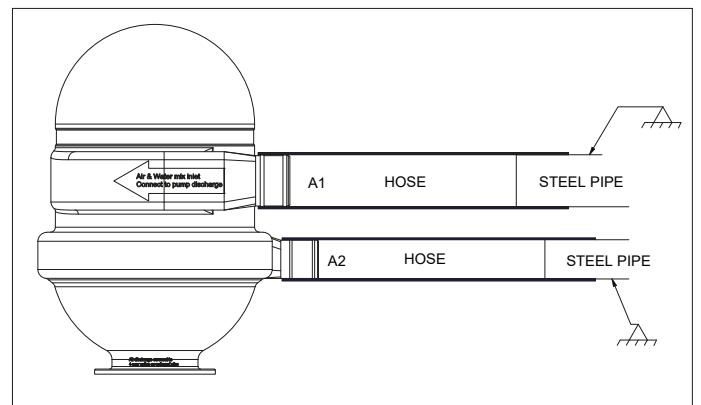

Connect A1 and A2 to the steel pipes by using a plastic hose sleeve.

### 3.3 Placing on the vehicle

The water separator must be placed in a safe position on the vehicle, without risk of collision with branches, wires or other objects that may come in its way.

It's also important to ensure a certain height to water separator: Please see illustration below:

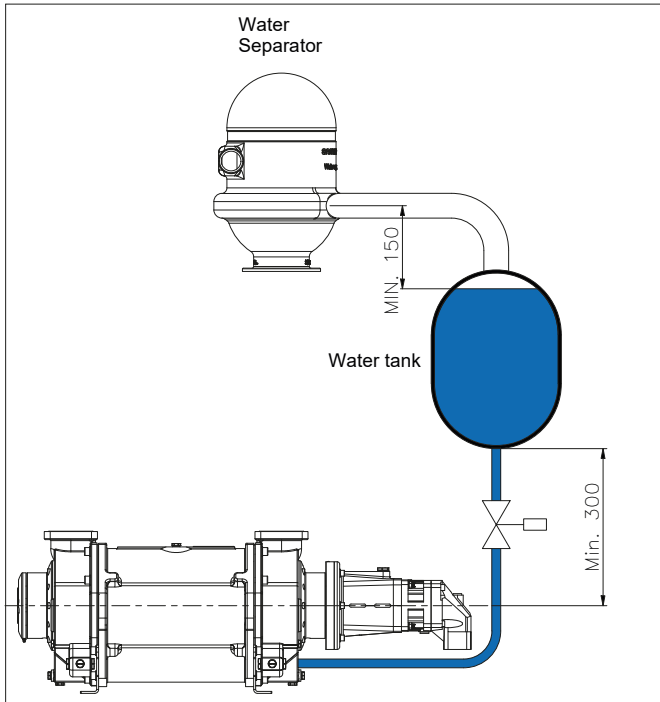

### 3.4 Drain procedures for water separator

The water separator must be drained from connection B2 to prevent accumulation of ice, and as a result of that, reduced performance.

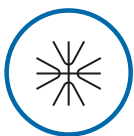

## 4 Installation and start-up

### 4.1 Installation



Installation requirements must be observed, otherwise there is a risk of damage

The water separator must be installed in such a way that is not twisted or exposed to a profile distortion. All connections must be tensionless.

Check that all connections are free and not clogged in any way.

## 5 Service operation and maintenance and inspection intervals



• Check for foreign objects in the water separator

Section	Operation	Frequency
5.1	Winterization when below 0°C	When below 0°C
5.2	Inspection of 1/2" drain from water separator	Weekly
5.3	Visually inspect for leakage	Weekly

### 5.1 Winterization

If the water separator needs to be used at a temperature below freezing point of the water, it is necessary to protect the water from freezing by adding anti freeze liquid.

### 5.2 Drain inspection

It is necessary to inspect the 1/2" drain from water separator to ensure that it is not clogged.

### 5.3 Visually Inspecting for leakage

The water separator and pipe system around the water separator must be inspected for leakage once a week. The inspection must be performed when the system is operating at idle. Any leaks must be repaired before operation may continue.

## 6 Spare parts and tools

To order spare parts, please visit the Samson Pumps Product center.

Buy



Product Center

## 7 Troubleshooting

Problem	Cause	Effect	Corrective measure
Water is coming out of the air discharge connection	<ul style="list-style-type: none"><li>• Water level in tank is too high</li><li>• The connections are incorrect</li></ul>	<ul style="list-style-type: none"><li>• Poor water separation</li></ul>	<ul style="list-style-type: none"><li>• Check water level in tank</li><li>• Check connections</li></ul>